



C65

C64



LA
AURORA
LOGÍSTICA

LOGO

AURORA

Tu centro de distribución
en ZONA 13



Diseño e imágenes con fines ilustrativos; nos reservamos a cambios sin previo aviso



COMBEX-IM



AEROPUERTO
LA AURORA



TALLER
CANELLA



COLONIA
SANTA FE



28 CALLE

AVENIDA HINCAPIE

10a AVENIDA

LA
AURORA
LOGÍSTICA

UBICACIÓN

LOGÍSTICA LA AURORA

9na avenida 28-32 Colonia Santa Fe.

Zona 13.

SERVICIOS

INFRAESTRUCTURA

- Control de acceso
- Garita de seguridad
- Circuito de cámaras
- Servicios básicos

ACCESIBILIDAD

- Vías de circulación amplias para transporte pesado

DISEÑO

- Los mejores estándares de calidad estructural y eficiencia logística





EDIFICIO



LA AURORA
LOGÍSTICA

EL ESPACIO QUE SE ADAPTA
a tu giro de negocio

Diseño e imágenes con fines ilustrativos; nos reservamos a cambios sin previo aviso

EDIFICIO

PLANTA TÍPICA

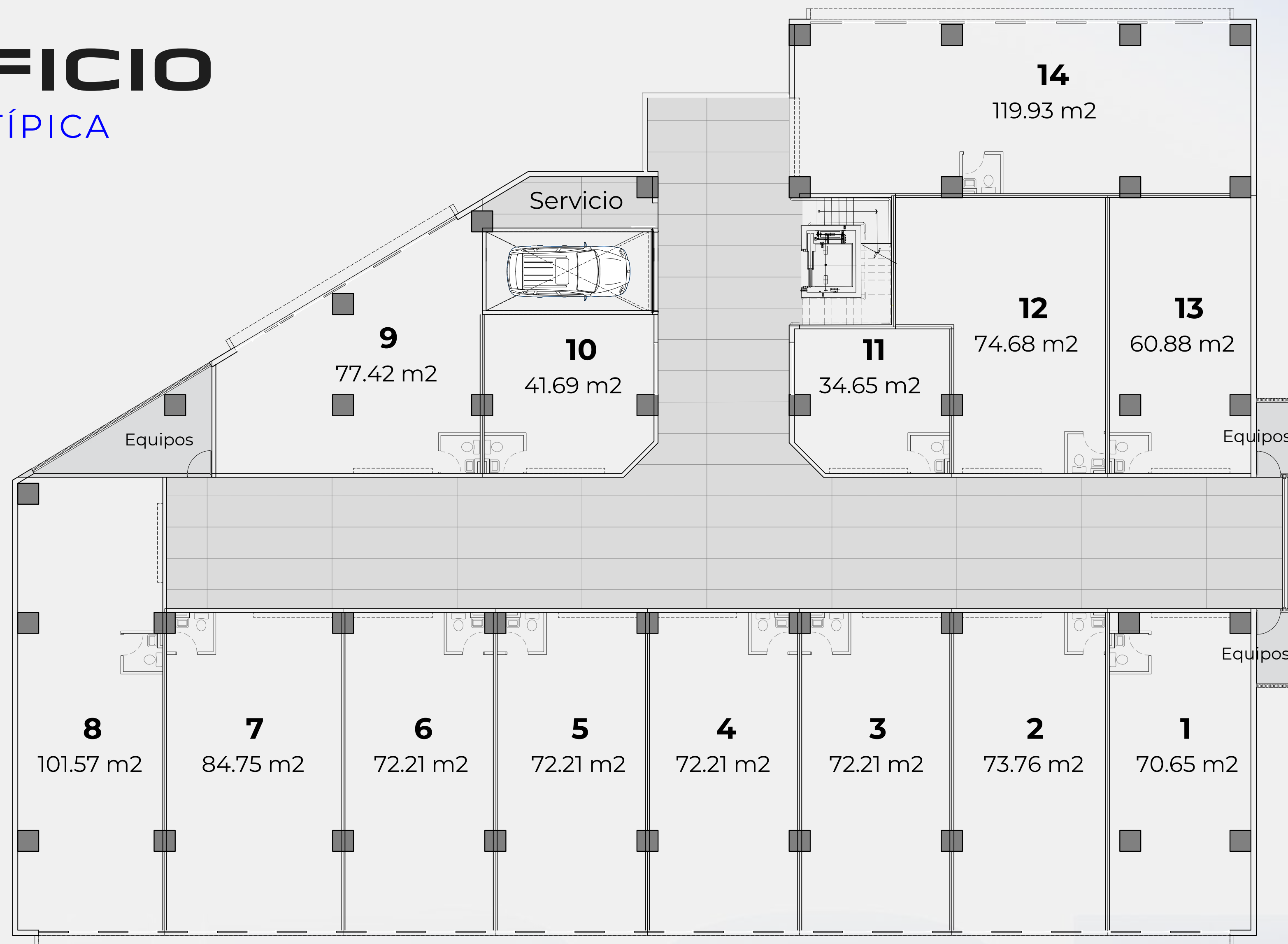



Diseño e imágenes con fines ilustrativos; nos reservamos a cambios sin previo aviso



Diseño e imágenes con fines ilustrativos; nos reservamos a cambios sin previo aviso

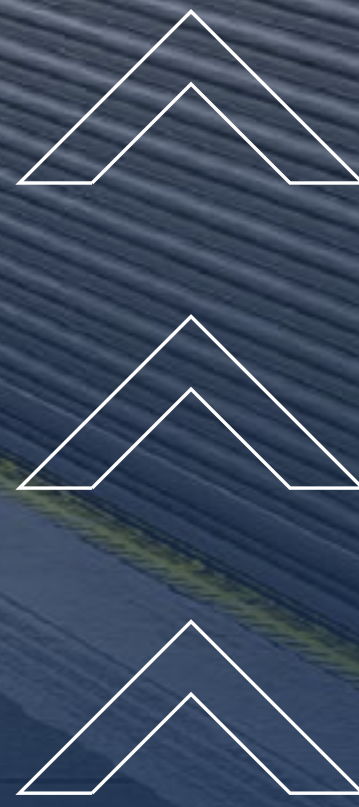



Escribe tu
PROPIA HISTORIA DE ÉXITO

Diseño e imágenes con fines ilustrativos; nos reservamos a cambios sin previo aviso



PLANTA

DEL CONJUNTO

MODELO T1

C53-C66

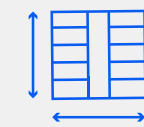

10*24.50 mts²

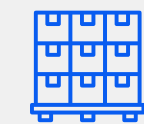

205.95 mts² de bodega



119.16 mts² de oficina



325.11 mts² de construcción



3,000 kg/mt² capacidad de soporte



3 baños



4 parqueos



Con Andén

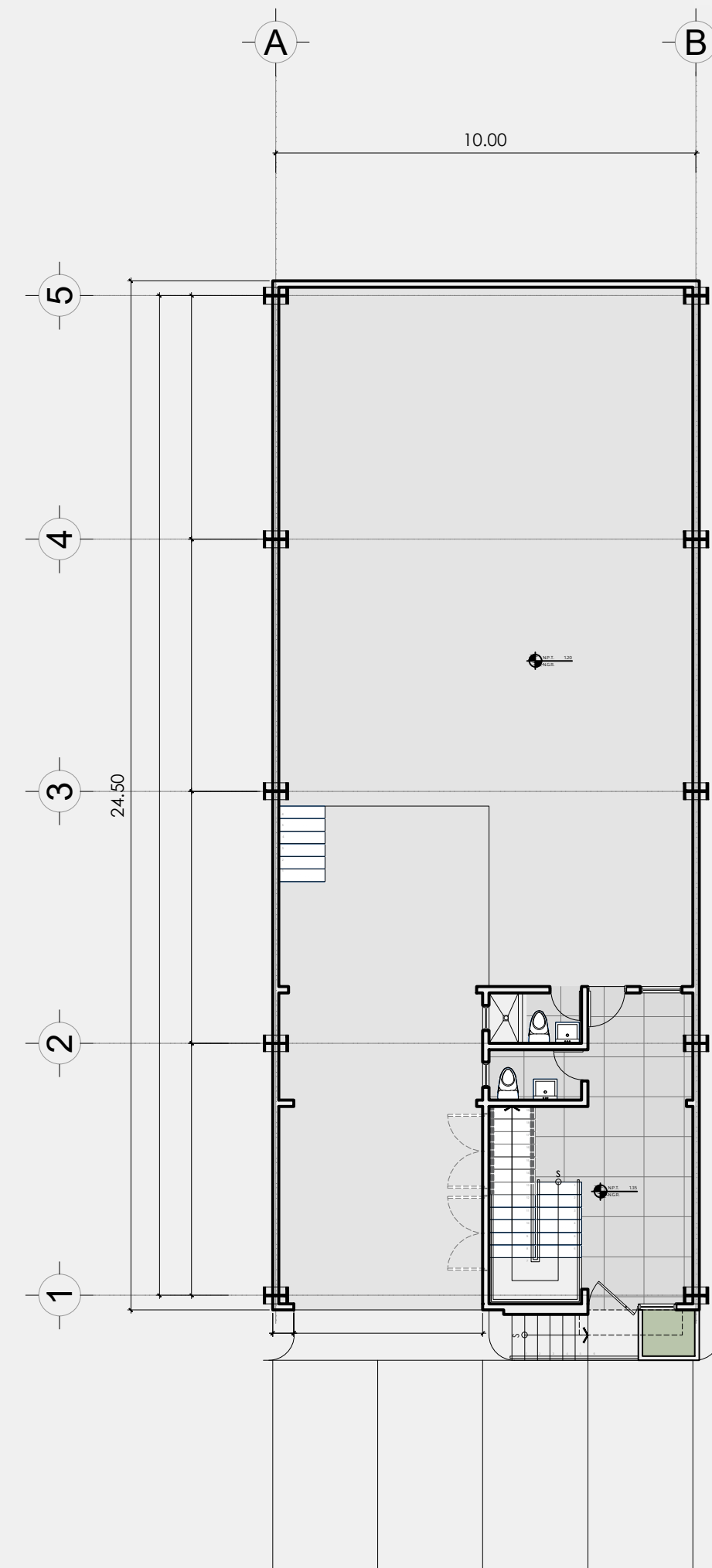

PLANTA PRIMER NIVEL

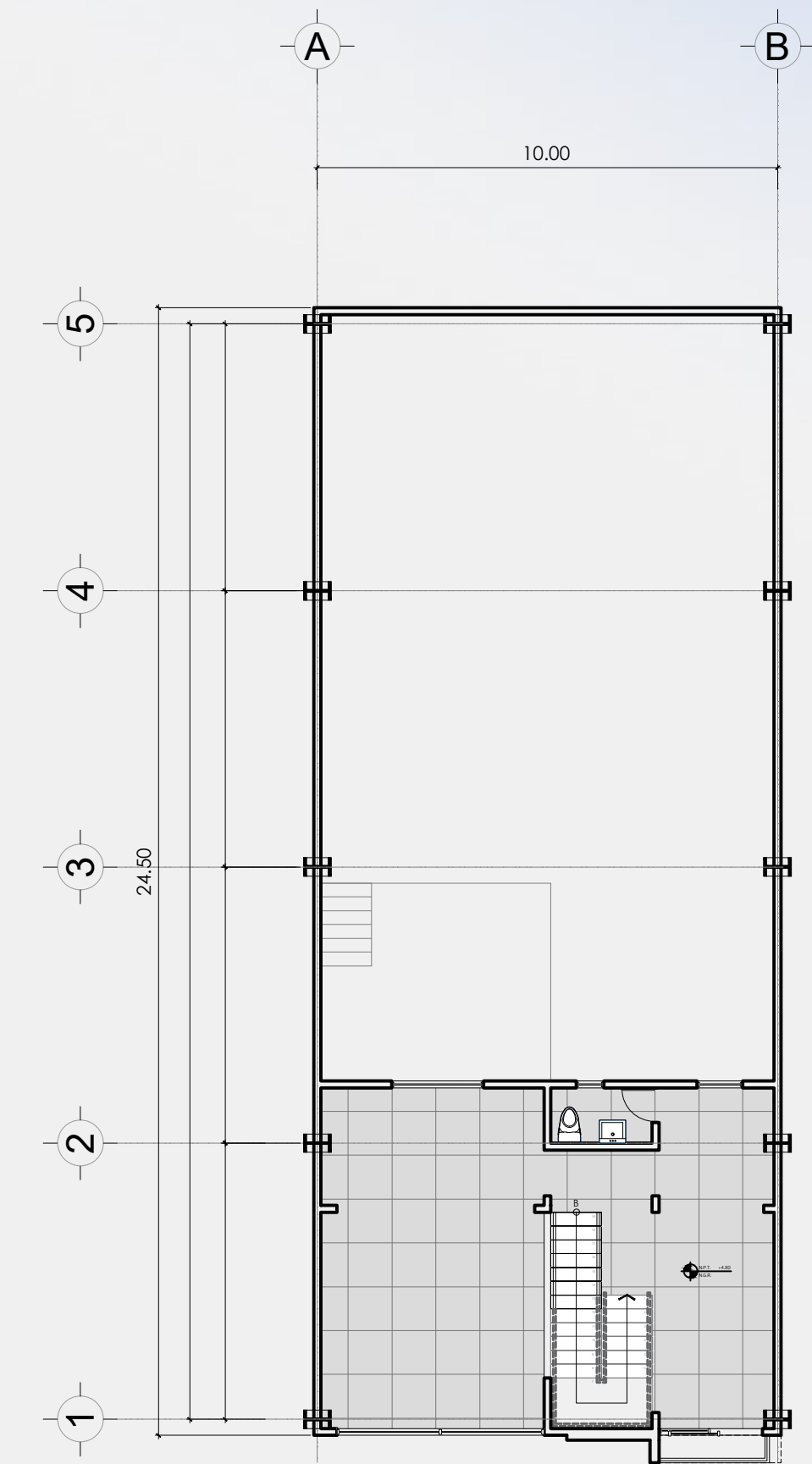

PLANTA MEZZANINE



MODELO T1
C53-C66

Diseño e imágenes con fines ilustrativos; nos reservamos a cambios sin previo aviso

MODELO T2

A77-A87

B1-B8

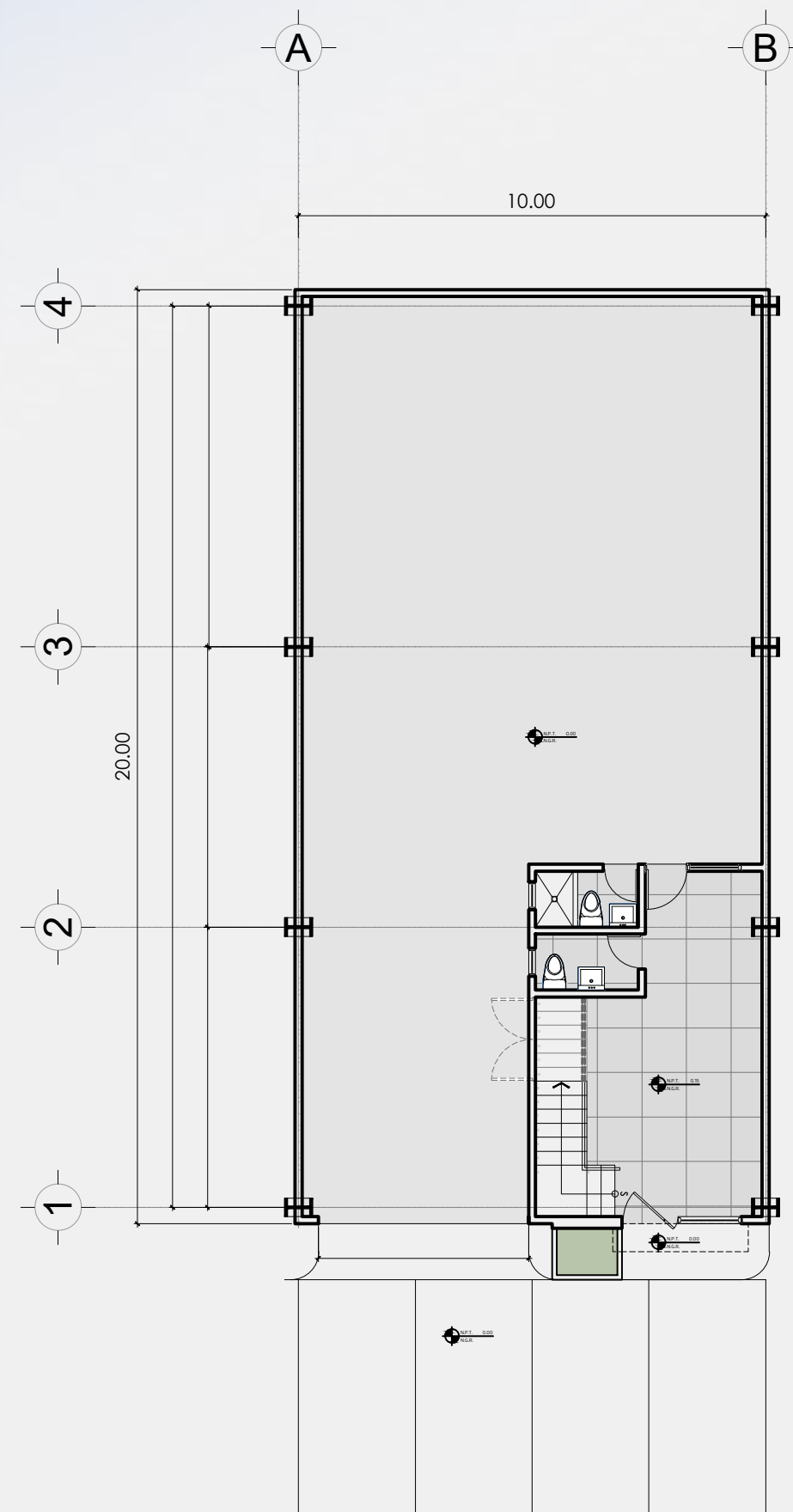

PLANTA PRIMER NIVEL

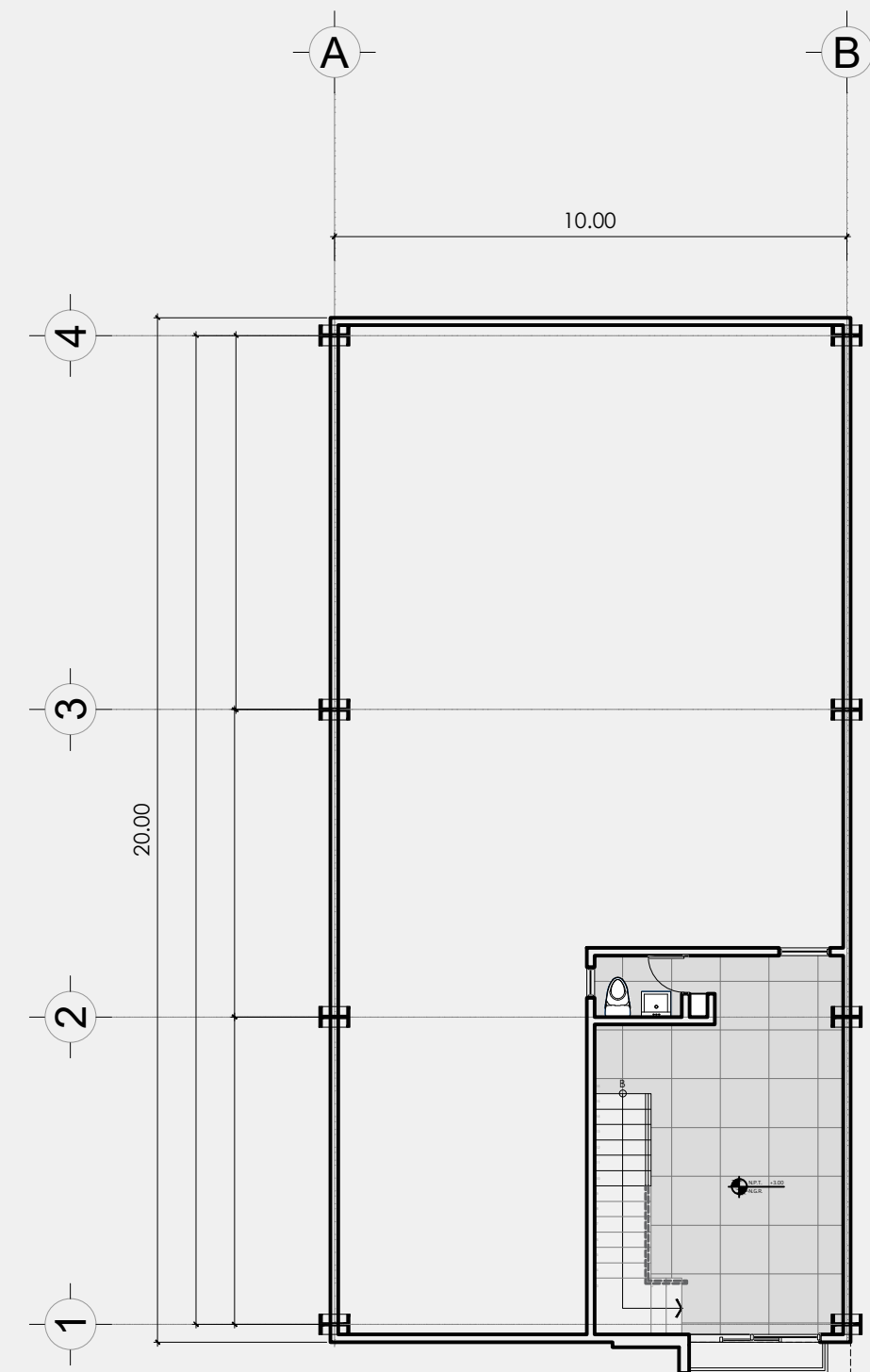

PLANTA MEZZANINE

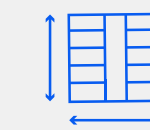

10*20 mts²

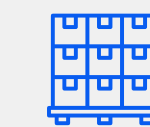

160.92 mts² de bodega



81.82 mts² de oficina



242.74 mts² de construcción



3,000 kg/mt² capacidad de soporte



3 baños



4 parqueos



Sin Andén

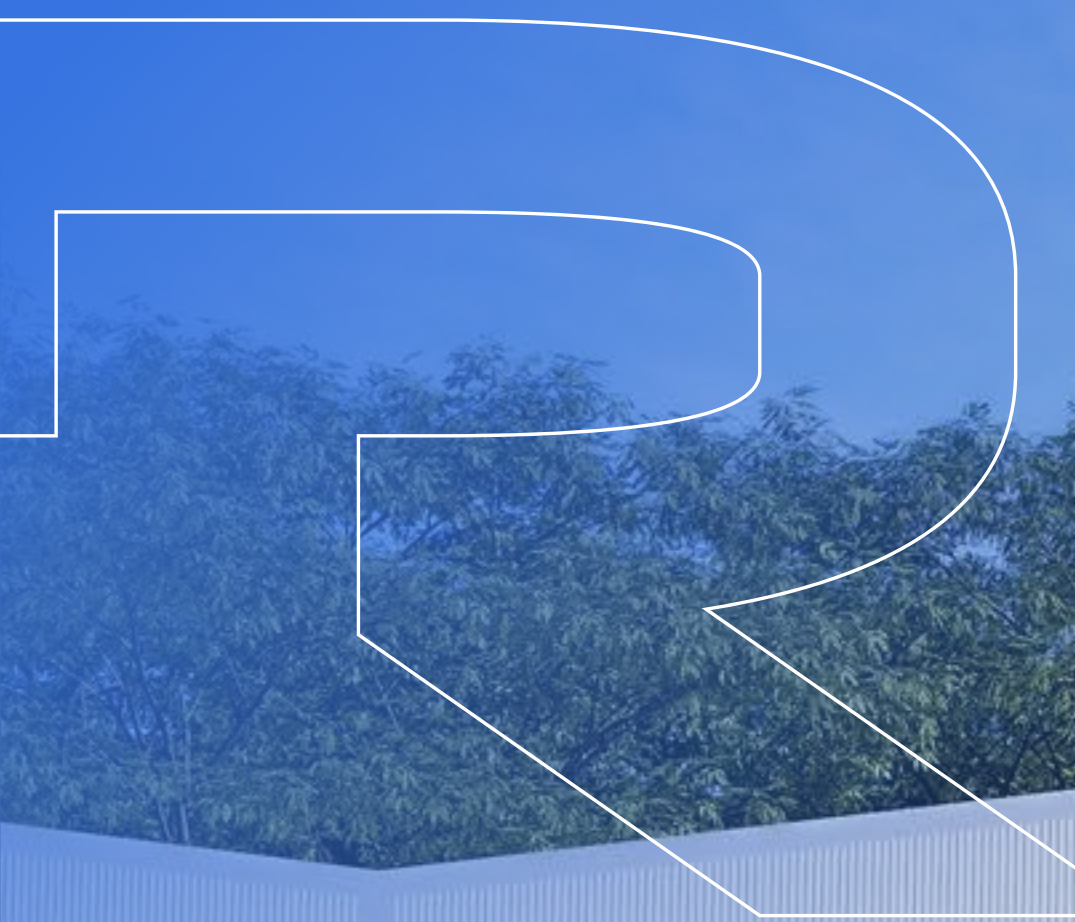

MODELO T2
A77-A87, B1-B8

Diseño e imágenes con fines ilustrativos; nos reservamos a cambios sin previo aviso

MODELO T3

C43-C52

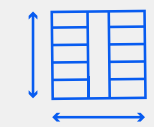

15*48 mts²

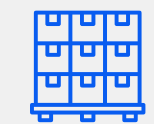

626.31 mts² de bodega



239.30 mts² de oficina



865.61 mts² de construcción



2000 kg/mt² capacidad de soporte



3 baños



6 parqueos



Con Andén

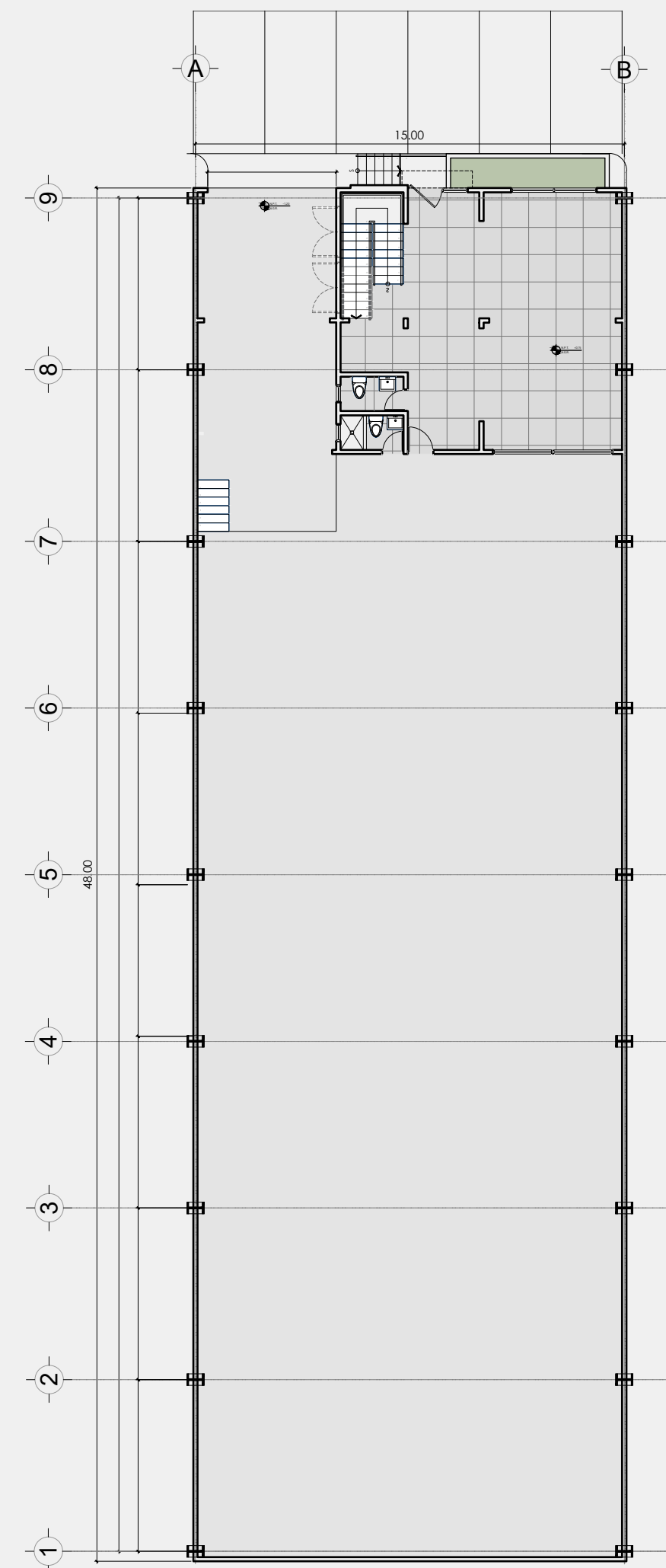

PLANTA PRIMER NIVEL

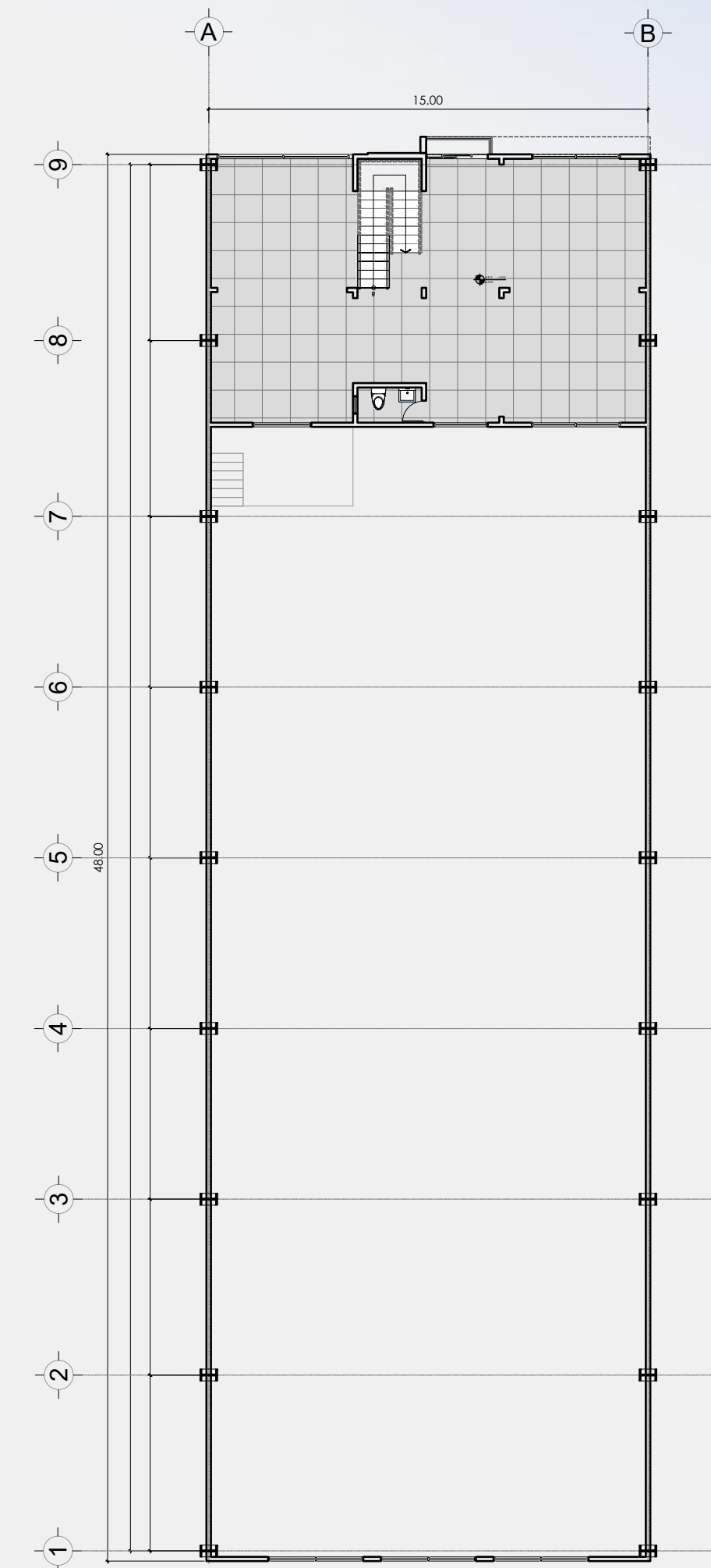

PLANTA MEZZANINE



MODELO T3
C43-C52

Diseño e imágenes con fines ilustrativos; nos reservamos a cambios sin previo aviso



MODELO T3
C43-C52

Diseño e imágenes con fines ilustrativos; nos reservamos a cambios sin previo aviso

MODELO T4

C33-C42

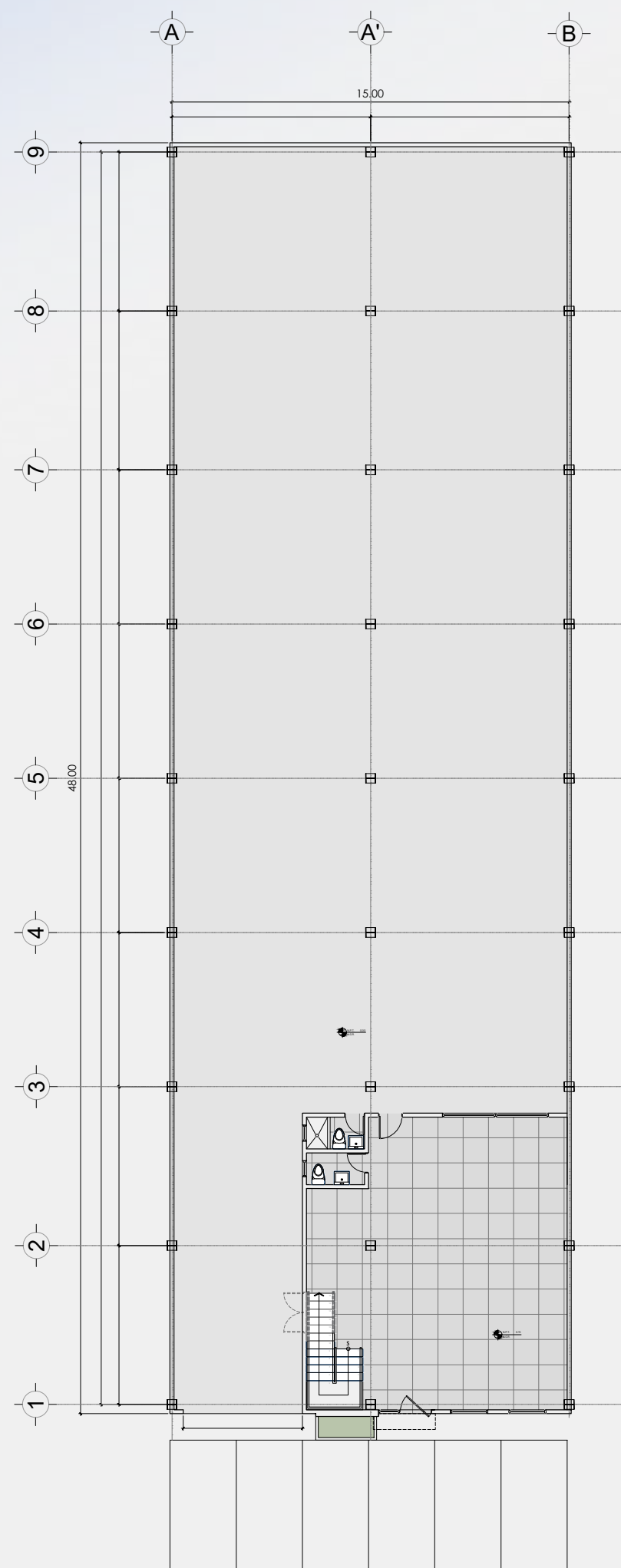

PLANTA PRIMER NIVEL

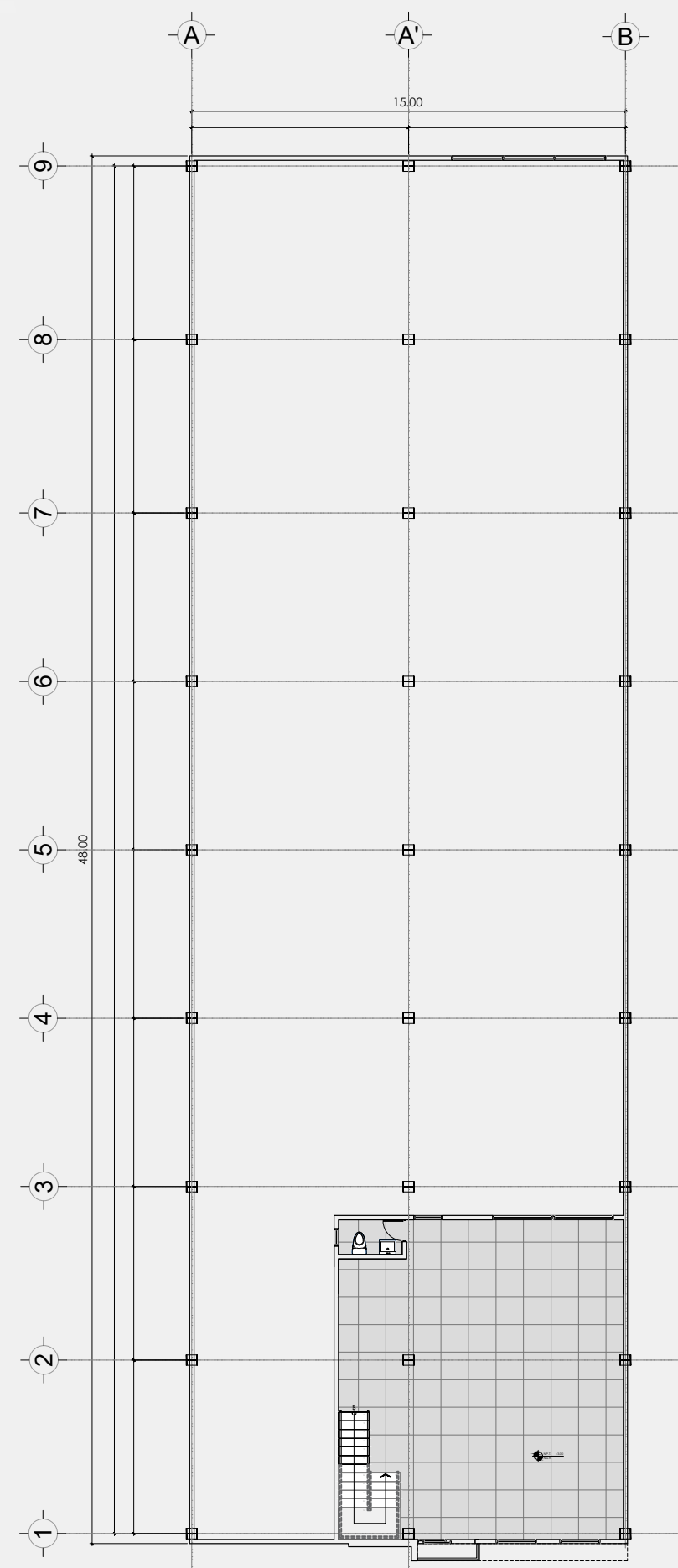

PLANTA MEZZANINE

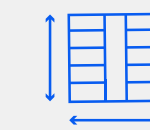

15*48 mts²

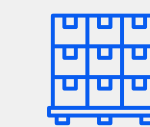

605.65 mts² de bodega



234.56 mts² de oficina



840.21 mts² de construcción



3,000 kg/mt² capacidad de soporte



3 baños



6 parqueos



Sin Andén

(*Bodegas Planta Baja)

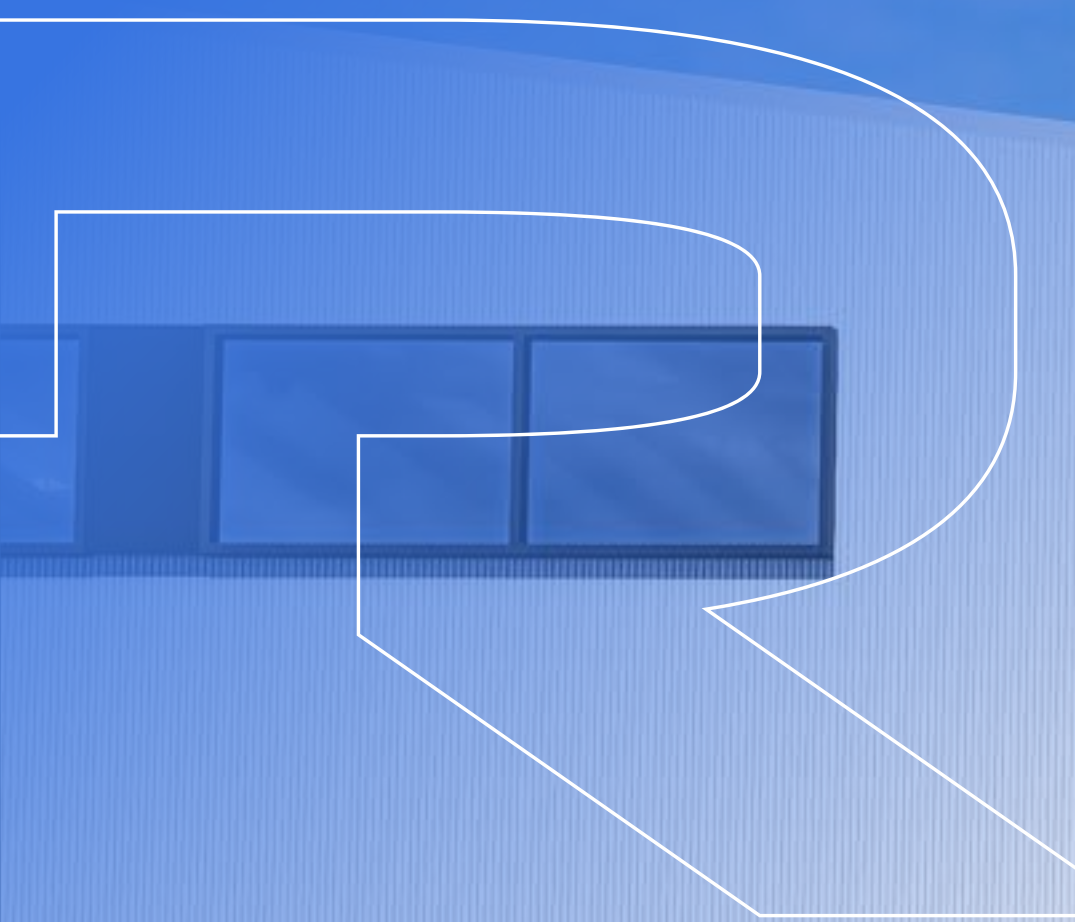

C40

MODELO T4
C33-C42

Diseño e imágenes con fines ilustrativos; nos reservamos a cambios sin previo aviso



MODELO T4
C33-C42

Diseño e imágenes con fines ilustrativos; nos reservamos a cambios sin previo aviso

MODELO T5

D26-D32

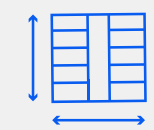

15*37 mts²

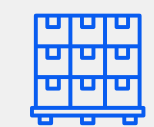

467.85 mts² de bodega



223 mts² de oficina



690.85 mts² de construcción



2,000 kg/mt² capacidad de soporte



3 baños



6 parqueos



Con Andén

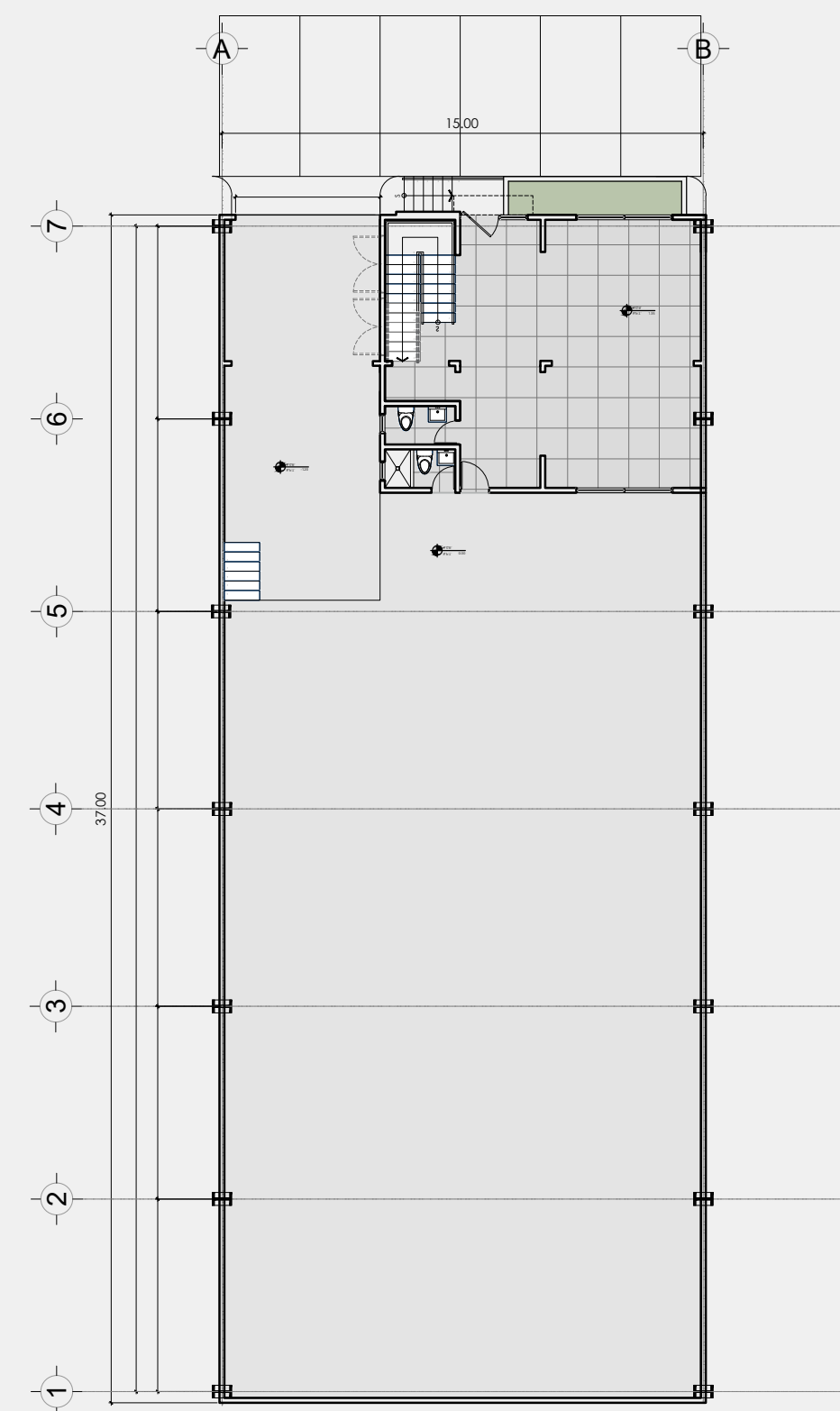

PLANTA PRIMER NIVEL

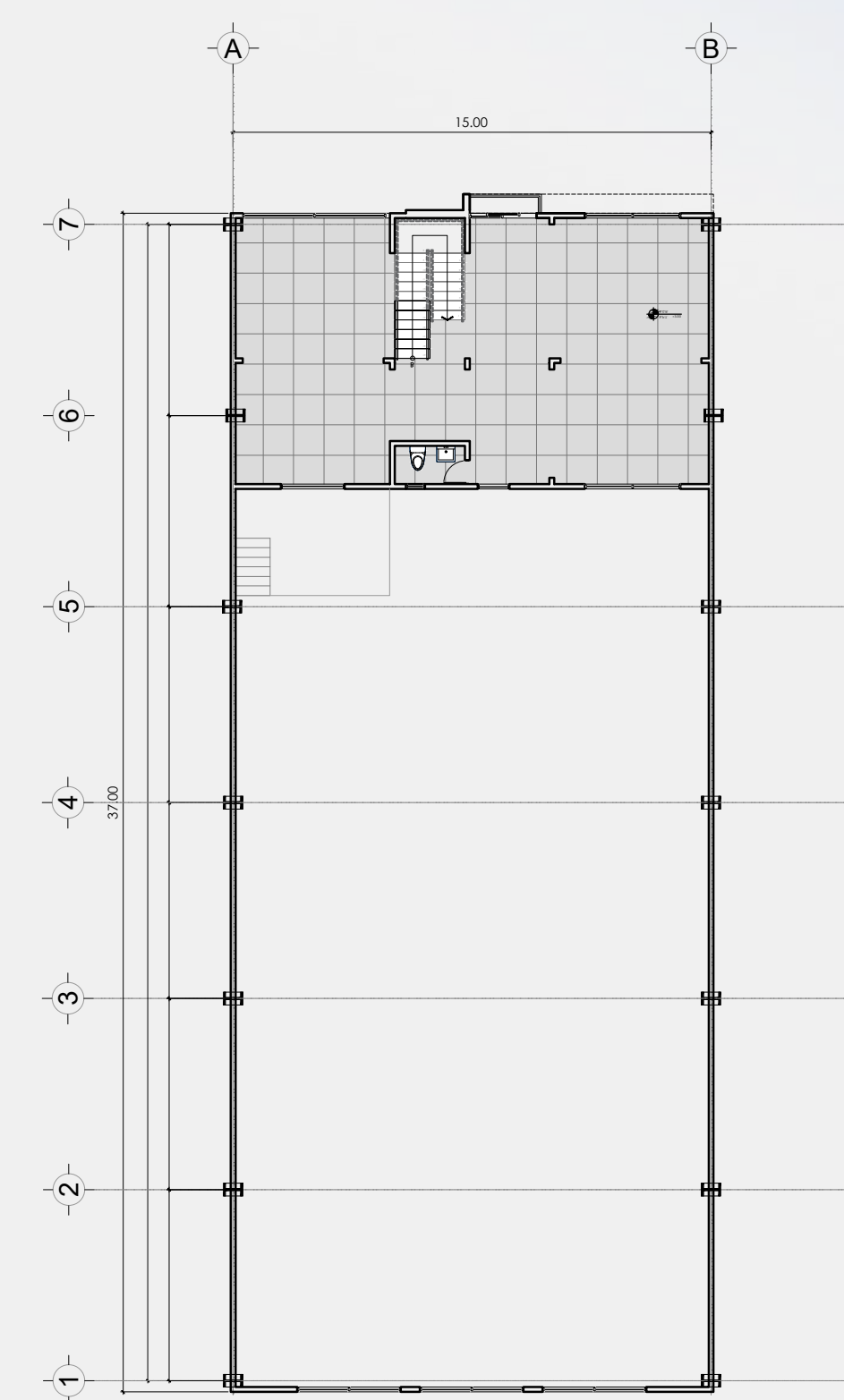

PLANTA MEZZANINE



MODELO T5
D26-D32

Diseño e imágenes con fines ilustrativos; nos reservamos a cambios sin previo aviso

MODELO T6

D19-D25

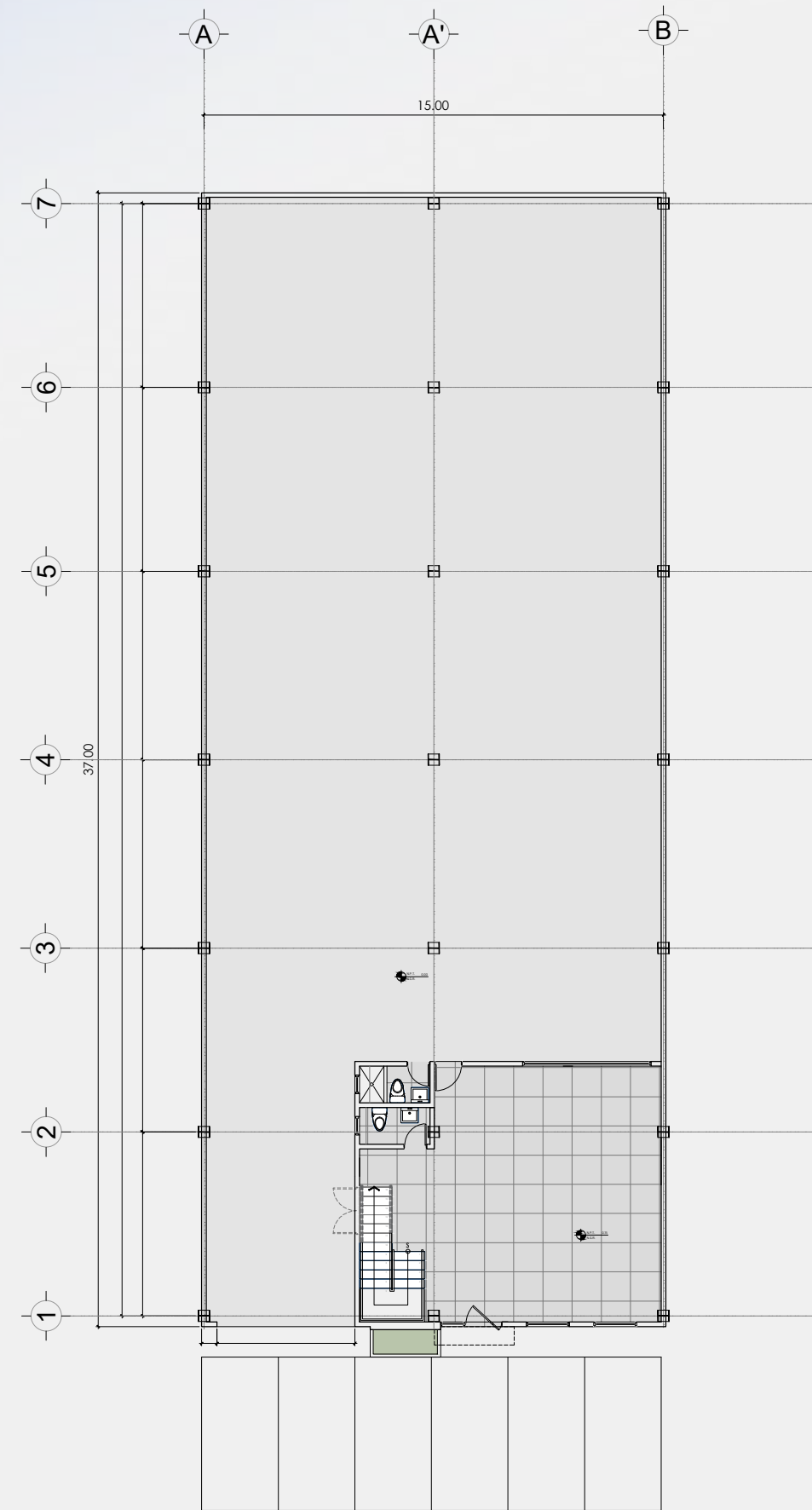

PLANTA PRIMER NIVEL

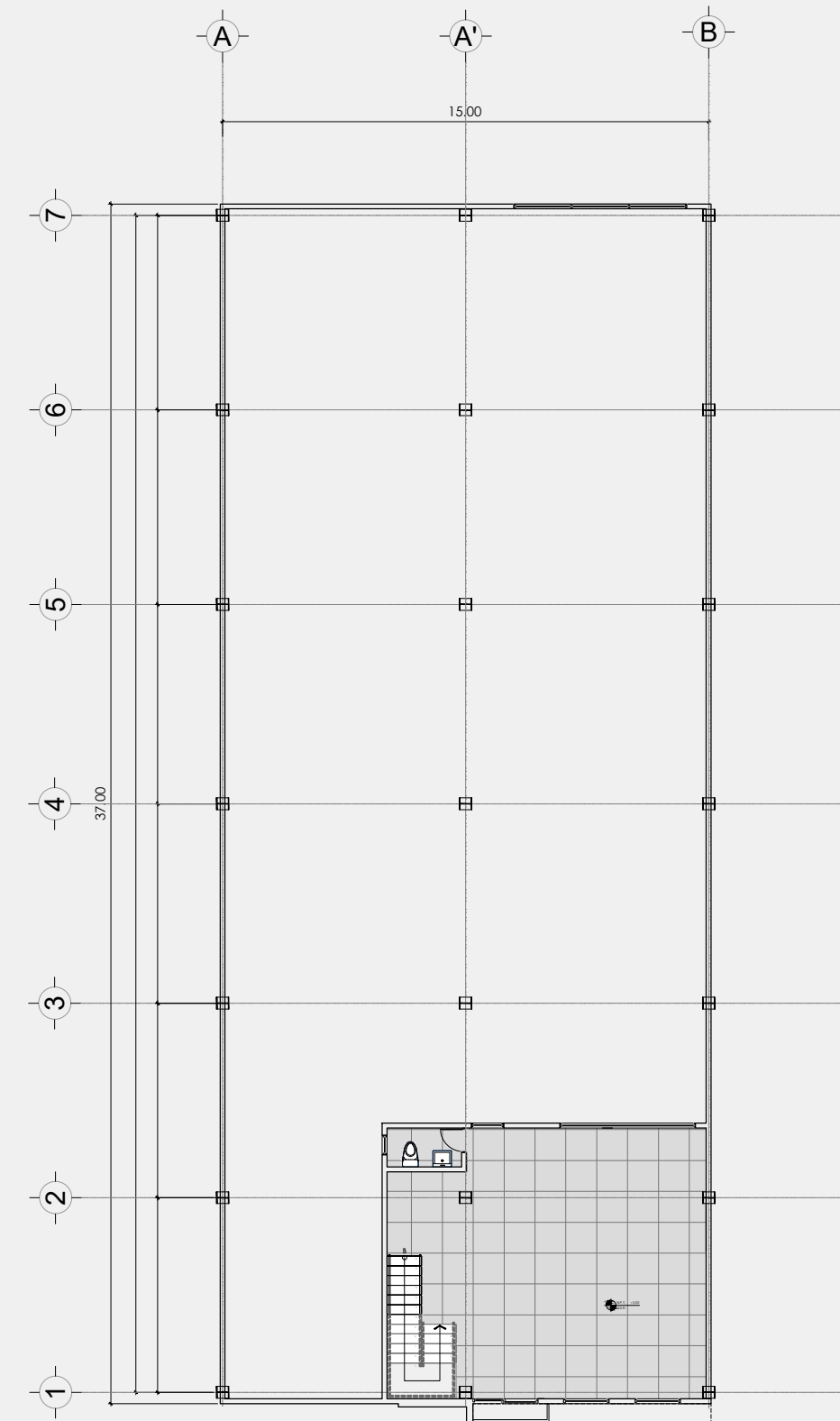

PLANTA MEZZANINE

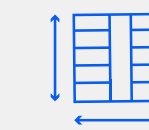

15*37 mts²

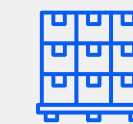

467.85 mts² de bodega



180.30 mts² de oficina



648.15 mts² de construcción



3,000 kg/mt² capacidad de soporte



3 baños



6 parqueos



Sin Andén

(*Bodegas Planta Baja)



MODELO T6
D19-D25

Diseño e imágenes con fines ilustrativos; nos reservamos a cambios sin previo aviso

MODELO T7

C67-C70

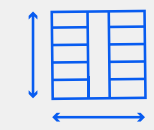

15*29 mts²

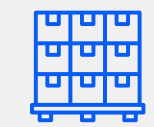

360.95 mts² de bodega



190.50 mts² de oficina



551.45 mts² de construcción



3,000 kg/mt² capacidad de soporte



3 baños



6 parqueos



Con Andén

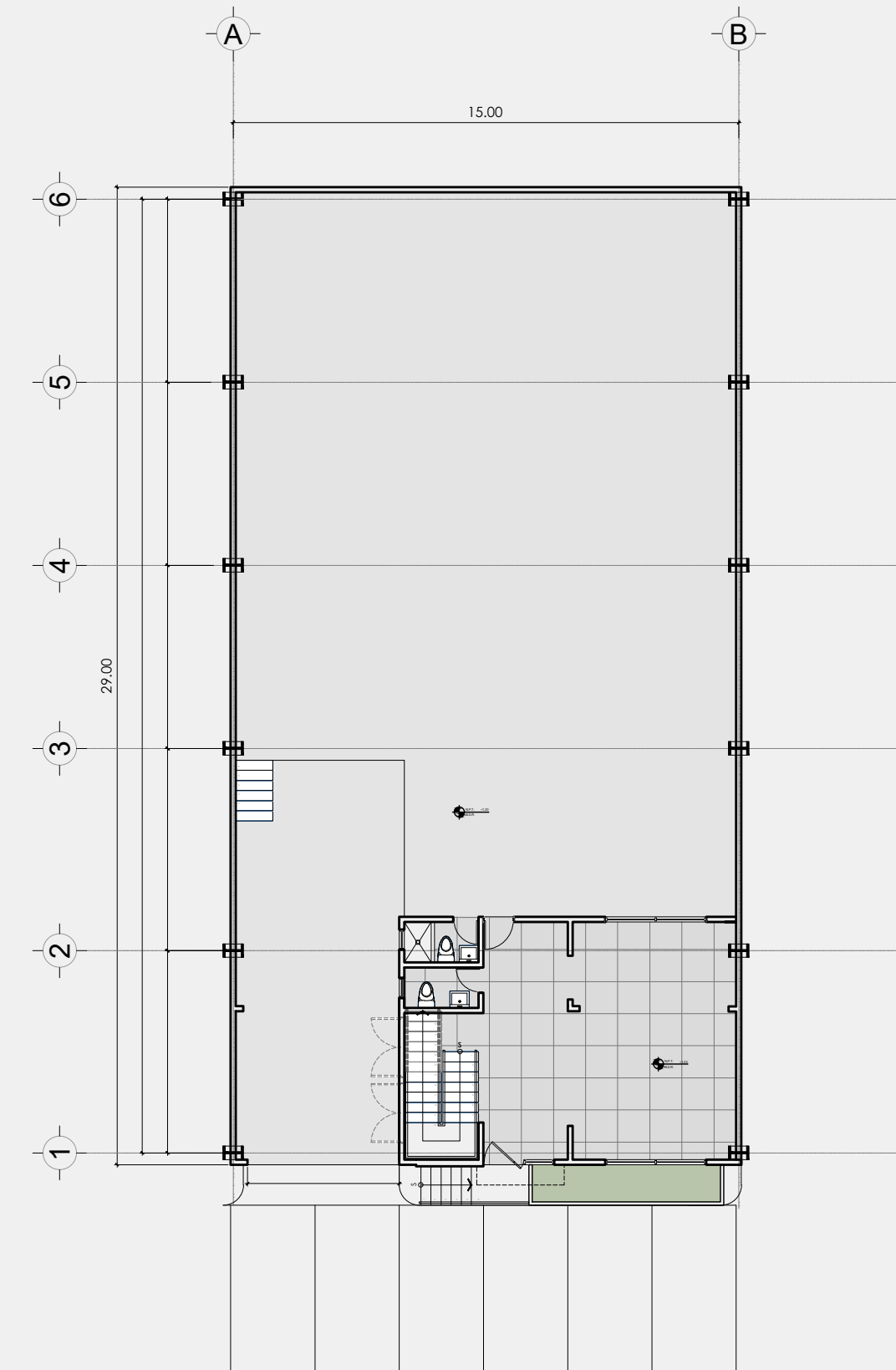

PLANTA PRIMER NIVEL

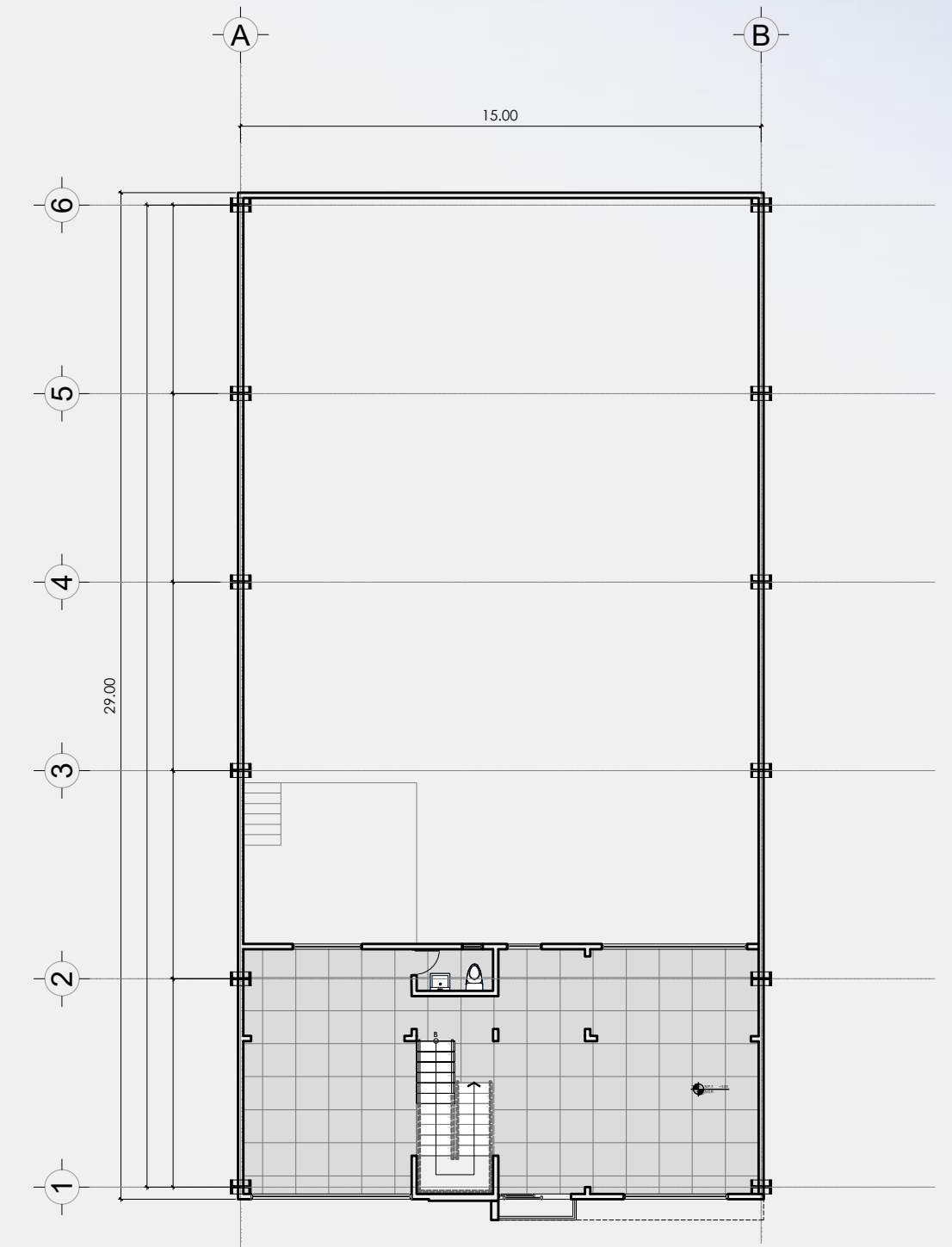

PLANTA MEZZANINE



C67

C68

LOGO

LOGO

MODELO T7
C67-C70

Diseño e imágenes con fines ilustrativos; nos reservamos a cambios sin previo aviso

MODELO T8

C74-C76

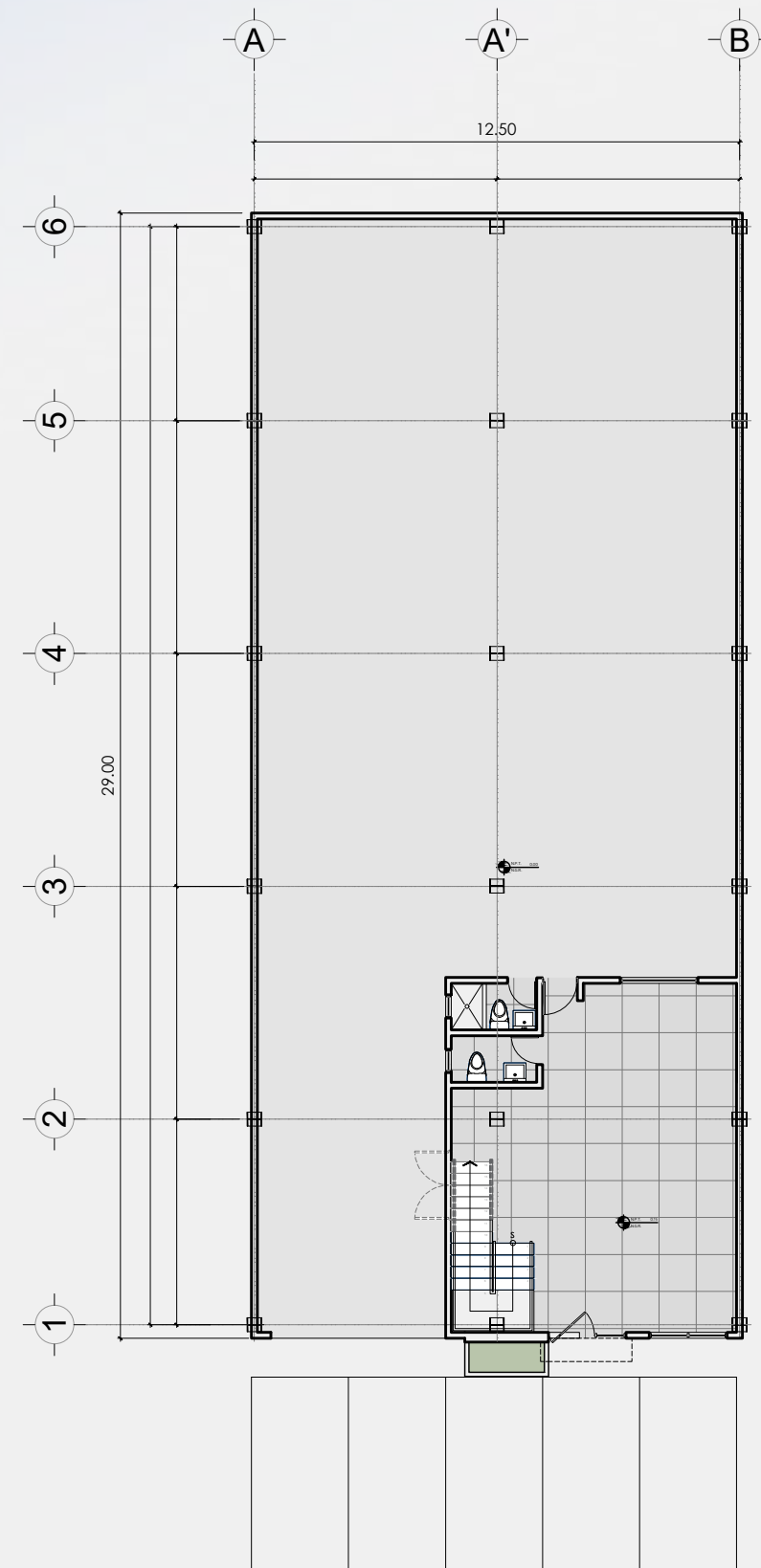

PLANTA PRIMER NIVEL

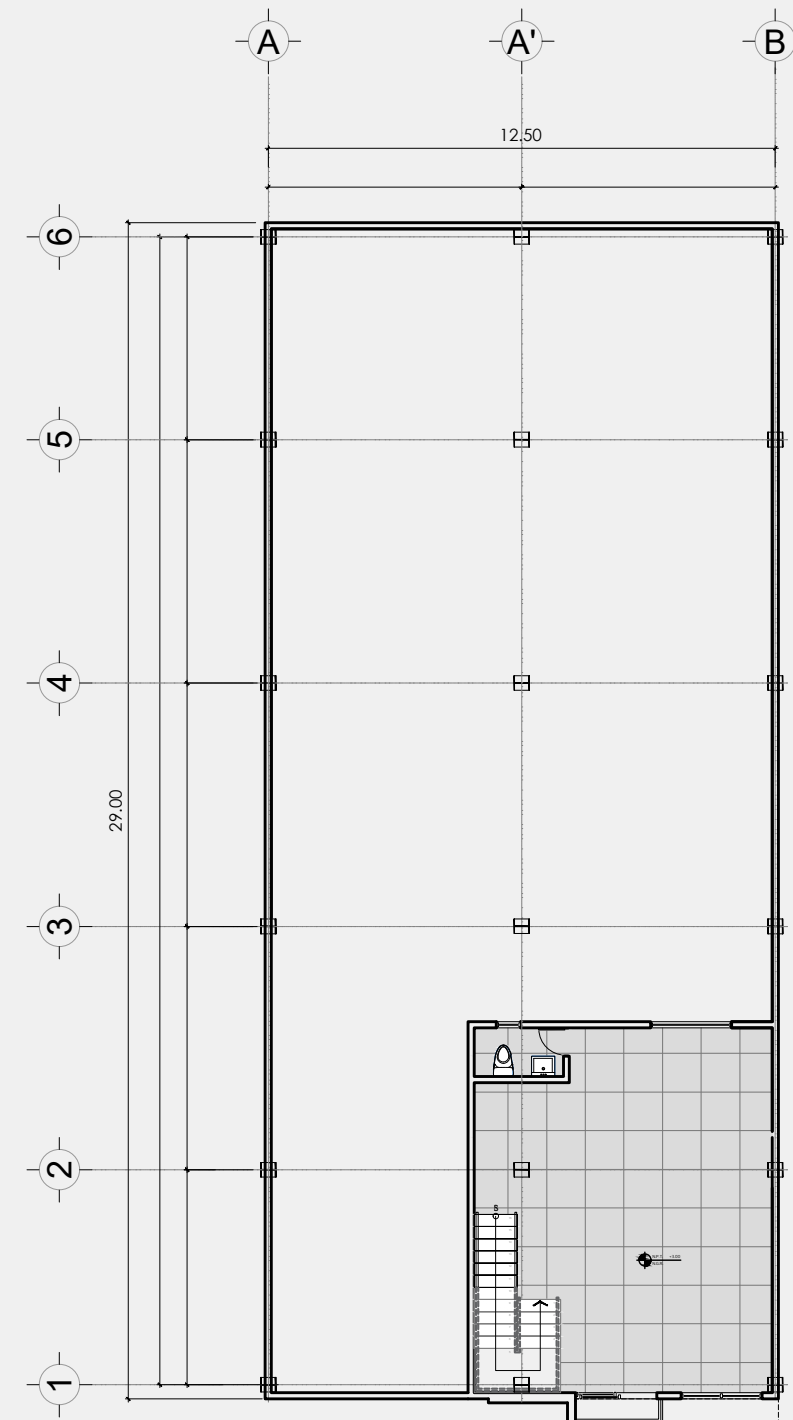

PLANTA MEZZANINE

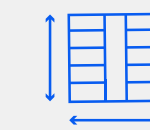

12.50*29 mts²

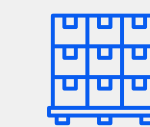

292.05 mts² de bodega



145.34 mts² de oficina



437.39 mts² de construcción



3,000 kg/mt² capacidad de soporte



3 baños



5 parqueos



Sin Andén

(*Bodegas Planta Baja)



C76

C75

MODELO T8
C74-C76

Diseño e imágenes con fines ilustrativos; nos reservamos a cambios sin previo aviso

MODELO T9

D9-D18

D9-D12

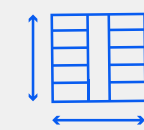

Desde 10*20 mts²

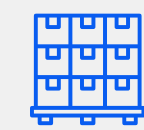

Desde 160.92 mts² de bodega



Desde 119.07 mts² de oficina



Desde 280 mts² de construcción



3,000 kg/mt² capacidad de soporte



3 baños



4 parqueos



Con Andén

*Atípicas D13-D18

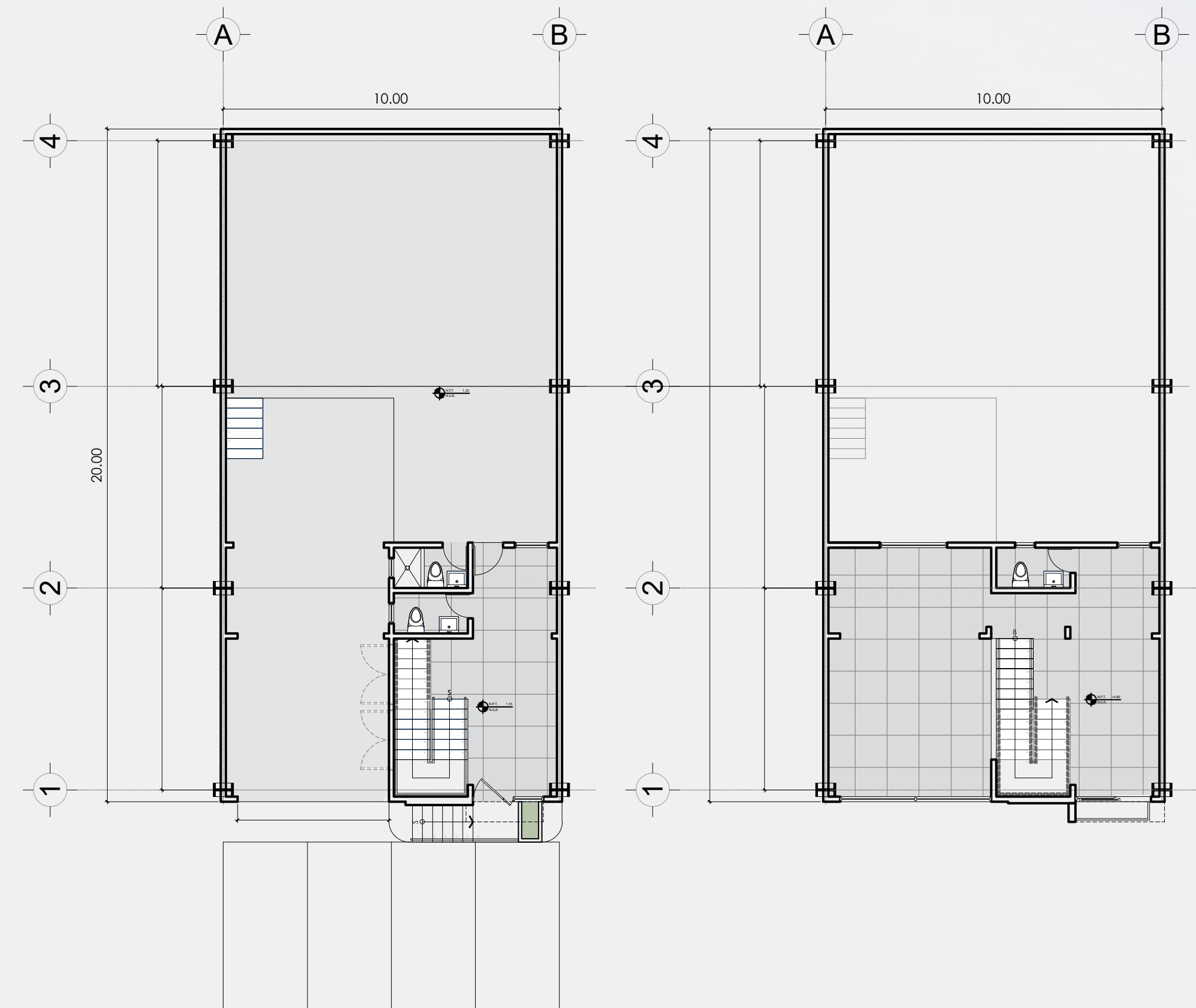

PLANTA PRIMER NIVEL

PLANTA MEZZANINE



D14

D15

D16

LOGO

LOGO

LOGO

MODELO T9
D9-D18

Diseño e imágenes con fines ilustrativos; nos reservamos a cambios sin previo aviso

MODELO T10

C71-C73

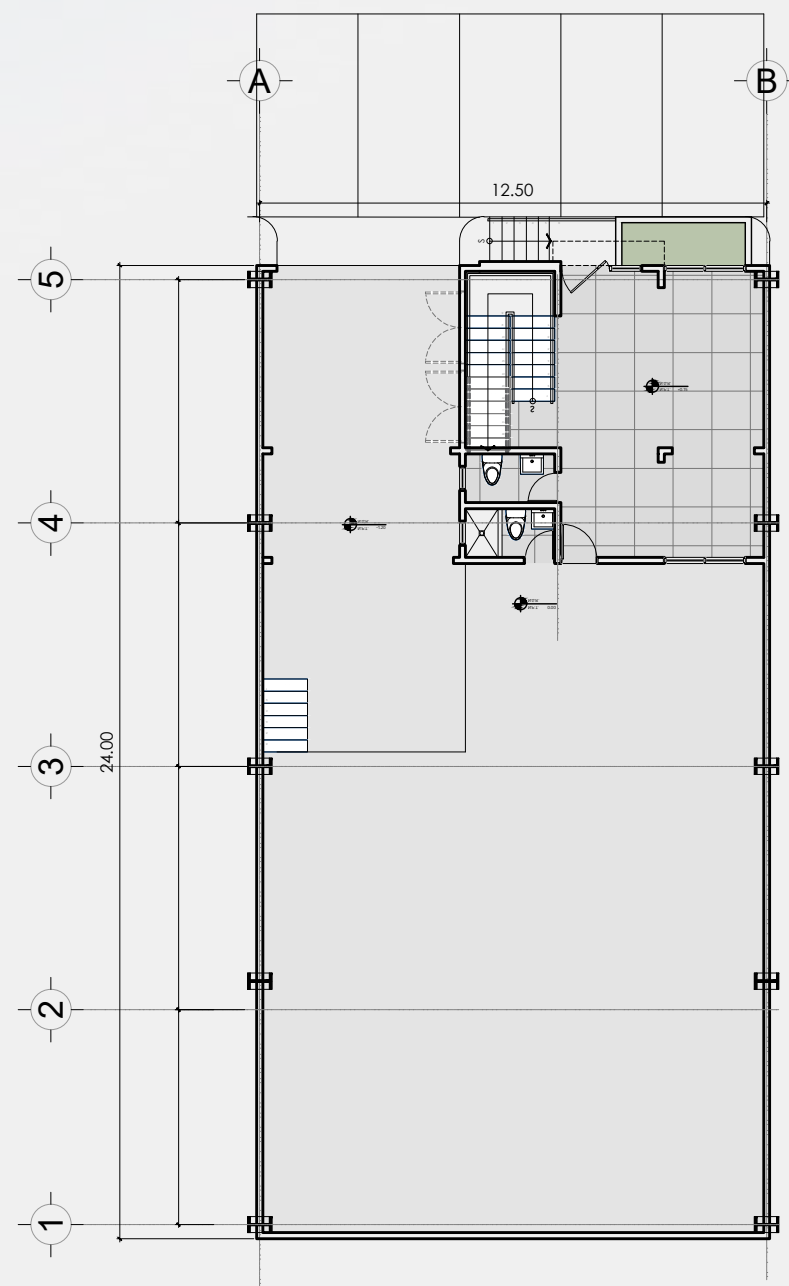

PLANTA PRIMER NIVEL

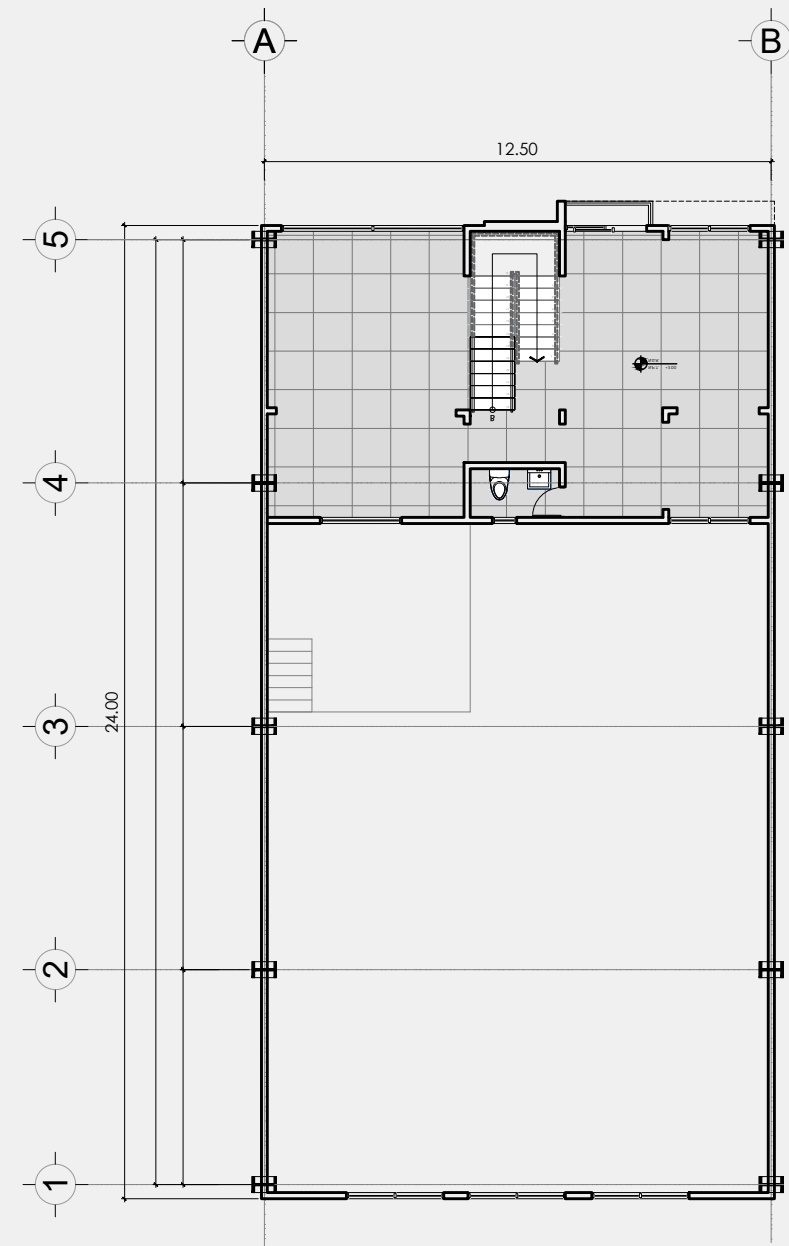

PLANTA MEZZANINE

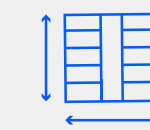

12.50*24 mts²

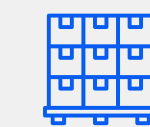

244.32 mts² de bodega



152.32 mts² de oficina



396.64 mts² de construcción



2,000 kg/mt² capacidad de soporte



3 baños



5 parqueos



Con Andén



C 72

C 71

MODELO T10
C71-C73

Diseño e imágenes con fines ilustrativos; nos reservamos a cambios sin previo aviso



LOS MEJORES ESTÁNDARES
de calidad estructural y eficiencia logística



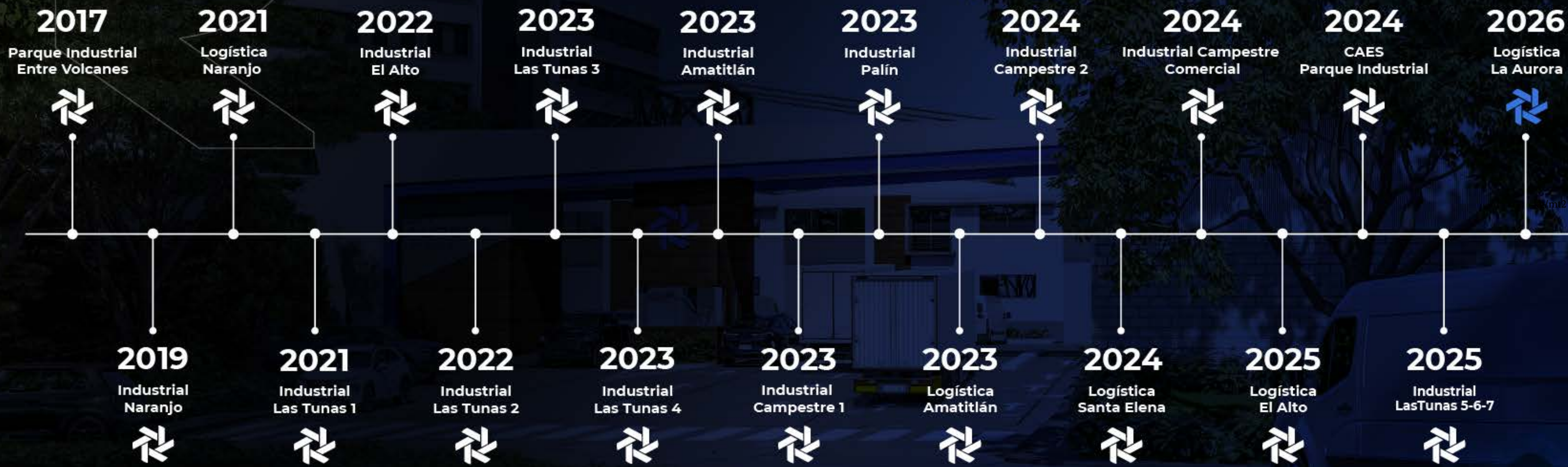

UTROR



LA AURORA LOGÍSTICA



LA AURORA LOGÍSTICA

Desarrollado por:



AURORA