



CENTRAL 200

SAN PEDRO G.G.



CENTRAL 200

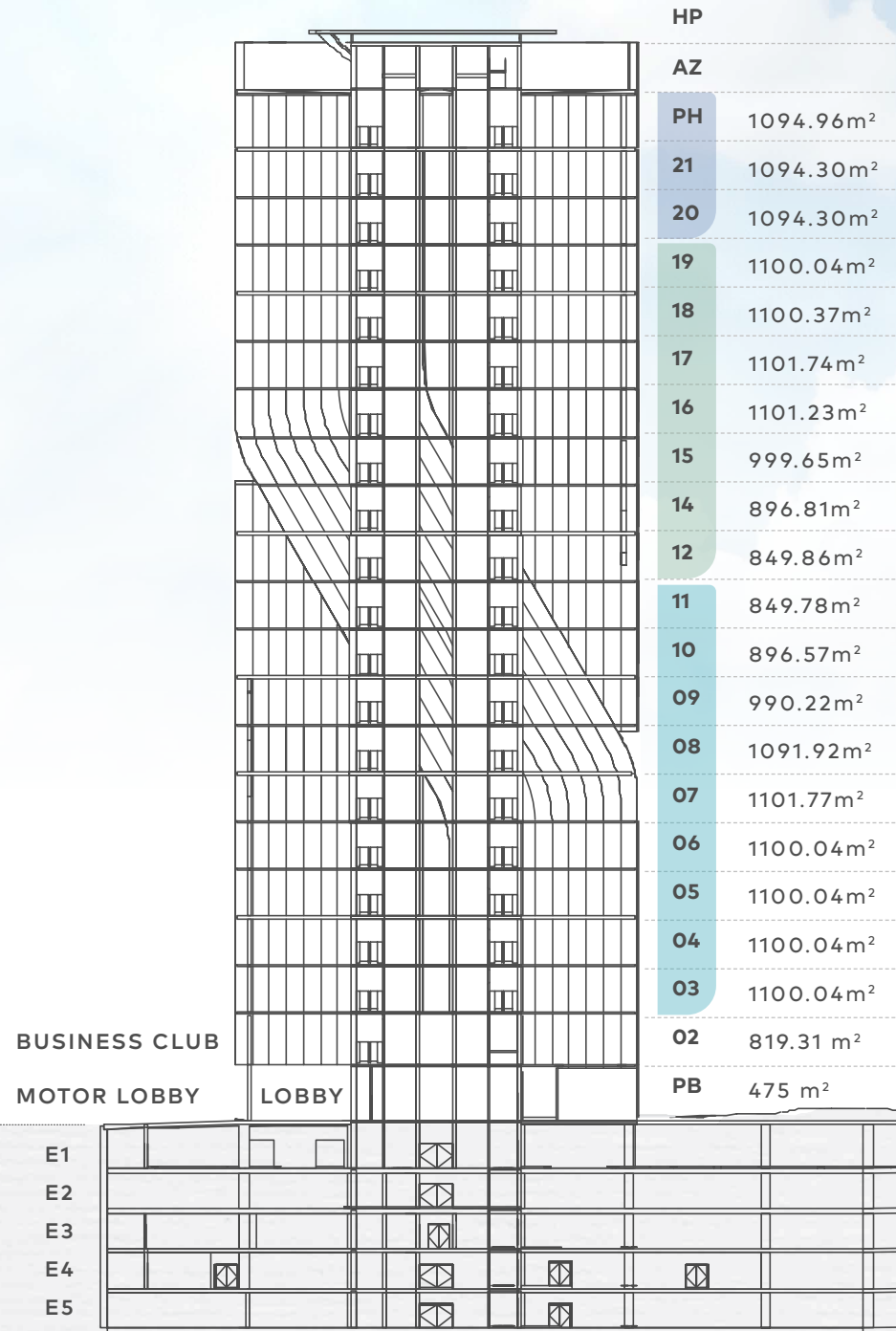

- s.1 72 cajones VIP
- s.2
- s.3 296 cajones
- s.4 332 cajones
- s.5 331 cajones



CENTRAL 200

UNIDAD

LOBBY

NIVEL

PB

ÁREA

475 M²

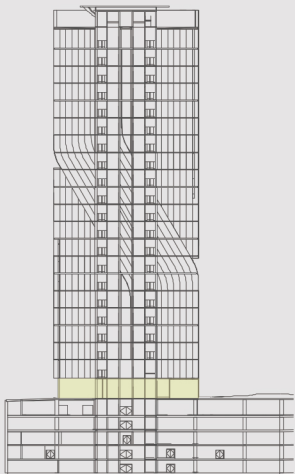

AVENIDA DE LA INDUSTRIA

CALLE DEL COMERCIO

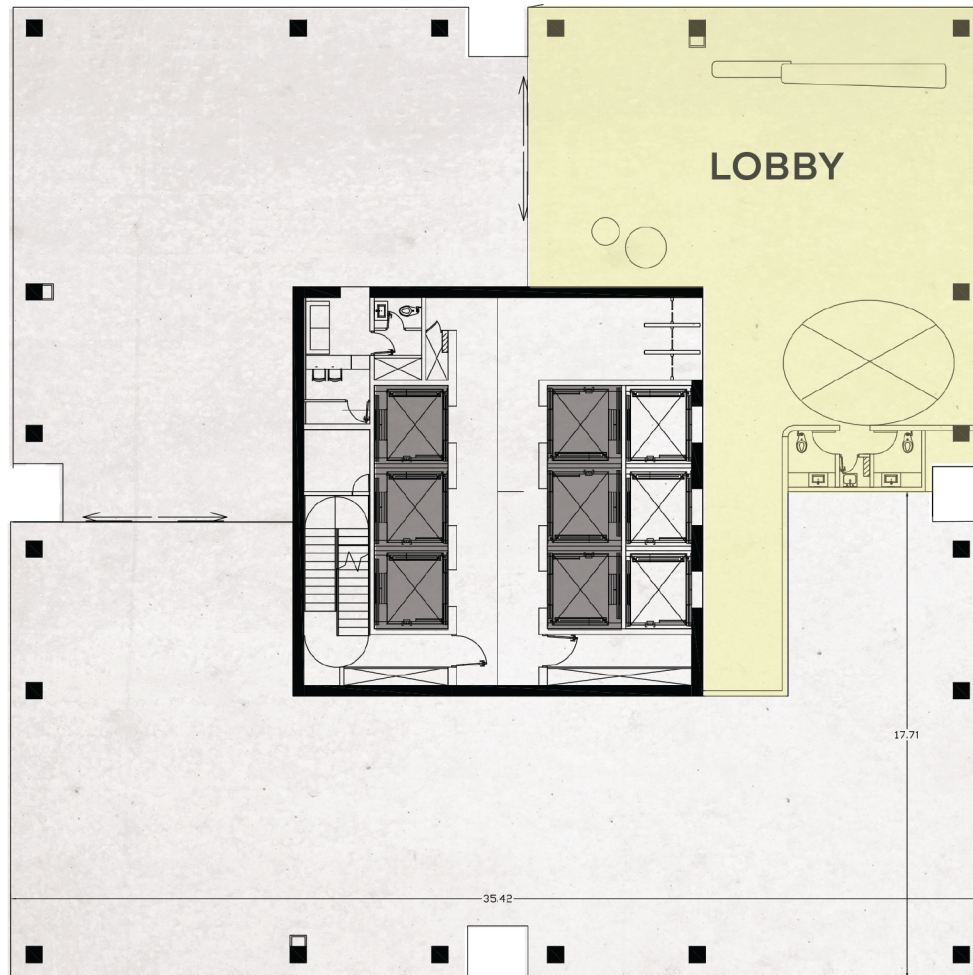



CENTRAL 200

UNIDAD

201

NIVEL

02

ÁREA

541 M²

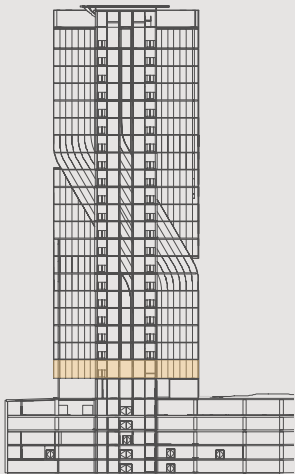

CALLE DEL COMERCIO

AVENIDA DE LA INDUSTRIA

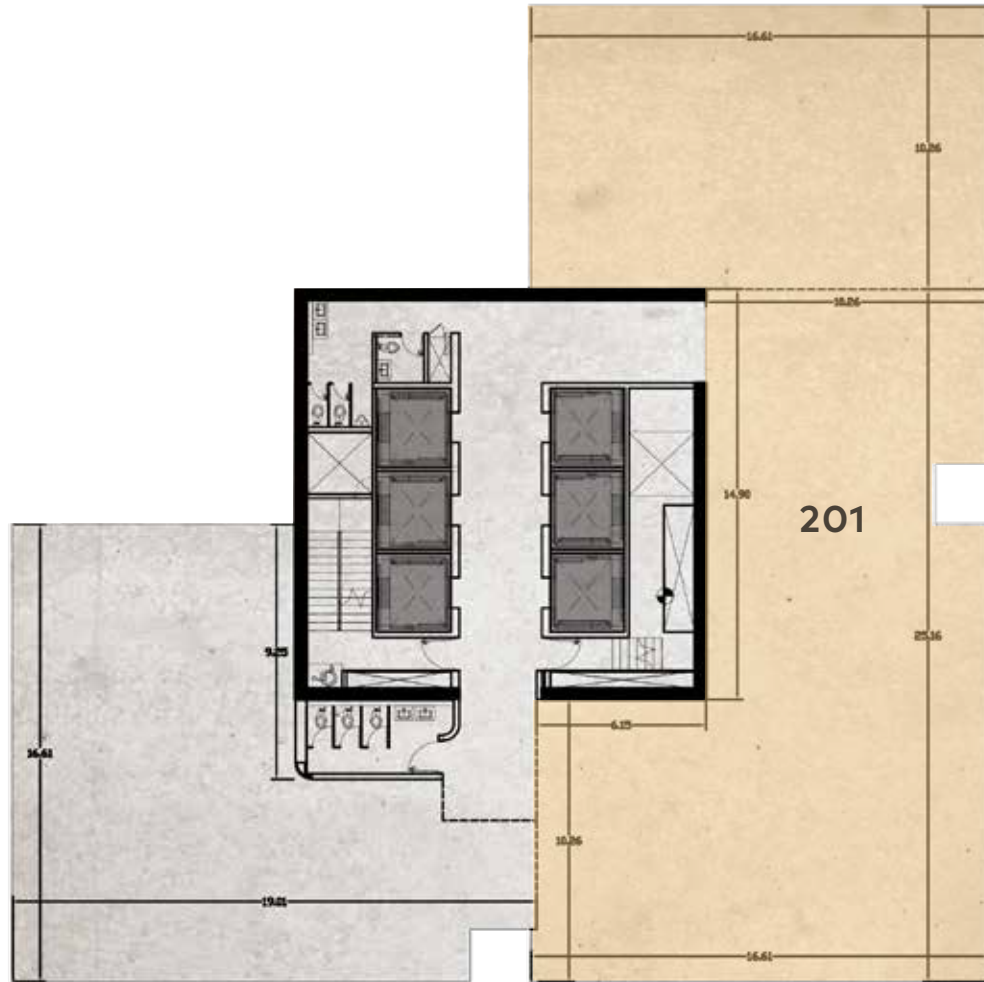

DESGLOSE DE ÁREAS

Oficina	487.81 m ²
Sanitarios	14.14 m ²
Área Común (Lobby)	39 m ²
Área Total	540.97 m ²



CENTRAL 200

UNIDAD

202

NIVEL

02

ÁREA

278 M²

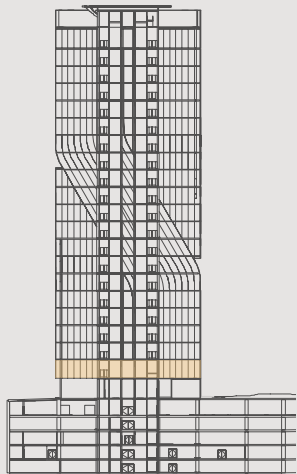

CALLE DEL COMERCIO

AVENIDA DE LA INDUSTRIA

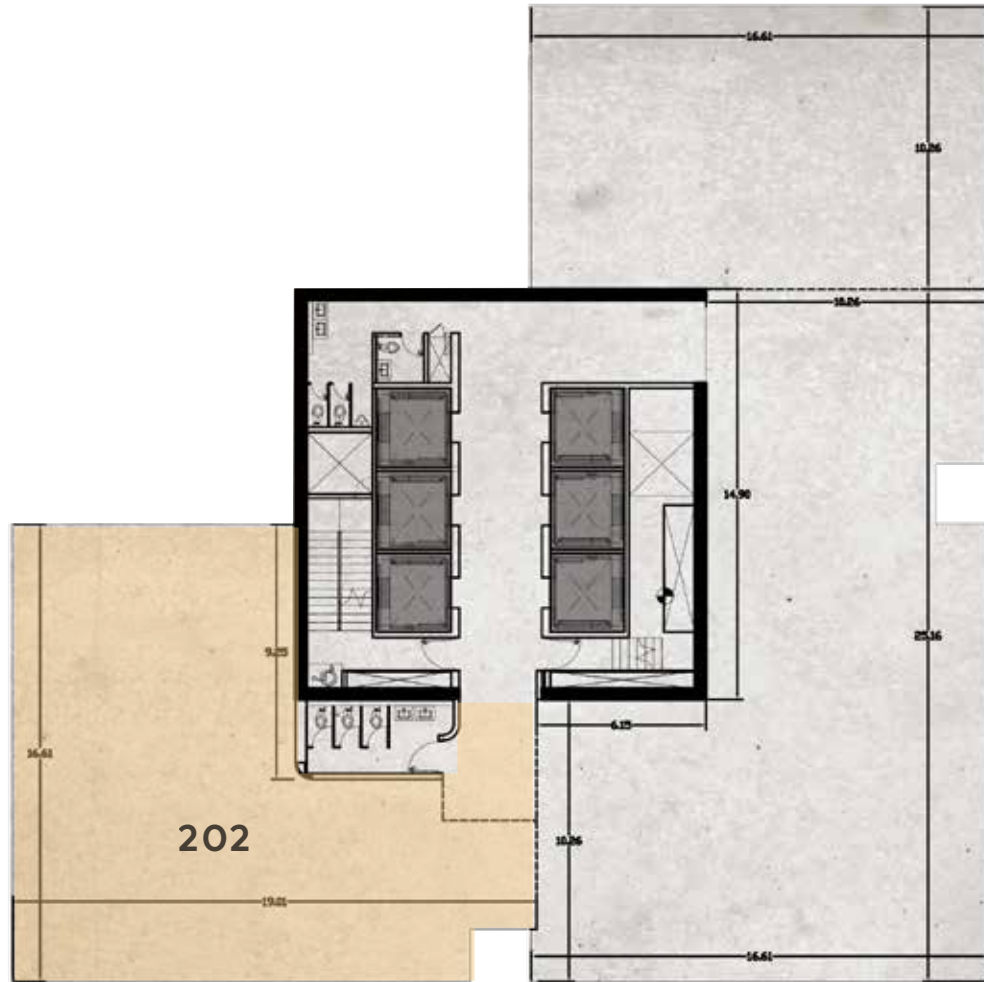

DESGLOSE DE ÁREAS

Oficina	225.17 m ²
Sanitarios	14.14 m ²
Área Común (Lobby)	39 m ²
Área Total	278.34 m ²



CENTRAL 200

UNIDAD

301

NIVEL

03

ÁREA

275 M²

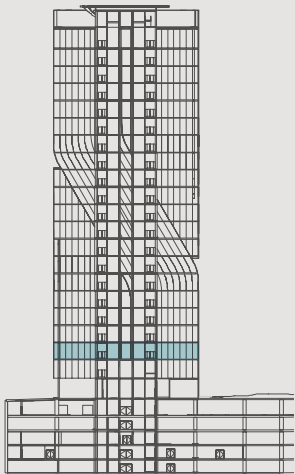

CALLE DEL COMERCIO

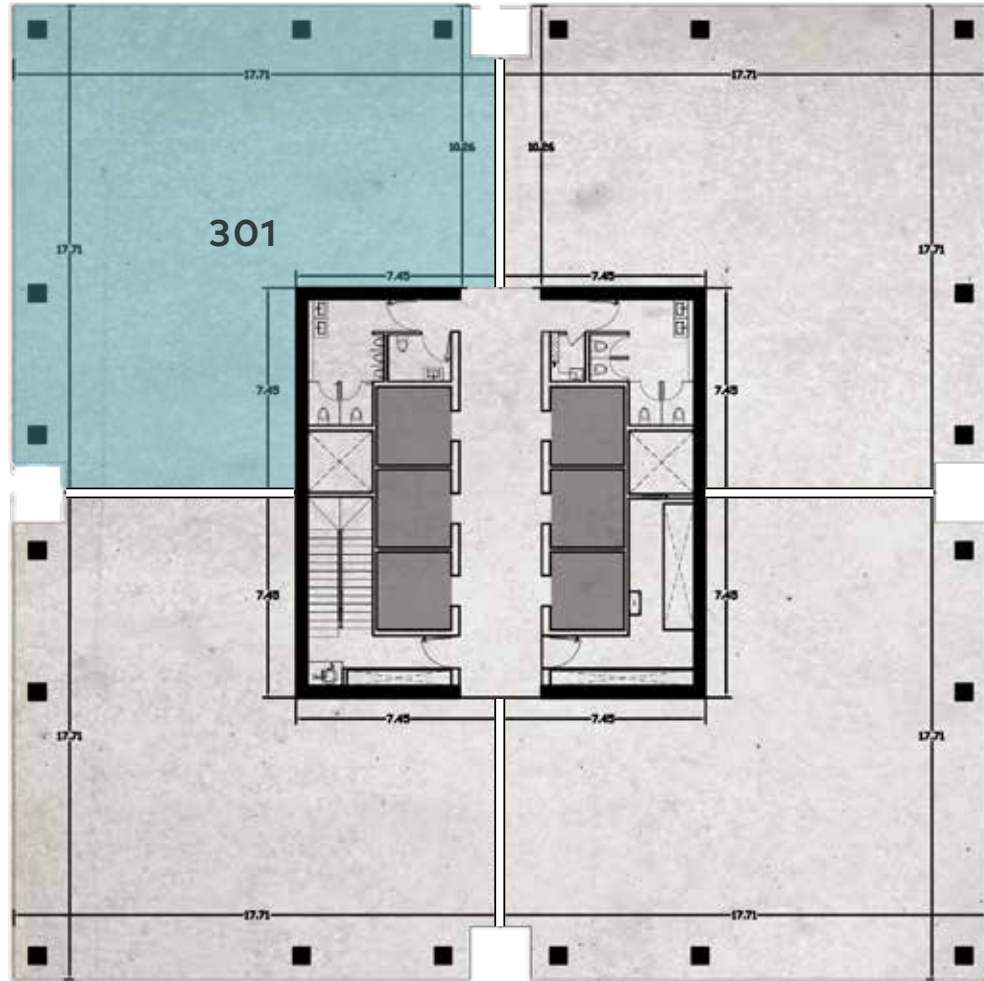

AVENIDA DE LA INDUSTRIA

DESGLOSE DE ÁREAS

Oficina	253.94 m ²
Sanitarios	9.27 m ²
Área Común (Lobby)	11.80 m ²
Área Total	275.01 m ²



CENTRAL 200

UNIDAD

302

NIVEL

03

ÁREA

275 M²

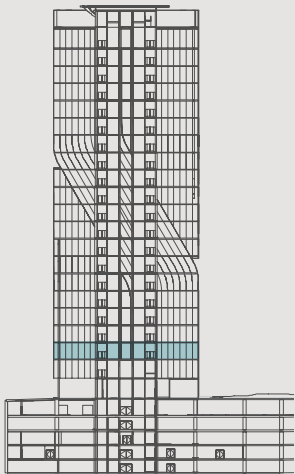

CALLE DEL COMERCIO

AVENIDA DE LA INDUSTRIA

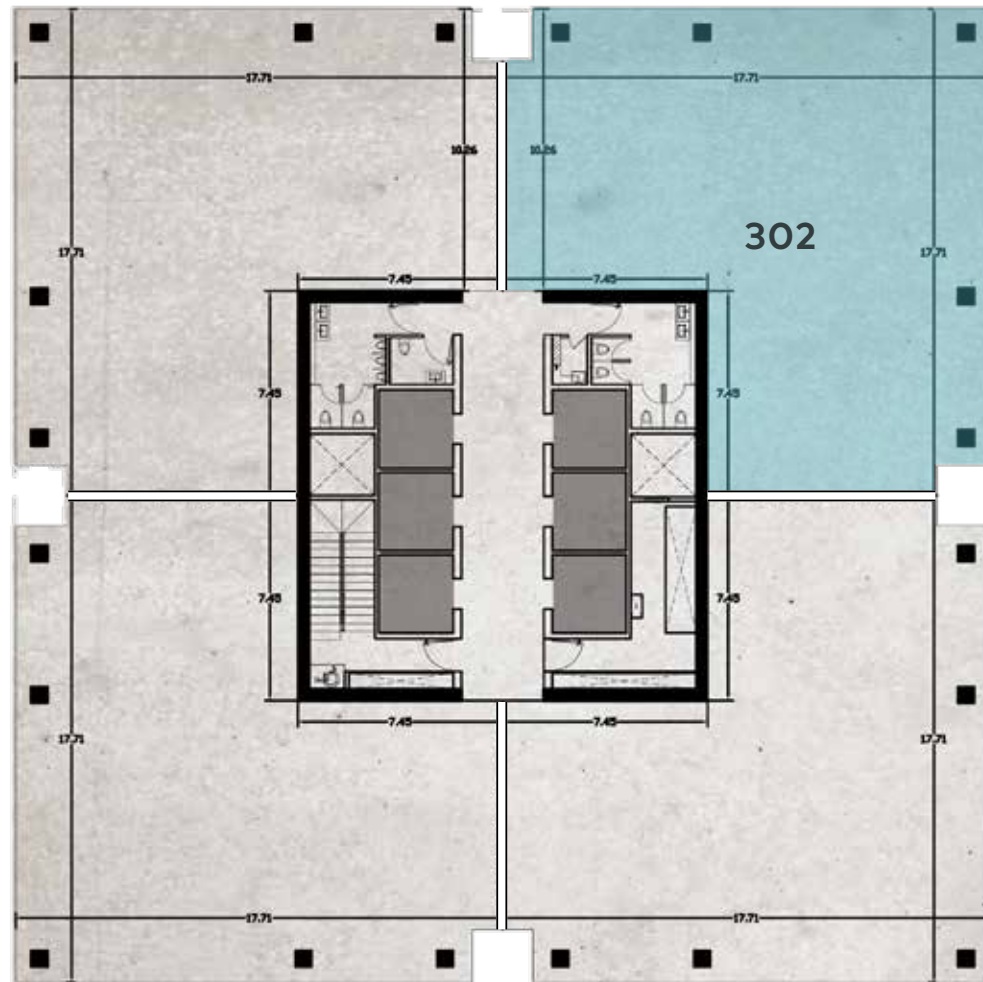

DESGLOSE DE ÁREAS

Oficina	253.94 m ²
Sanitarios	9.27 m ²
Área Común (Lobby)	11.80 m ²
Área Total	275.01 m ²



CENTRAL 200

UNIDAD

303

NIVEL

03

ÁREA

275 M²

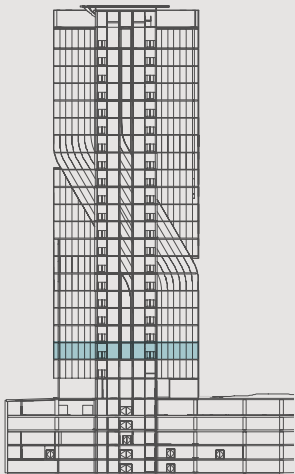

CALLE DEL COMERCIO

AVENIDA DE LA INDUSTRIA

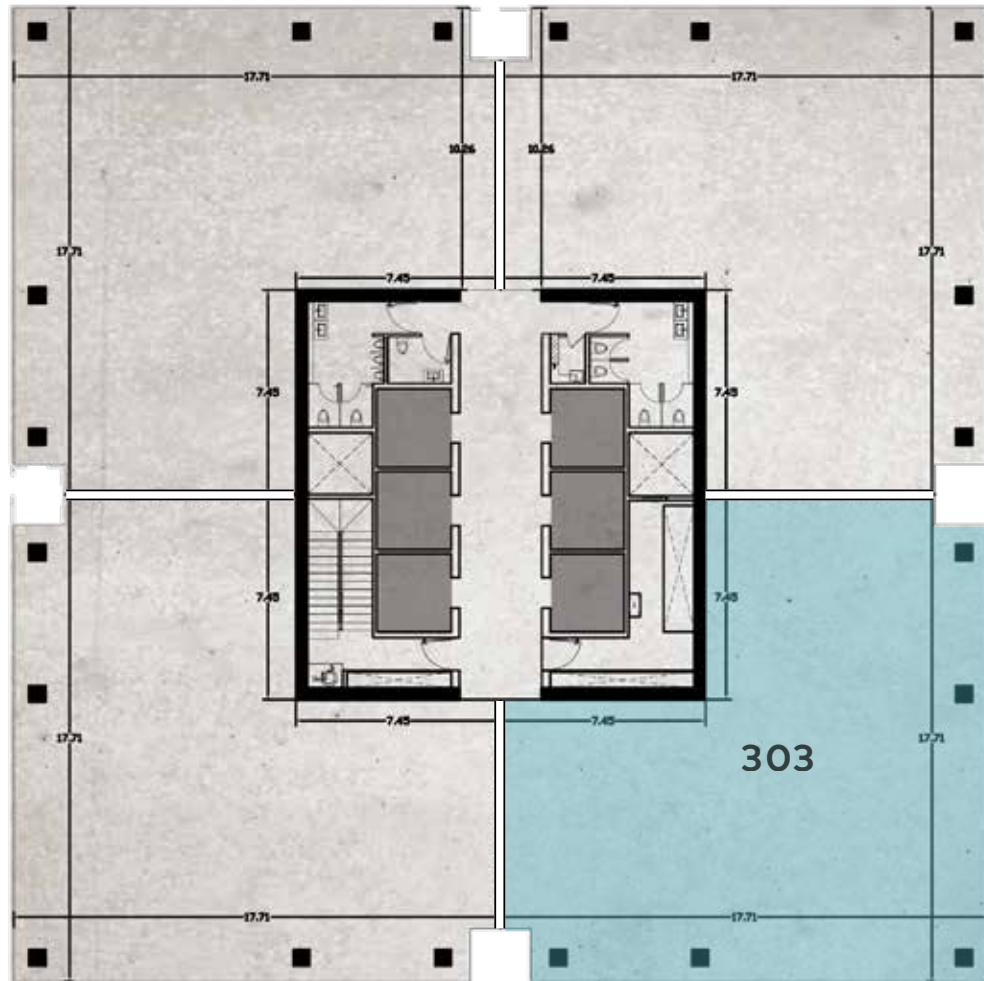

DESGLOSE DE ÁREAS

Oficina	253.94 m ²
Sanitarios	9.27 m ²
Área Común (Lobby)	11.80 m ²
Área Total	275.01 m ²



CENTRAL 200

UNIDAD

304

NIVEL

03

ÁREA

275 M²

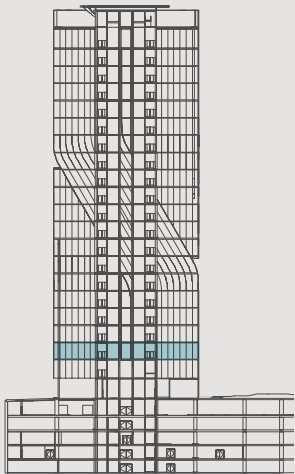

CALLE DEL COMERCIO

AVENIDA DE LA INDUSTRIA

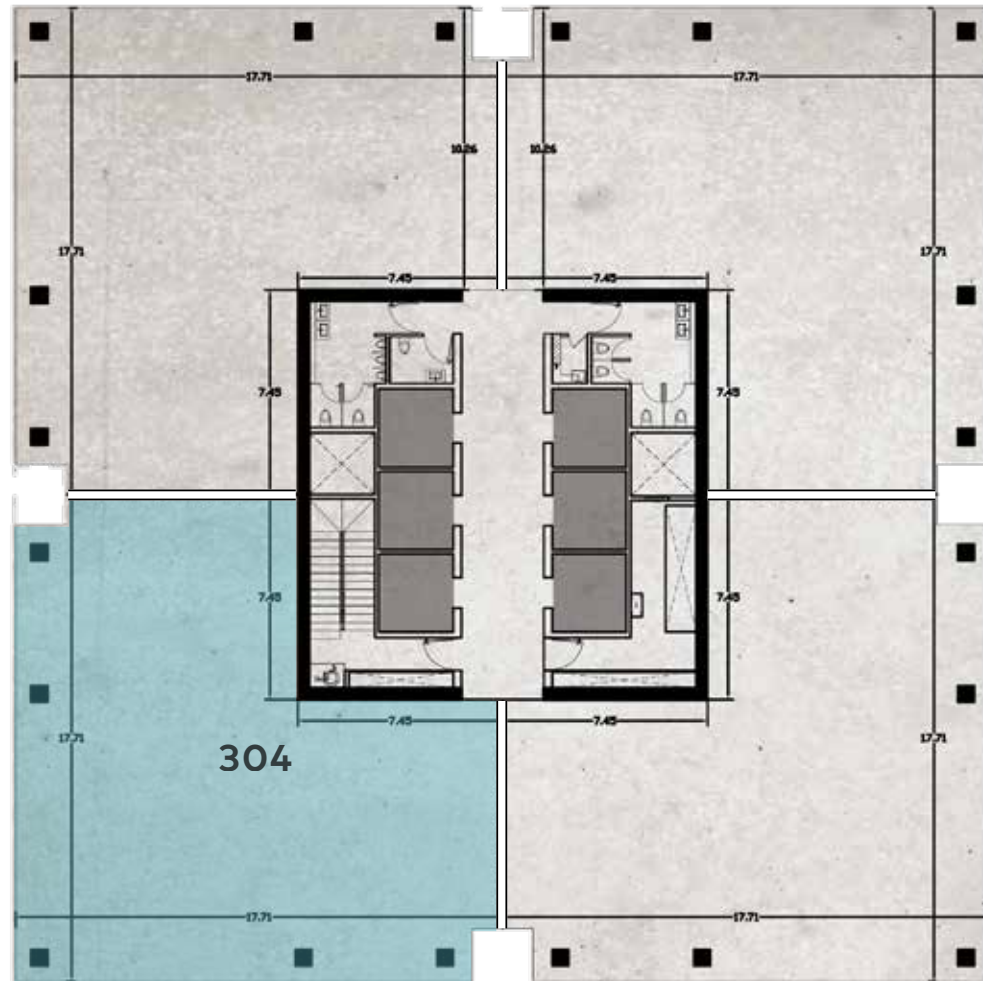

DESGLOSE DE ÁREAS

Oficina	253.94 m ²
Sanitarios	9.27 m ²
Área Común (Lobby)	11.80 m ²
Área Total	275.01 m ²



CENTRAL 200

UNIDAD

401

NIVEL

04

ÁREA

275 M²

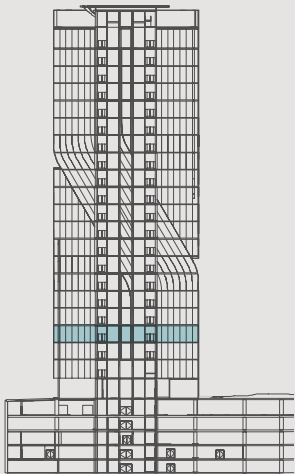

CALLE DEL COMERCIO

AVENIDA DE LA INDUSTRIA

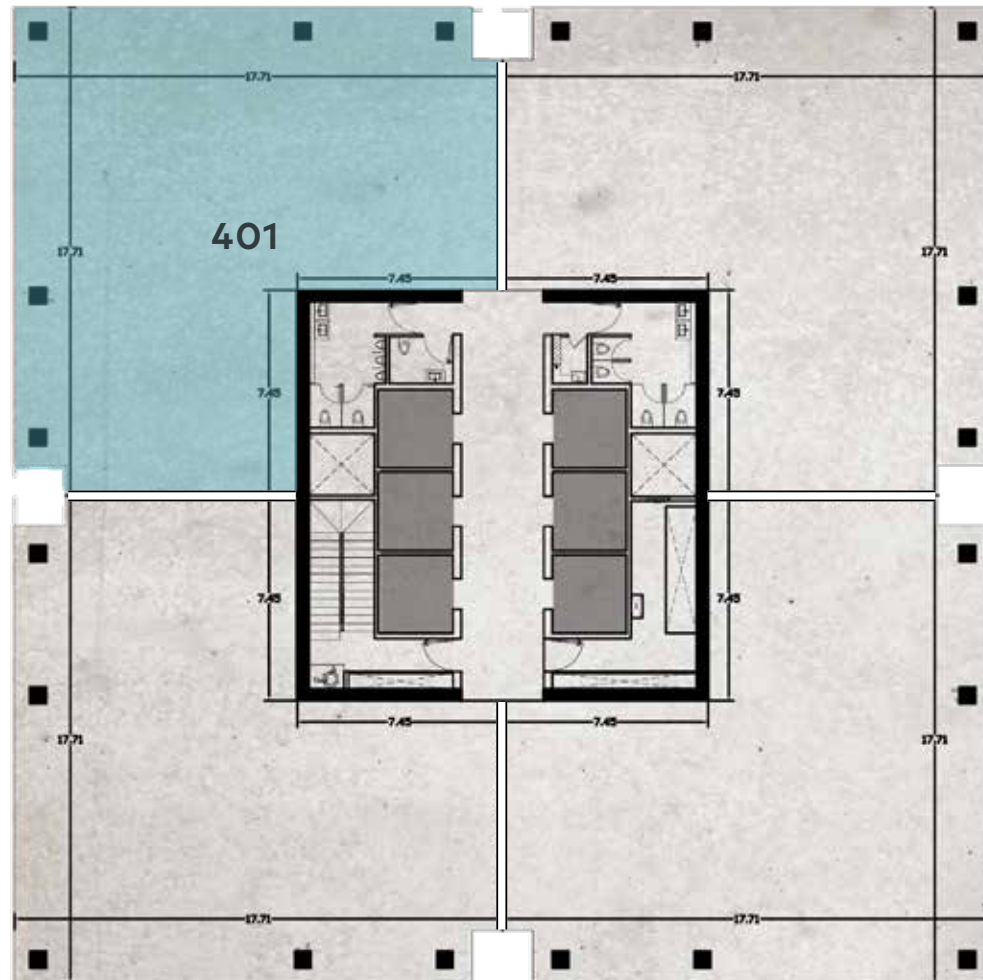

DESGLOSE DE ÁREAS

Oficina	253.94 m ²
Sanitarios	9.27 m ²
Área Común (Lobby)	11.80 m ²
Área Total	275.01 m ²



CENTRAL 200

UNIDAD

402

NIVEL

04

ÁREA

275 M²

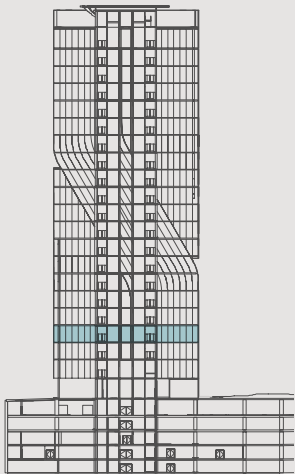

CALLE DEL COMERCIO

AVENIDA DE LA INDUSTRIA

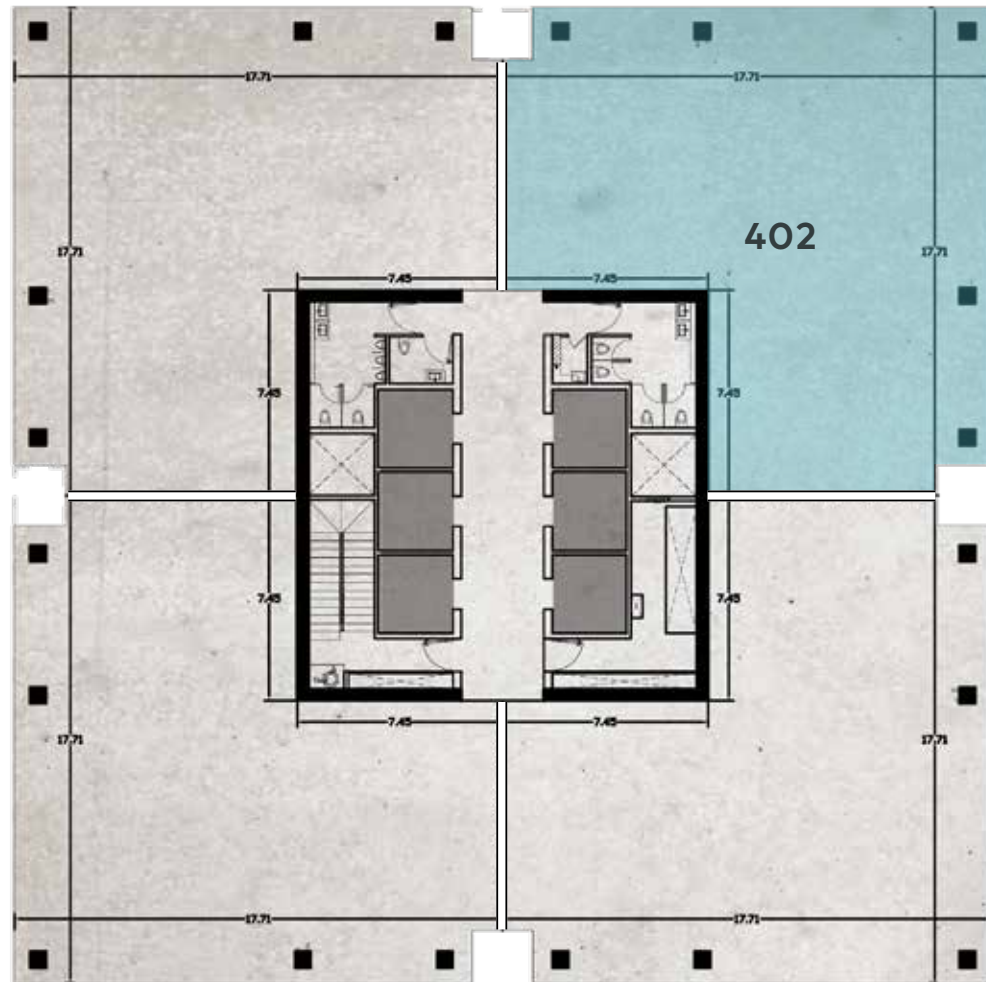

DESGLOSE DE ÁREAS

Oficina	253.94 m ²
Sanitarios	9.27 m ²
Área Común (Lobby)	11.80 m ²
Área Total	275.01 m ²



CENTRAL 200

UNIDAD

403

NIVEL

04

ÁREA

275 M²

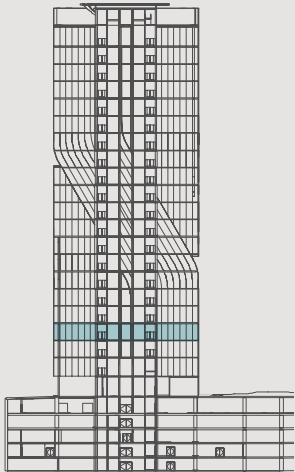

CALLE DEL COMERCIO

AVENIDA DE LA INDUSTRIA

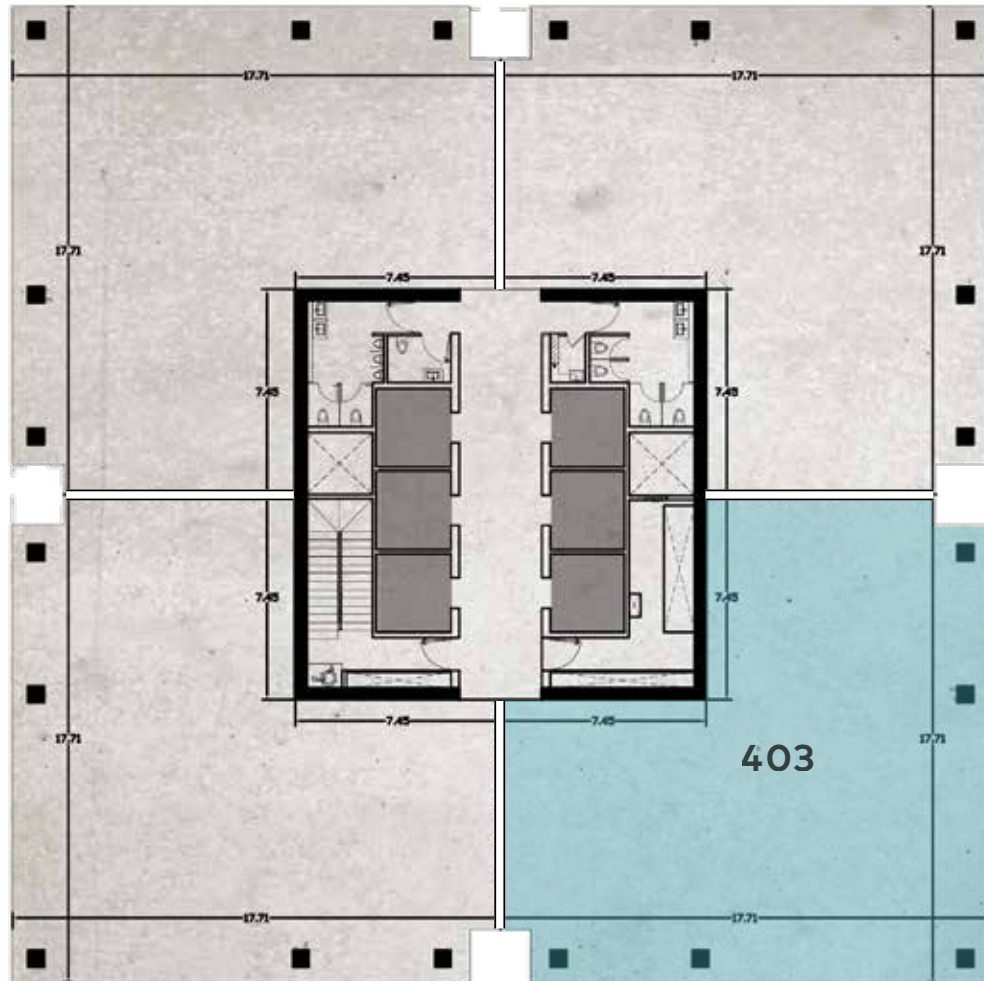

DESGLOSE DE ÁREAS

Oficina	253.94 m ²
Sanitarios	9.27 m ²
Área Común (Lobby)	11.80 m ²
Área Total	275.01 m ²



CENTRAL 200

UNIDAD

404

NIVEL

04

ÁREA

275 M²

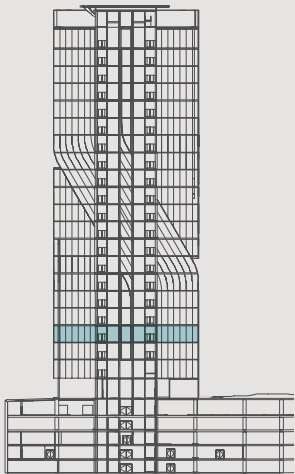

CALLE DEL COMERCIO

AVENIDA DE LA INDUSTRIA

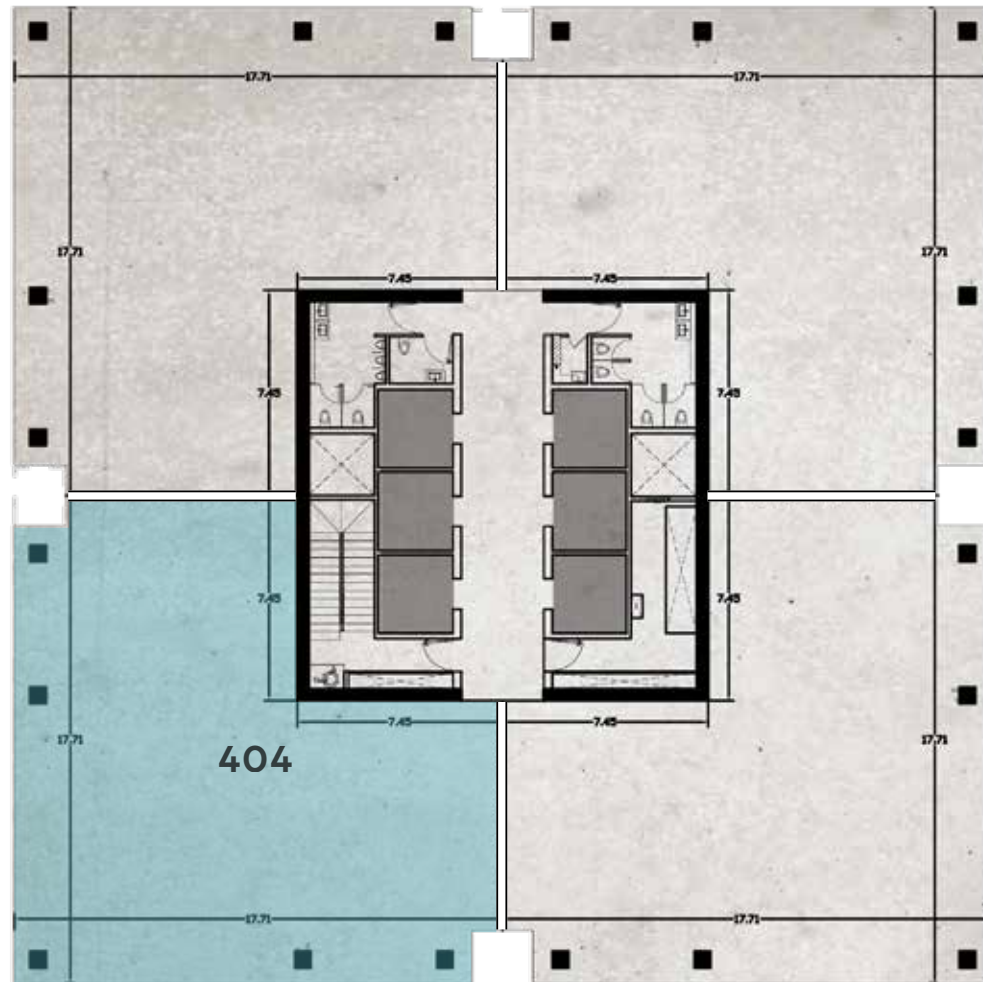

DESGLOSE DE ÁREAS

Oficina	253.94 m ²
Sanitarios	9.27 m ²
Área Común (Lobby)	11.80 m ²
Área Total	275.01 m ²



CENTRAL 200

UNIDAD

501

NIVEL

05

ÁREA

275 M²

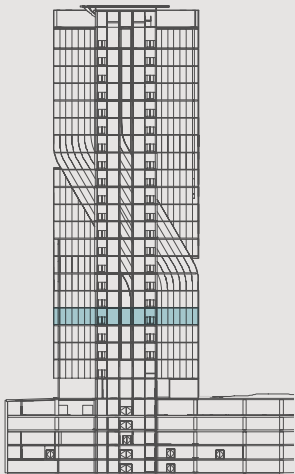

CALLE DEL COMERCIO

AVENIDA DE LA INDUSTRIA

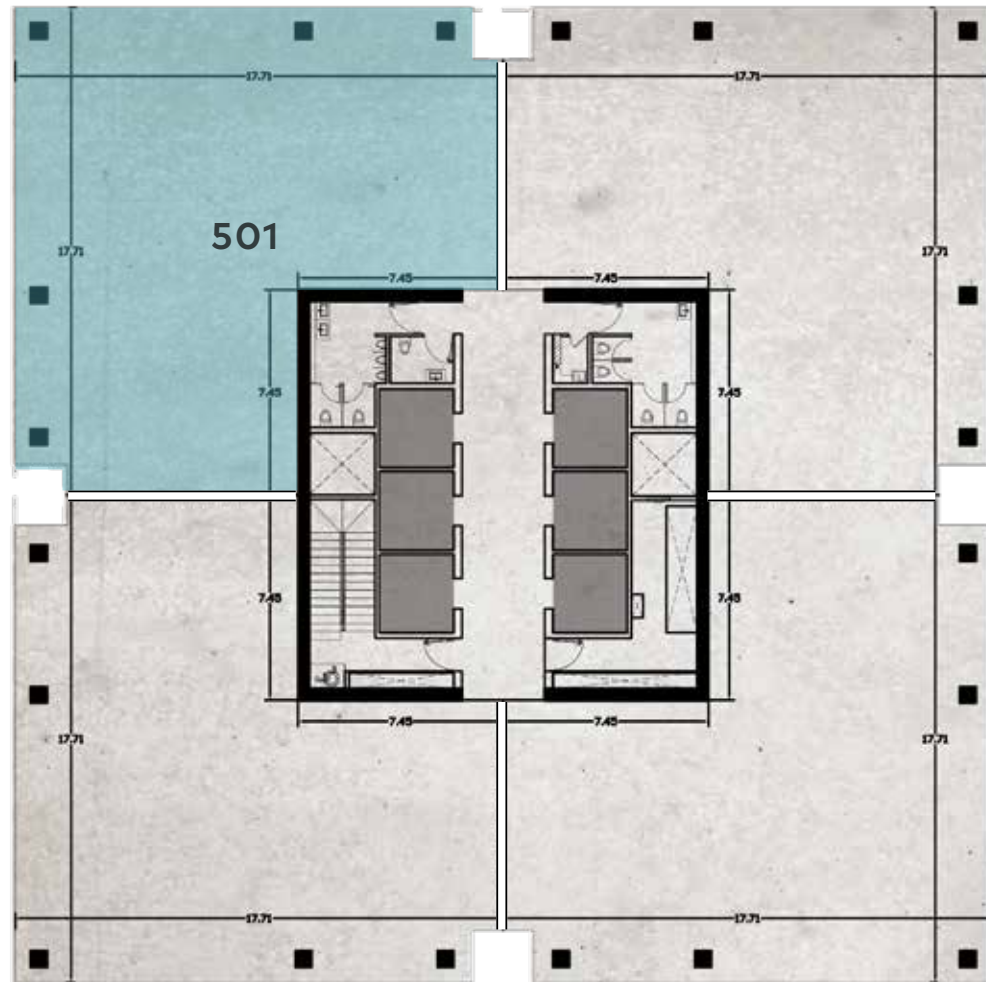

DESGLOSE DE ÁREAS

Oficina	253.94 m ²
Sanitarios	9.27 m ²
Área Común (Lobby)	11.80 m ²
Área Total	275.01 m ²



CENTRAL 200

UNIDAD

502

NIVEL

05

ÁREA

275 M²

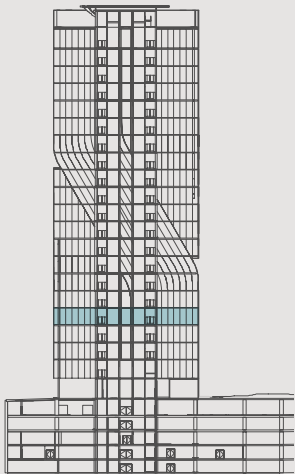

CALLE DEL COMERCIO

AVENIDA DE LA INDUSTRIA

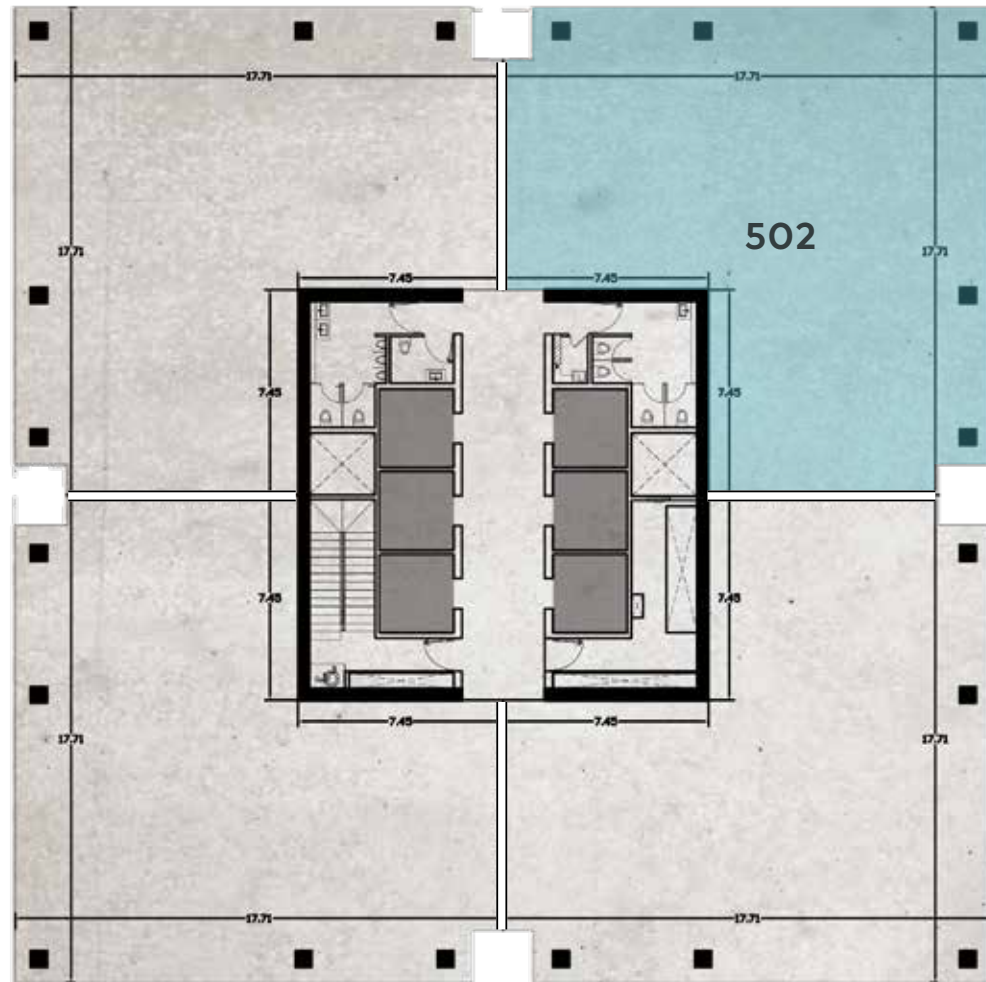

DESGLOSE DE ÁREAS

Oficina	253.94 m ²
Sanitarios	9.27 m ²
Área Común (Lobby)	11.80 m ²
Área Total	275.01 m ²



CENTRAL 200

UNIDAD

503

NIVEL

05

ÁREA

275 M²

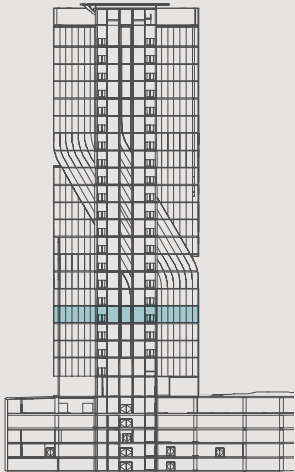

CALLE DEL COMERCIO

AVENIDA DE LA INDUSTRIA

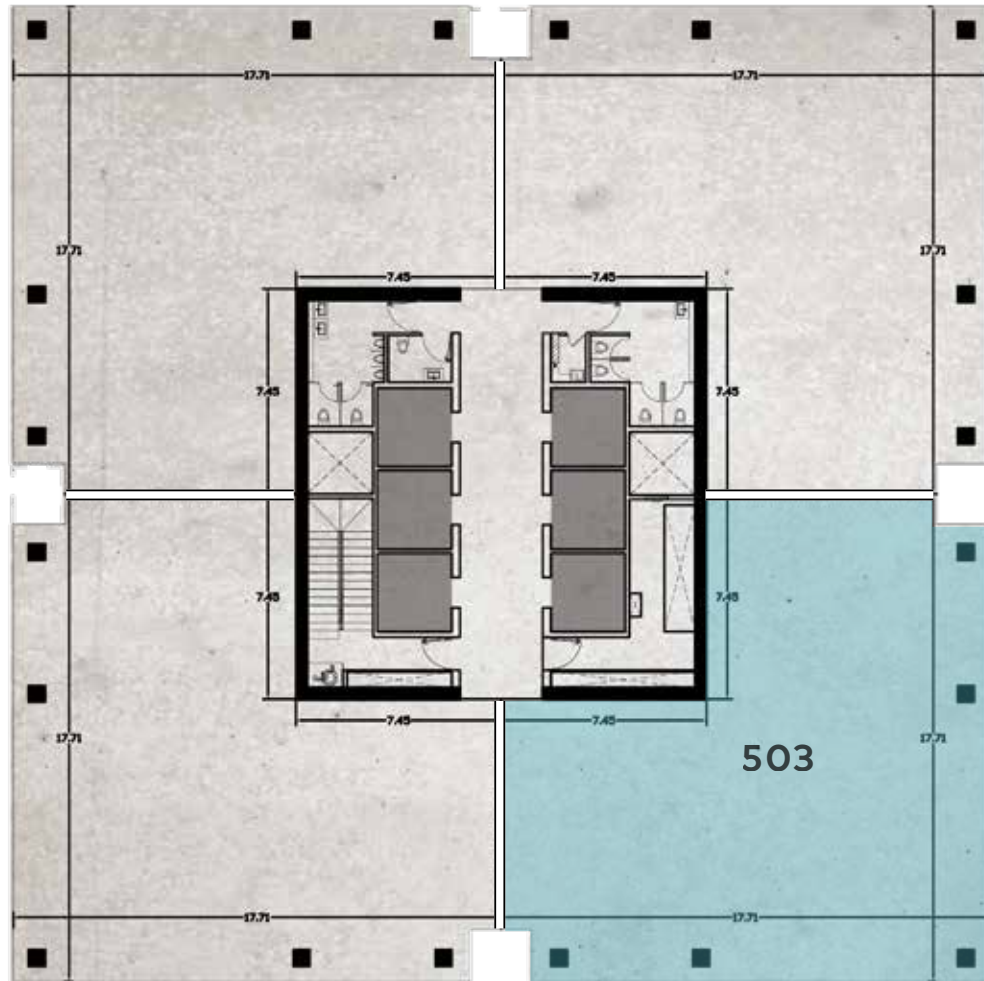

DESGLOSE DE ÁREAS

Oficina	253.94 m ²
Sanitarios	9.27 m ²
Área Común (Lobby)	11.80 m ²
Área Total	275.01 m ²



CENTRAL 200

UNIDAD

504

NIVEL

05

ÁREA

275 M²

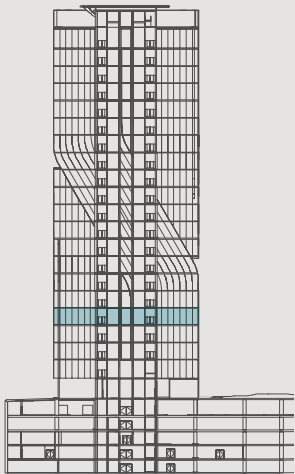

CALLE DEL COMERCIO

AVENIDA DE LA INDUSTRIA

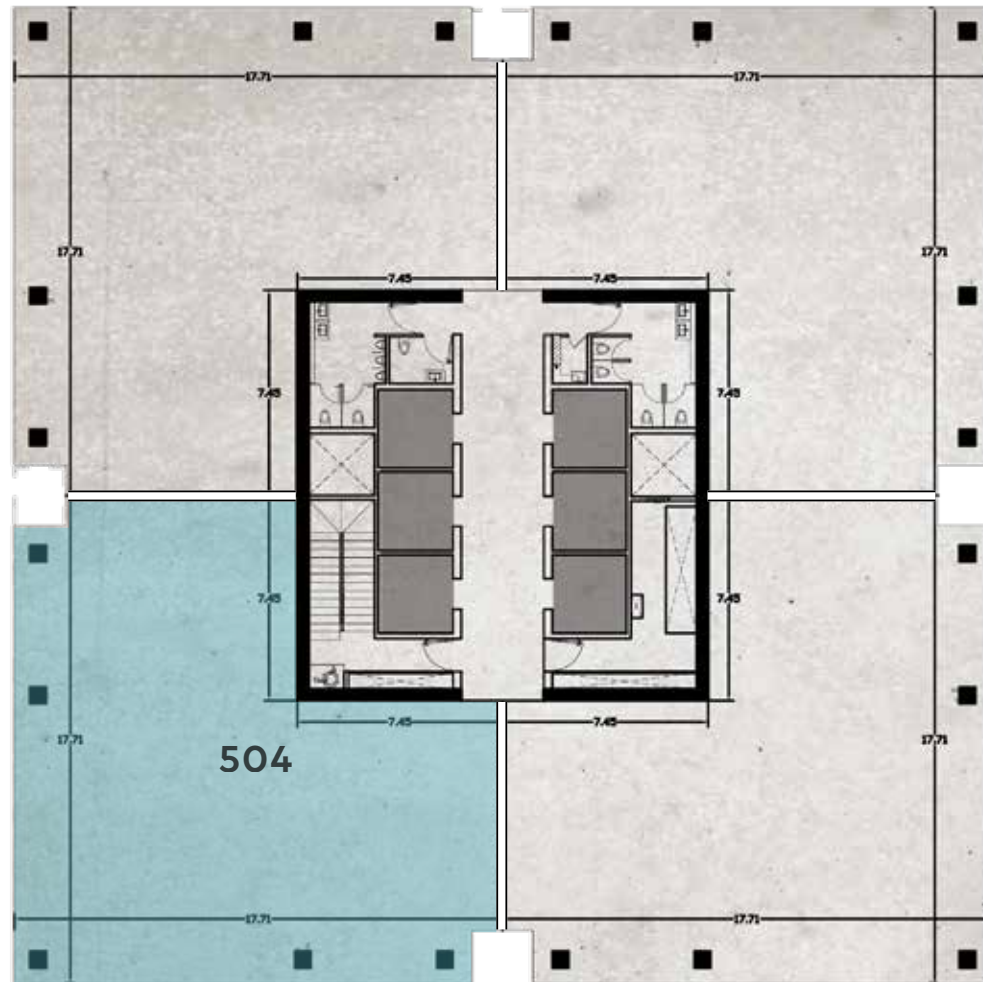

DESGLOSE DE ÁREAS

Oficina	253.94 m ²
Sanitarios	9.27 m ²
Área Común (Lobby)	11.80 m ²
Área Total	275.01 m ²



CENTRAL 200

UNIDAD

601

NIVEL

06

ÁREA

275 M²

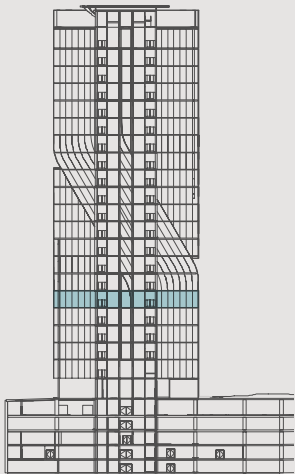

CALLE DEL COMERCIO

AVENIDA DE LA INDUSTRIA

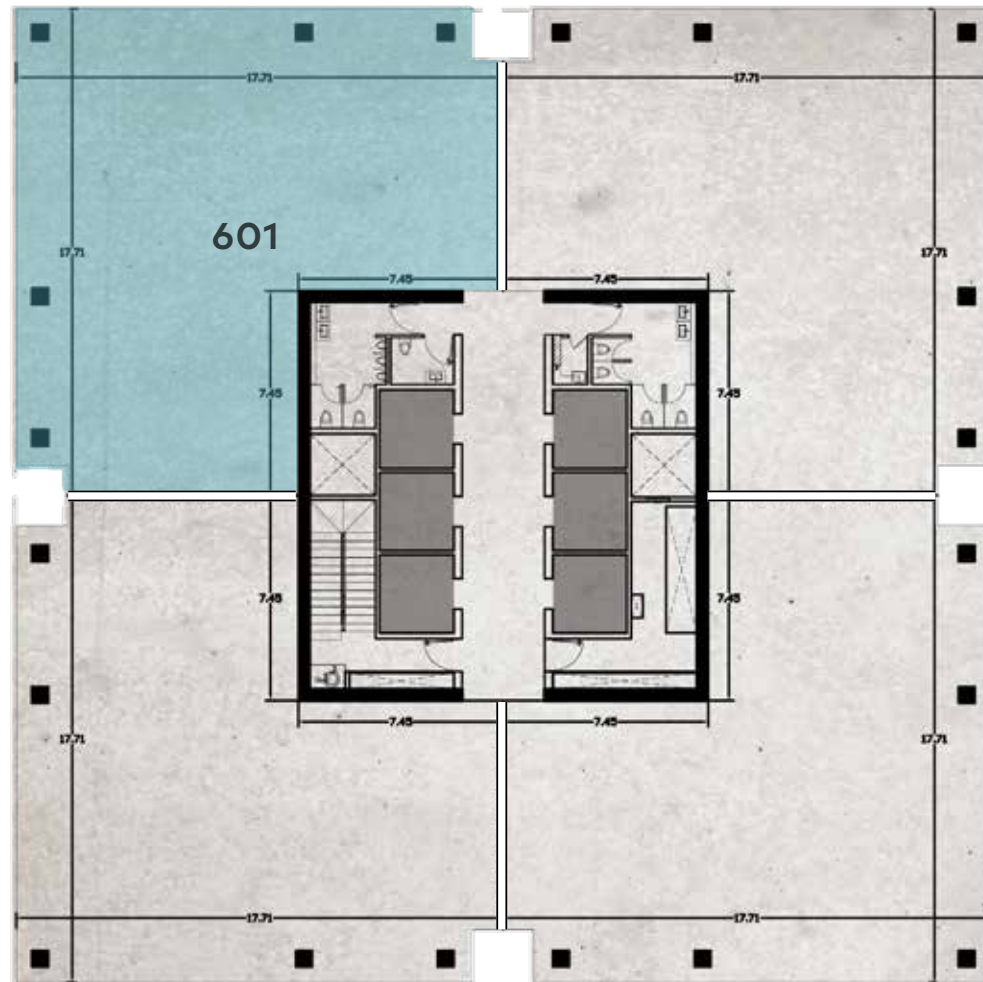

DESGLOSE DE ÁREAS

Oficina	253.94 m ²
Sanitarios	9.27 m ²
Área Común (Lobby)	11.80 m ²
Área Total	275.01 m ²



CENTRAL 200

UNIDAD

602

NIVEL

06

ÁREA

275 M²

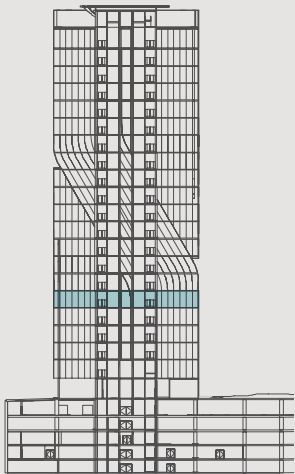

CALLE DEL COMERCIO

AVENIDA DE LA INDUSTRIA

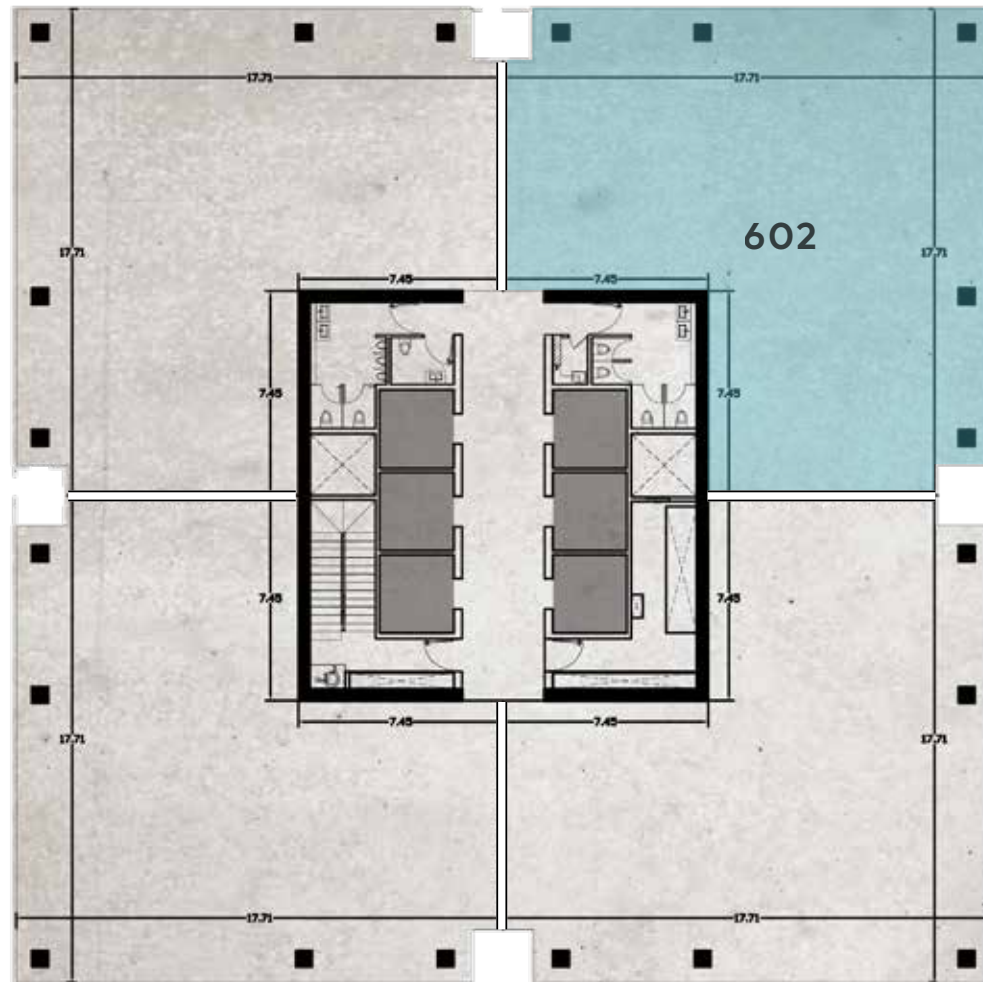

DESGLOSE DE ÁREAS

Oficina	253.94 m ²
Sanitarios	9.27 m ²
Área Común (Lobby)	11.80 m ²
Área Total	275.01 m ²



CENTRAL 200

UNIDAD

603

NIVEL

06

ÁREA

275 M²

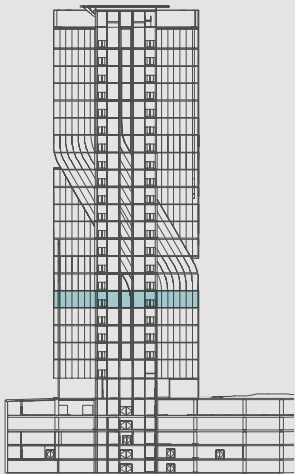

CALLE DEL COMERCIO

AVENIDA DE LA INDUSTRIA

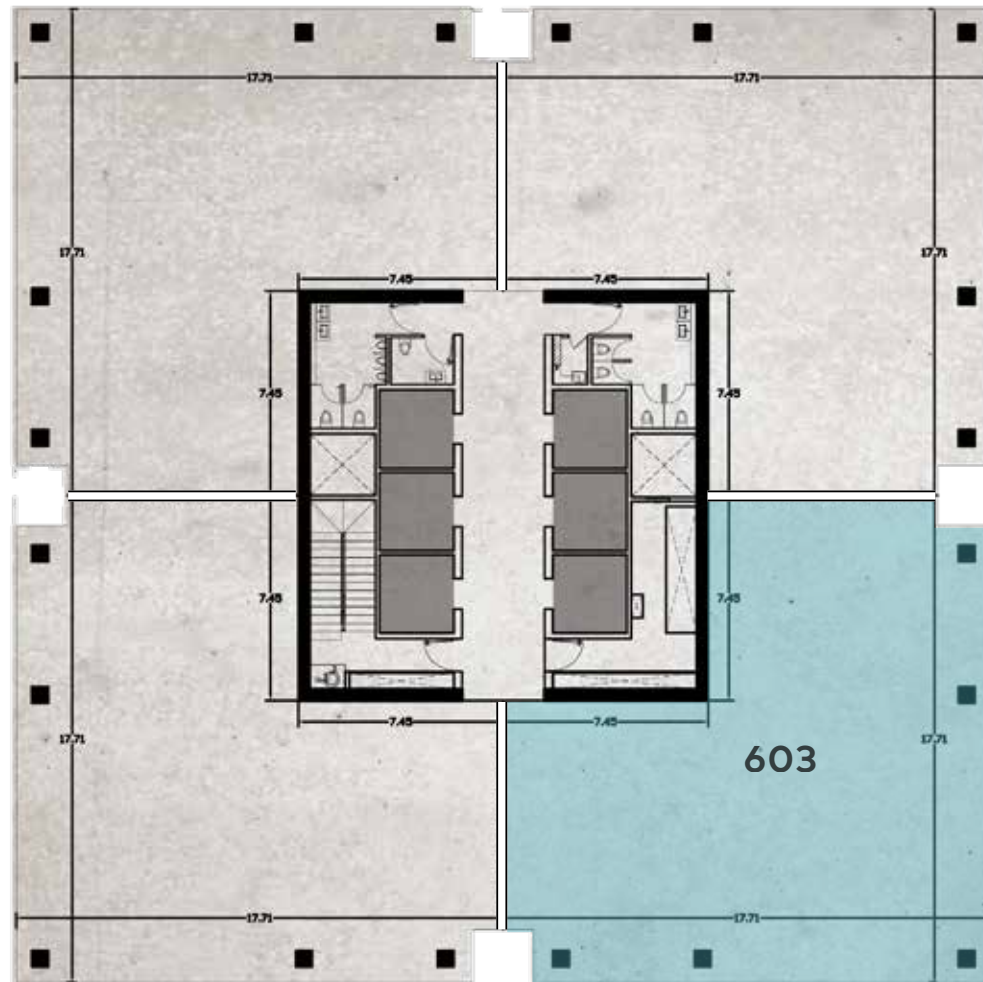

DESGLOSE DE ÁREAS

Oficina	253.94 m ²
Sanitarios	9.27 m ²
Área Común (Lobby)	11.80 m ²
Área Total	275.01 m ²



CENTRAL 200

UNIDAD

604

NIVEL

06

ÁREA

275 M²

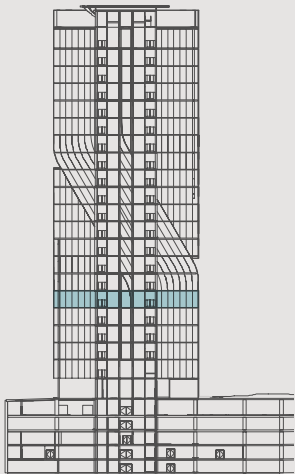

CALLE DEL COMERCIO

AVENIDA DE LA INDUSTRIA

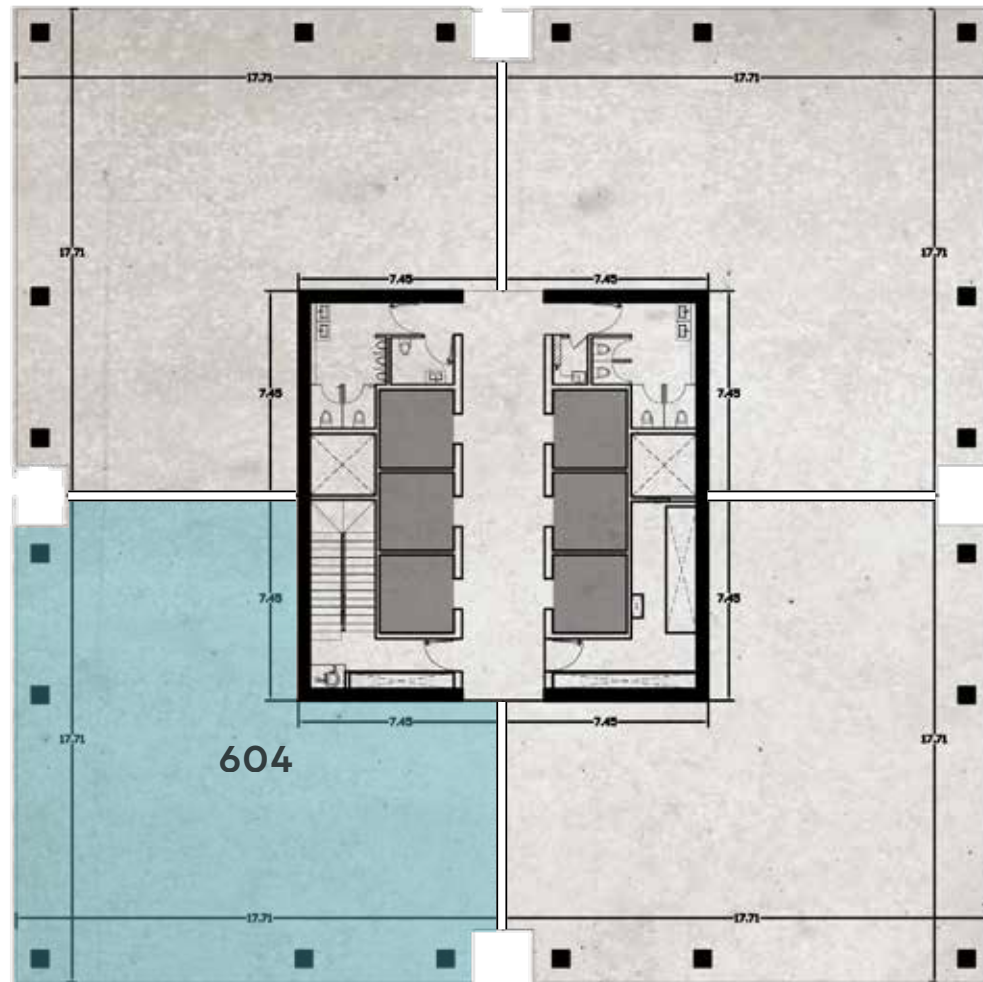

DESGLOSE DE ÁREAS

Oficina	253.94 m ²
Sanitarios	9.27 m ²
Área Común (Lobby)	11.80 m ²
Área Total	275.01 m ²



CENTRAL 200

UNIDAD

701

NIVEL

07

ÁREA

275.4 M²

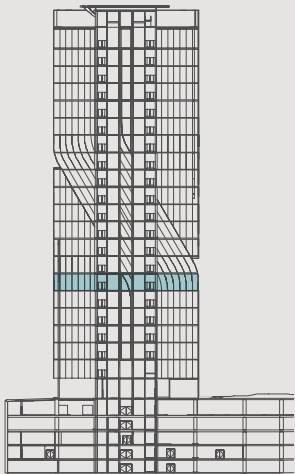

CALLE DEL COMERCIO

AVENIDA DE LA INDUSTRIA

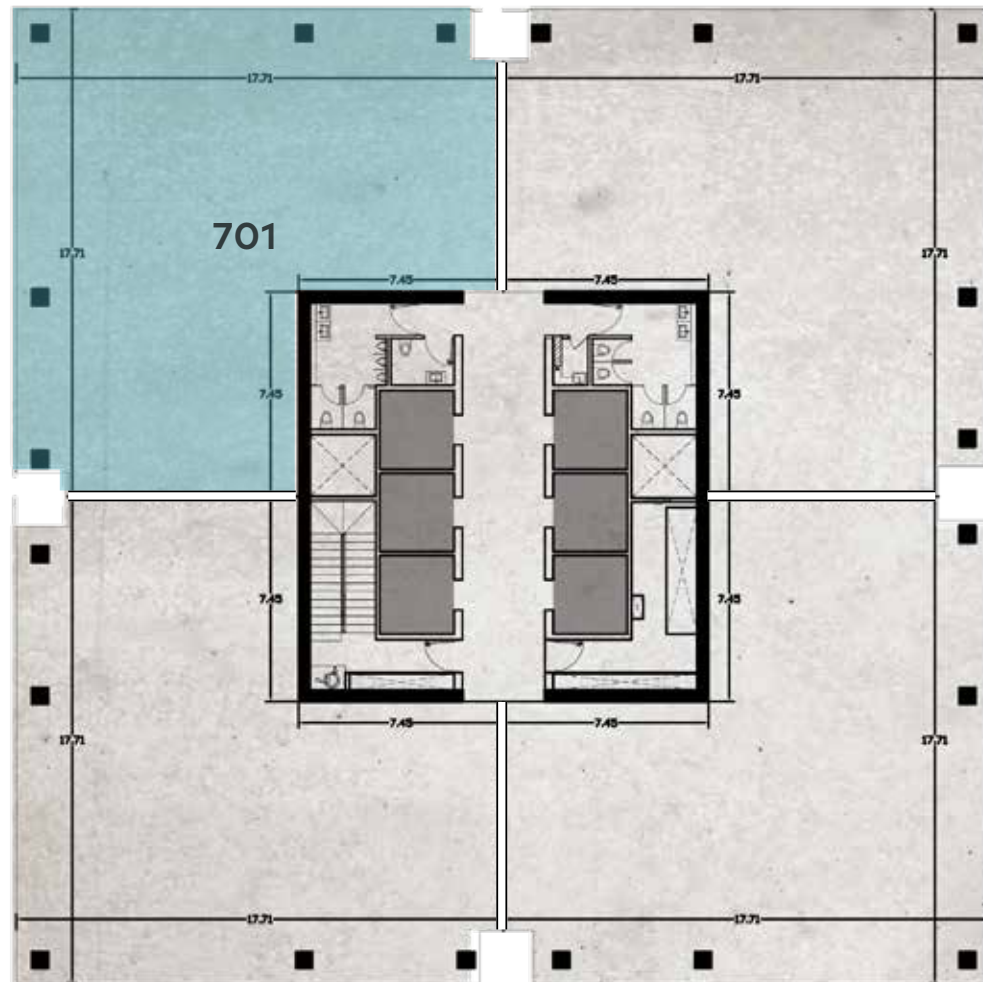

DESGLOSE DE ÁREAS

Oficina	254.37 m ²
Sanitarios	9.27 m ²
Área Común (Lobby)	11.80 m ²
Área Total	275.44 m ²



CENTRAL 200

UNIDAD

702

NIVEL

07

ÁREA

275.4 M²

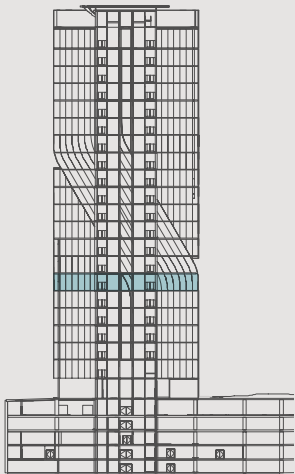

CALLE DEL COMERCIO

AVENIDA DE LA INDUSTRIA

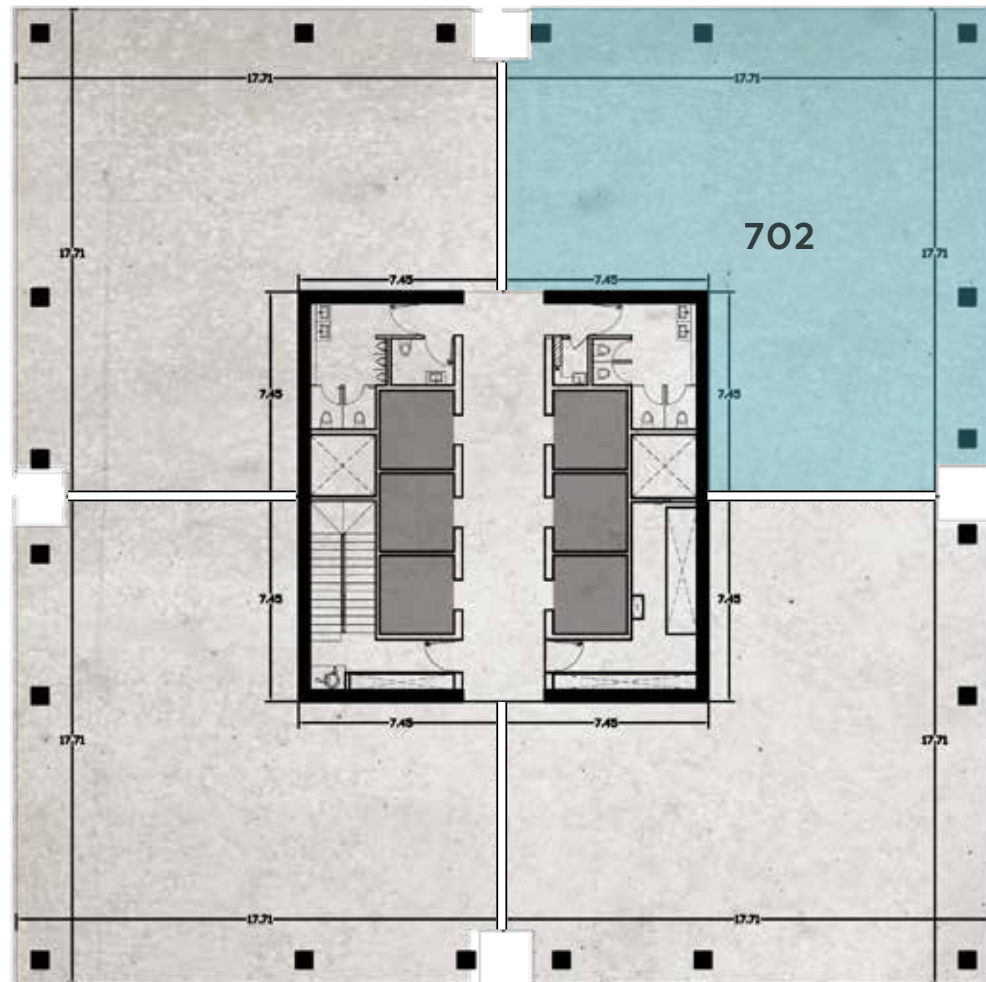

DESGLOSE DE ÁREAS

Oficina	254.37 m ²
Sanitarios	9.27 m ²
Área Común (Lobby)	11.80 m ²
Área Total	275.44 m ²



CENTRAL 200

UNIDAD

703

NIVEL

07

ÁREA

275.4 M²

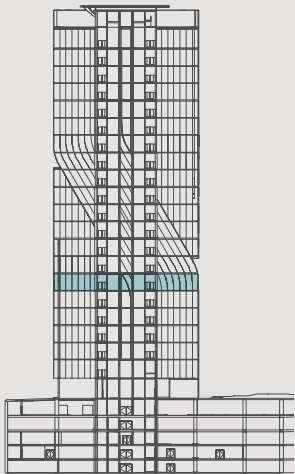

CALLE DEL COMERCIO

AVENIDA DE LA INDUSTRIA

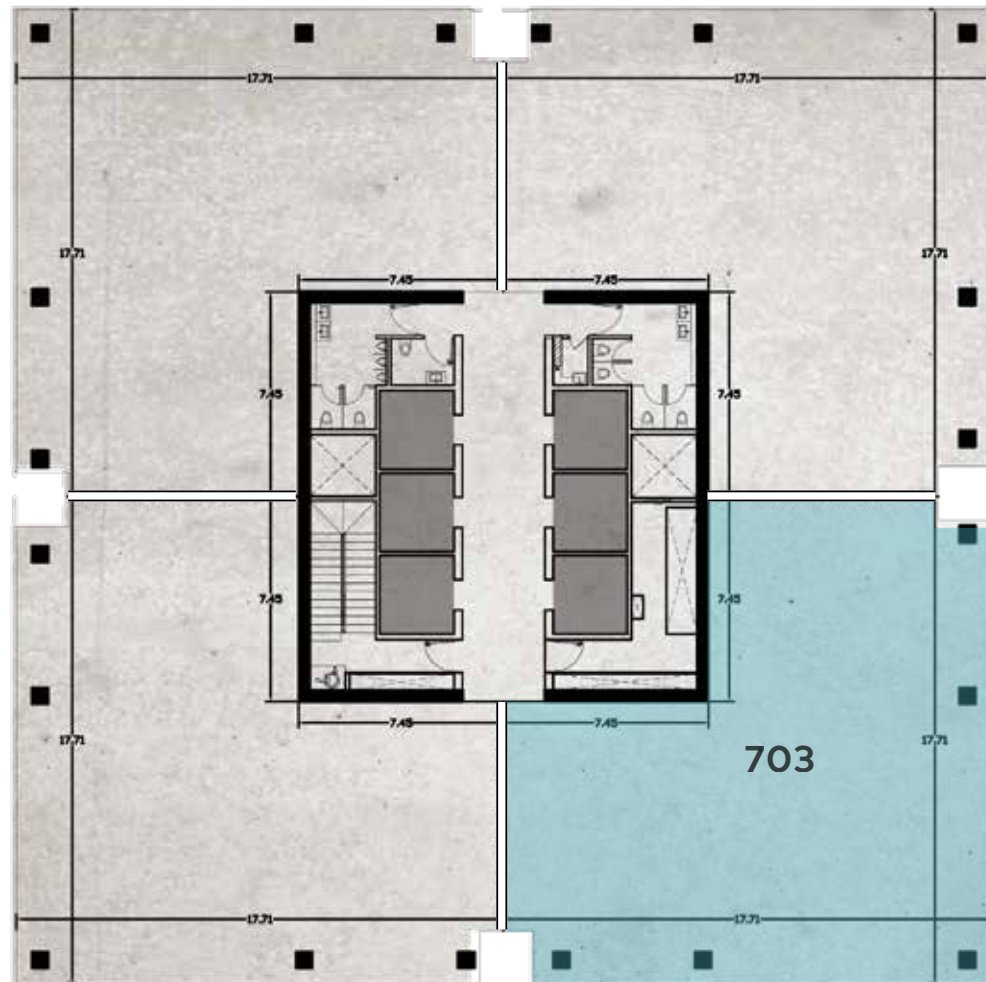

DESGLOSE DE ÁREAS

Oficina	254.37 m ²
Sanitarios	9.27 m ²
Área Común (Lobby)	11.80 m ²
Área Total	275.44 m ²



CENTRAL 200

UNIDAD

704

NIVEL

07

ÁREA

275.4 M²

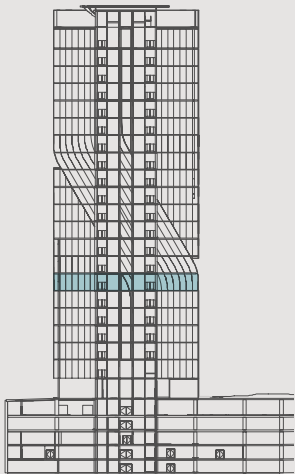

CALLE DEL COMERCIO

AVENIDA DE LA INDUSTRIA

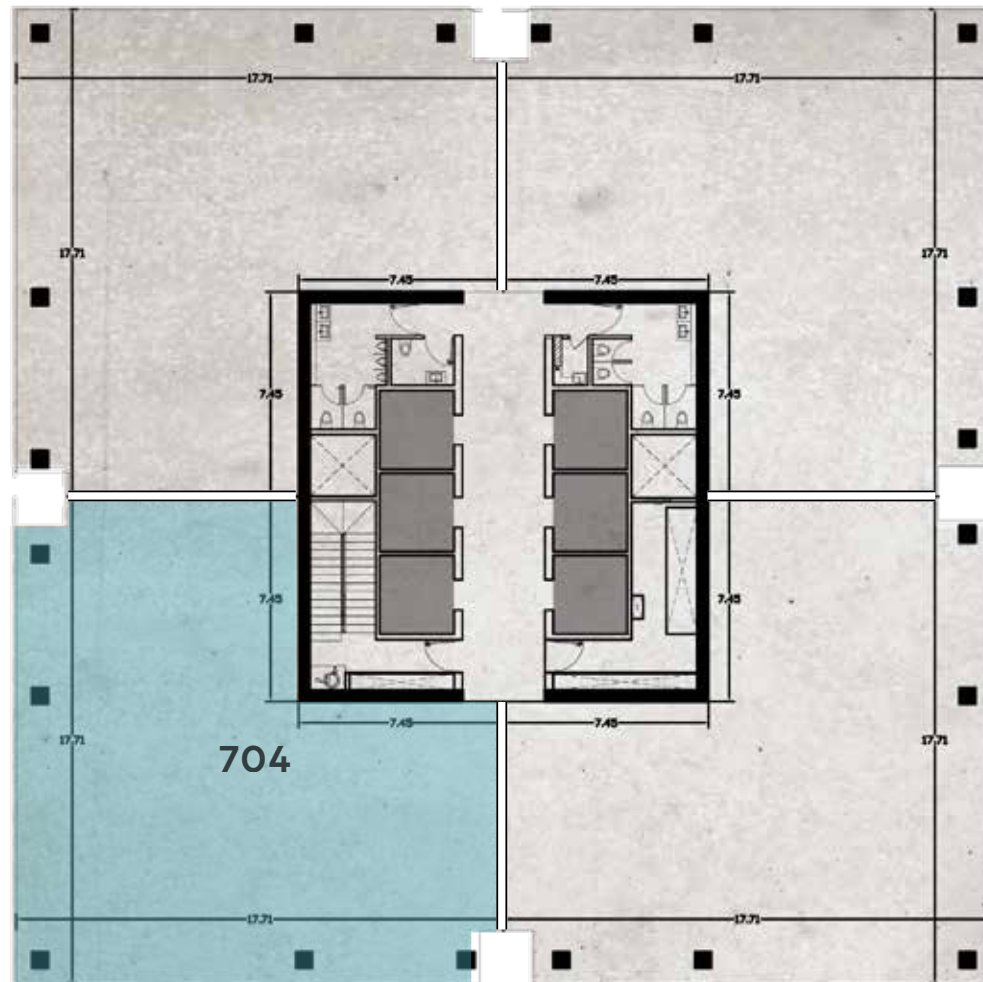

DESGLOSE DE ÁREAS

Oficina	254.37 m ²
Sanitarios	9.27 m ²
Área Común (Lobby)	11.80 m ²
Área Total	275.44 m ²



CENTRAL 200

UNIDAD

801

NIVEL

08

ÁREA

273 M²

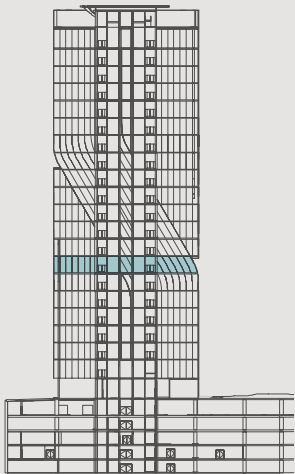

CALLE DEL COMERCIO

AVENIDA DE LA INDUSTRIA

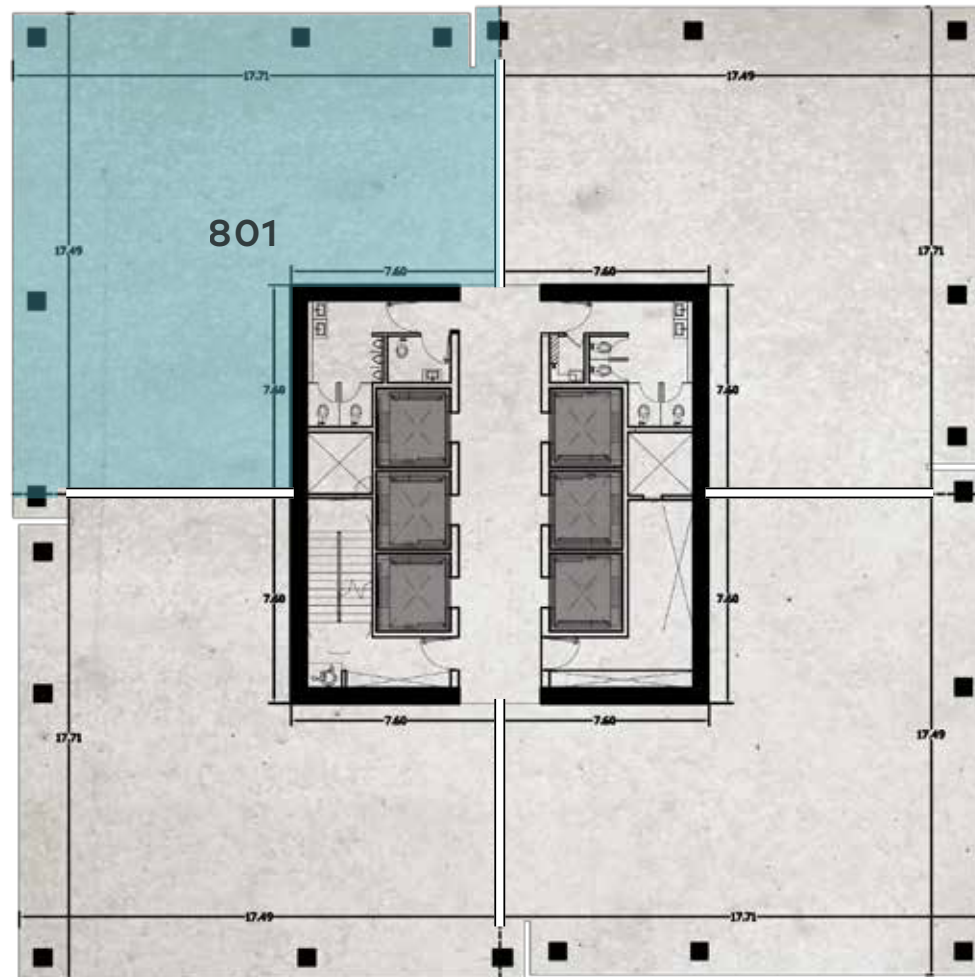

DESGLOSE DE ÁREAS

Oficina	251.68 m ²
Sanitarios	9.27 m ²
Área Común (Lobby)	12.03 m ²
Área Total	272.98 m ²



CENTRAL 200

UNIDAD

802

NIVEL

08

ÁREA

273 M²

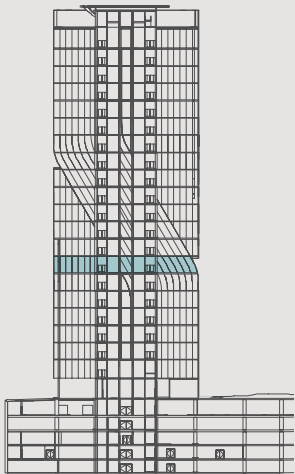

CALLE DEL COMERCIO

AVENIDA DE LA INDUSTRIA

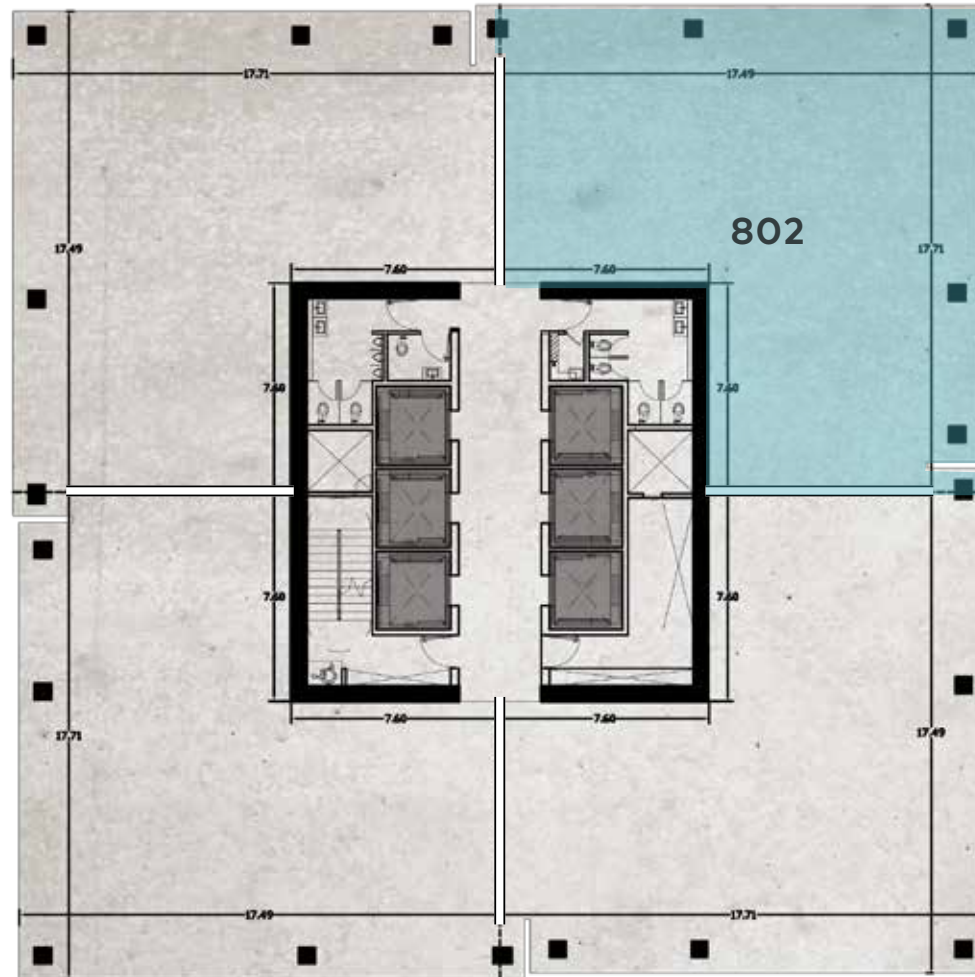

DESGLOSE DE ÁREAS

Oficina	251.68 m ²
Sanitarios	9.27 m ²
Área Común (Lobby)	12.03 m ²
Área Total	272.98 m ²



CENTRAL 200

UNIDAD

803

NIVEL

08

ÁREA

273 M²

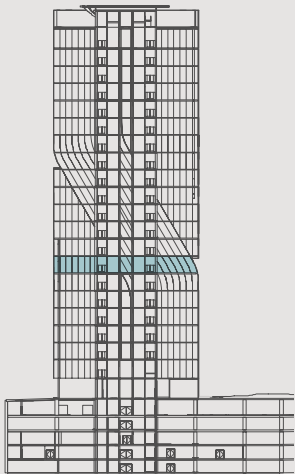

CALLE DEL COMERCIO

AVENIDA DE LA INDUSTRIA

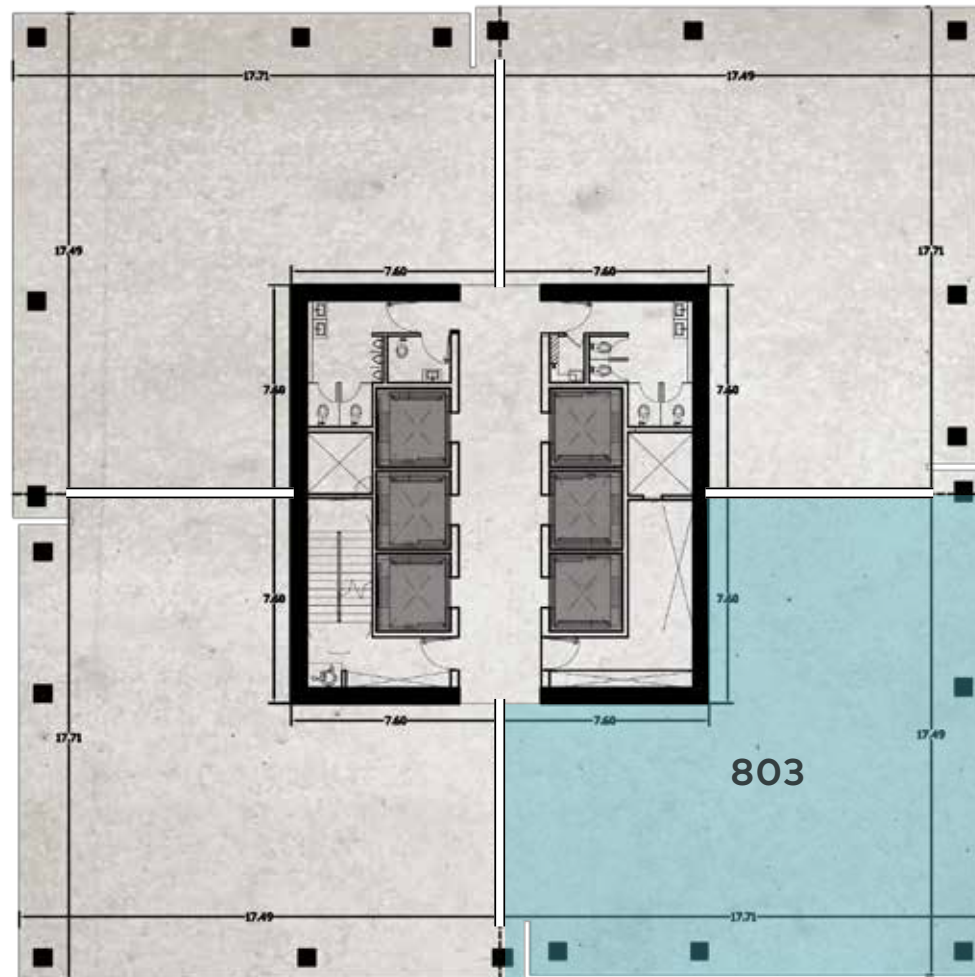

DESGLOSE DE ÁREAS

Oficina	251.68 m ²
Sanitarios	9.27 m ²
Área Común (Lobby)	12.03 m ²
Área Total	272.98 m ²



CENTRAL 200

UNIDAD

804

NIVEL

08

ÁREA

273 M²

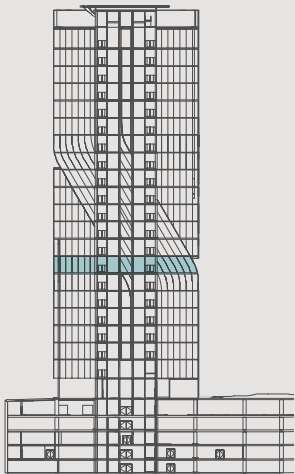

CALLE DEL COMERCIO

AVENIDA DE LA INDUSTRIA

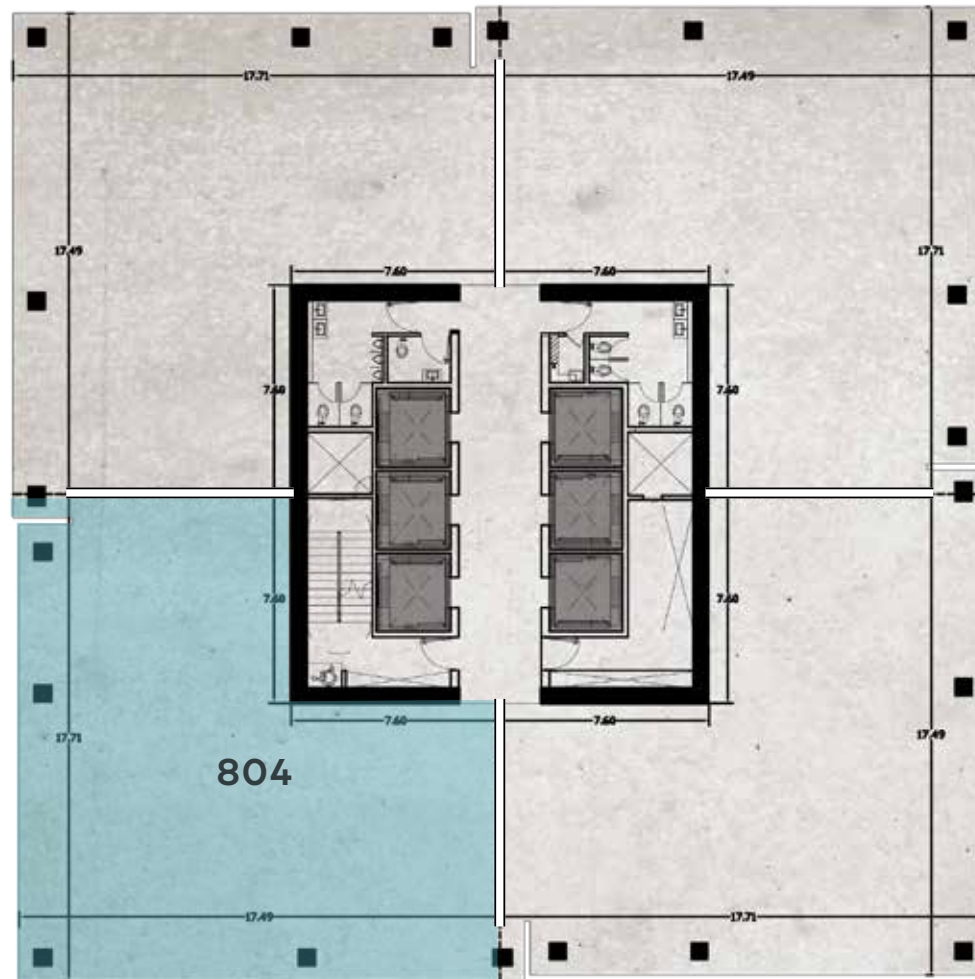

DESGLOSE DE ÁREAS

Oficina	251.68 m ²
Sanitarios	9.27 m ²
Área Común (Lobby)	12.03 m ²
Área Total	272.98 m ²



CENTRAL 200

UNIDAD

901

NIVEL

09

ÁREA

247.5 M²

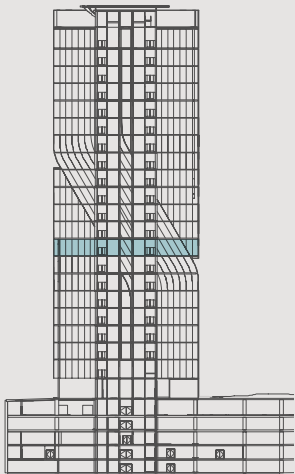

CALLE DEL COMERCIO

AVENIDA DE LA INDUSTRIA

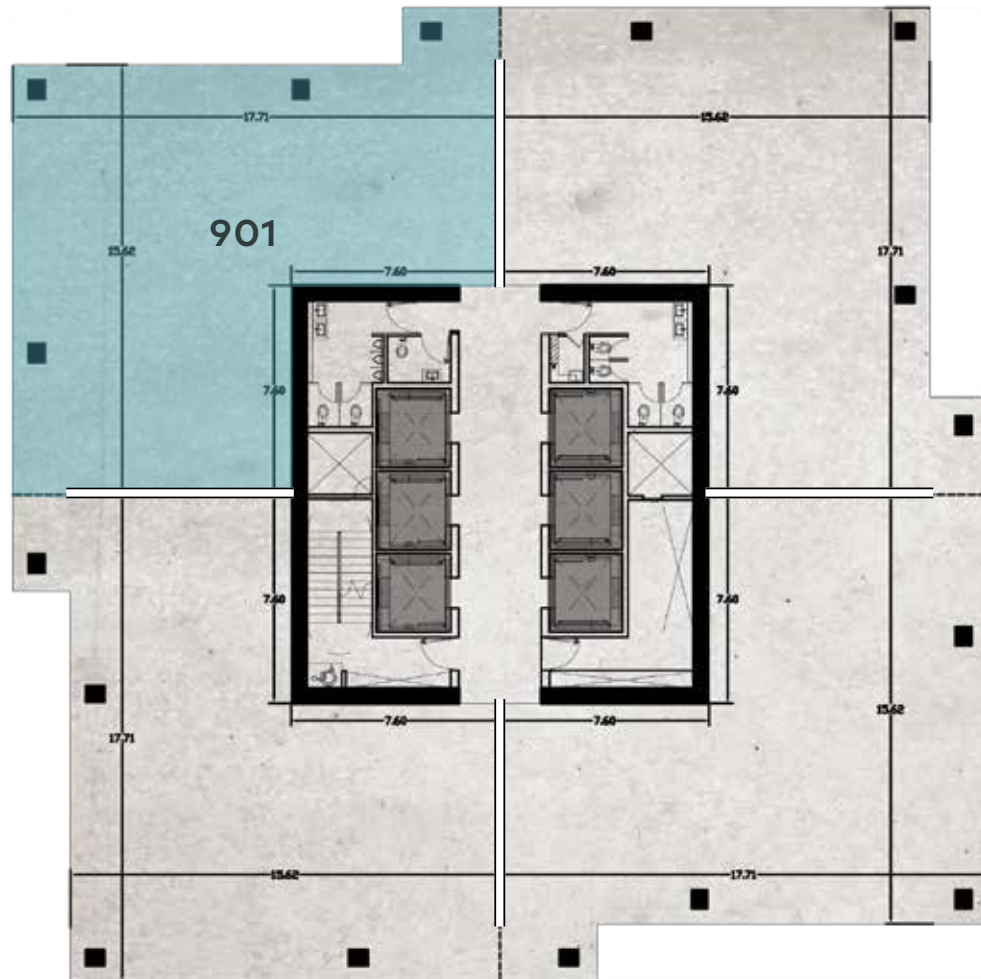

DESGLOSE DE ÁREAS

Oficina	226.26 m ²
Sanitarios	9.27 m ²
Área Común (Lobby)	12.03 m ²
Área Total	247.55 m ²



CENTRAL 200

UNIDAD

902

NIVEL

09

ÁREA

247.5 M²

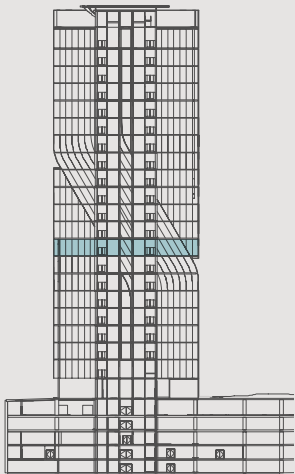

CALLE DEL COMERCIO

AVENIDA DE LA INDUSTRIA

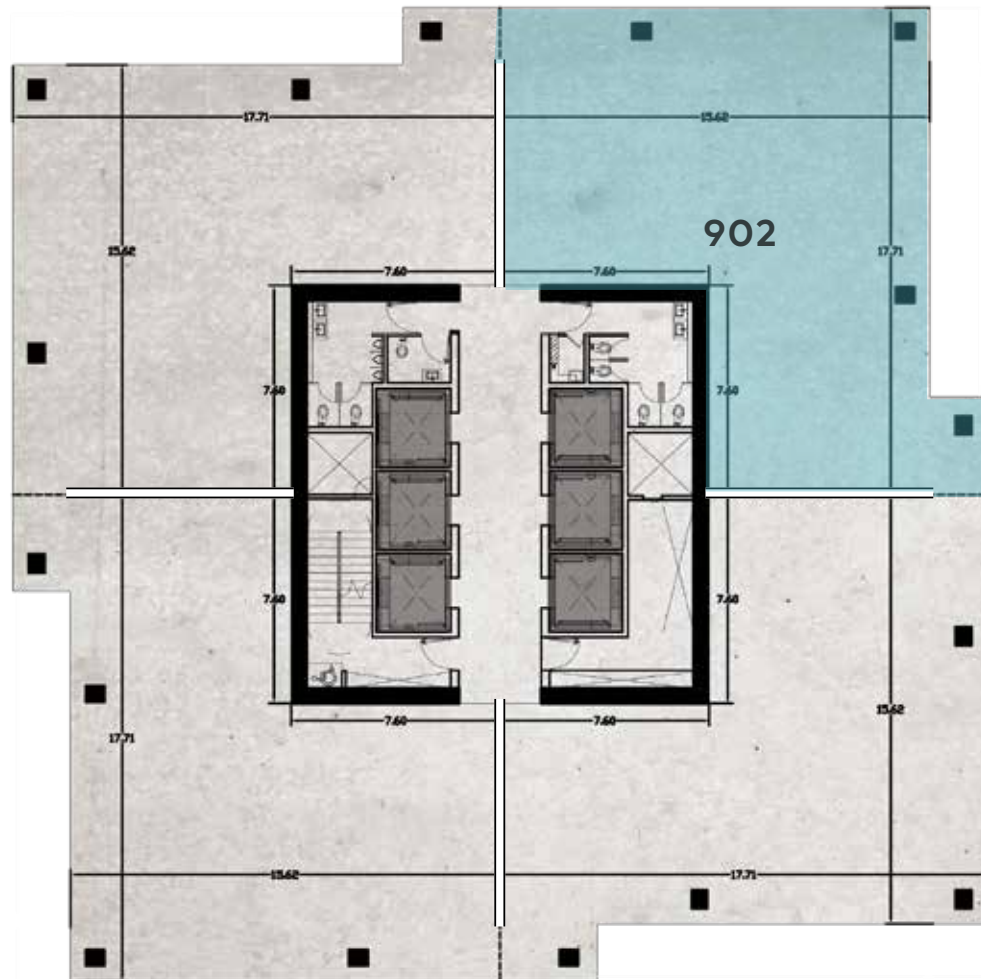

DESGLOSE DE ÁREAS

Oficina	226.26 m ²
Sanitarios	9.27 m ²
Área Común (Lobby)	12.03 m ²
Área Total	247.55 m ²



CENTRAL 200

UNIDAD

903

NIVEL

09

ÁREA

247.5 M²

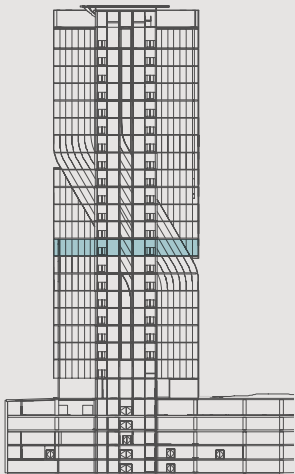

CALLE DEL COMERCIO

AVENIDA DE LA INDUSTRIA

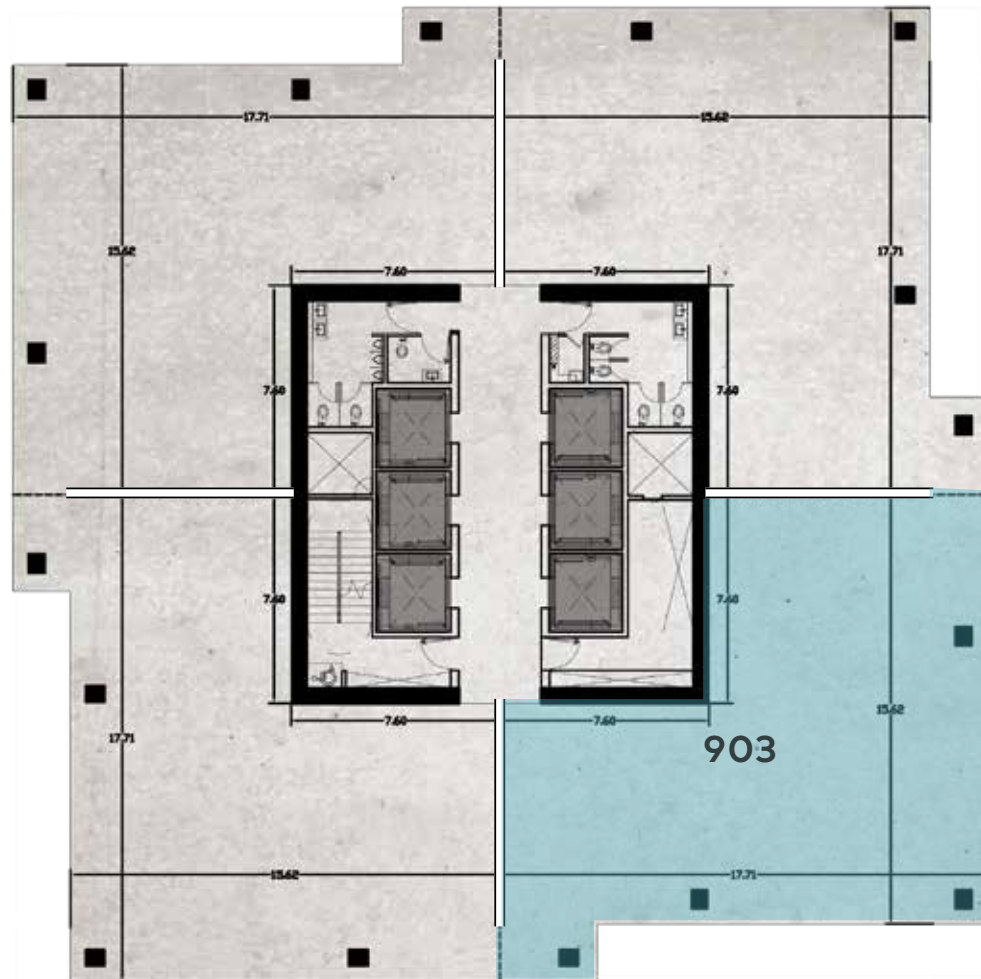

DESGLOSE DE ÁREAS

Oficina	226.26 m ²
Sanitarios	9.27 m ²
Área Común (Lobby)	12.03 m ²
Área Total	247.55 m ²



CENTRAL 200

UNIDAD

904

NIVEL

09

ÁREA

247.5 M²

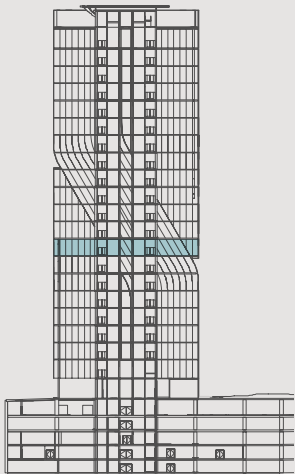

CALLE DEL COMERCIO

AVENIDA DE LA INDUSTRIA

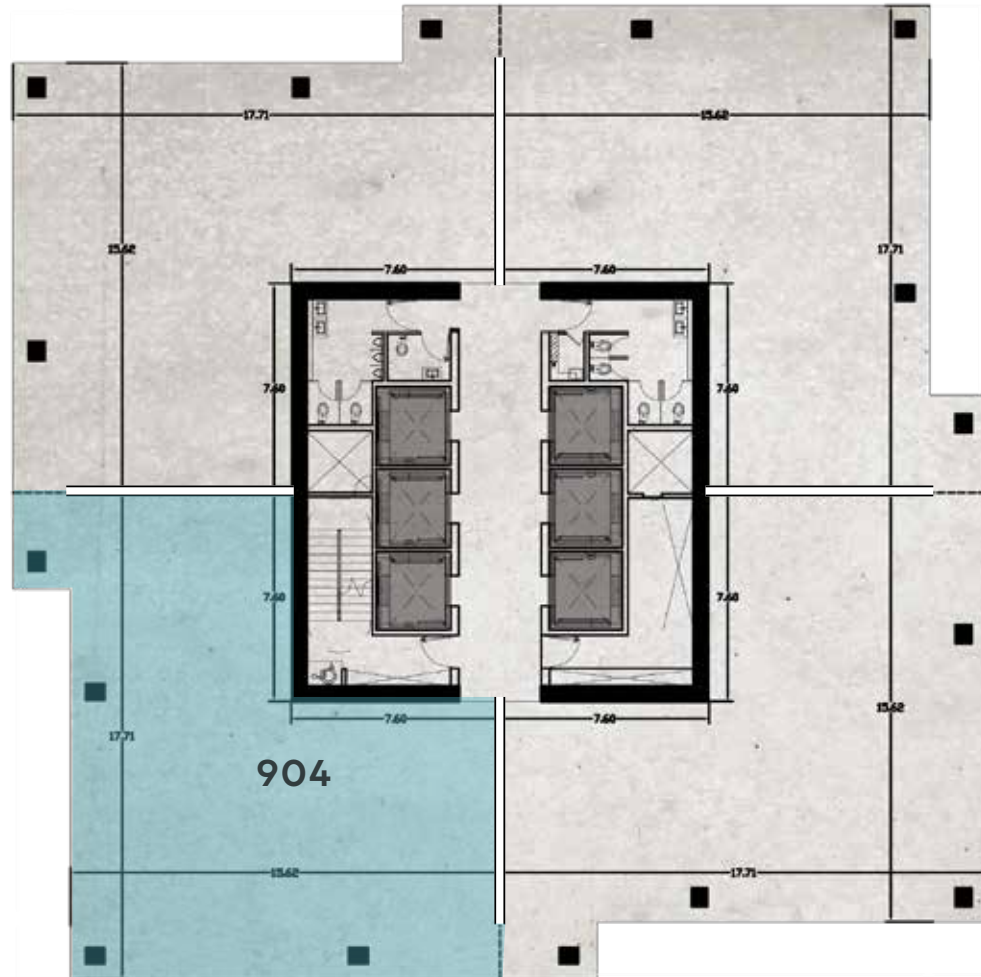

DESGLOSE DE ÁREAS

Oficina	226.26 m ²
Sanitarios	9.27 m ²
Área Común (Lobby)	12.03 m ²
Área Total	247.55 m ²



CENTRAL 200

UNIDAD

1001

NIVEL

10

ÁREA

224 M²

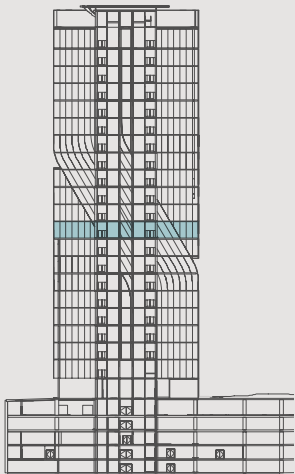

CALLE DEL COMERCIO

AVENIDA DE LA INDUSTRIA

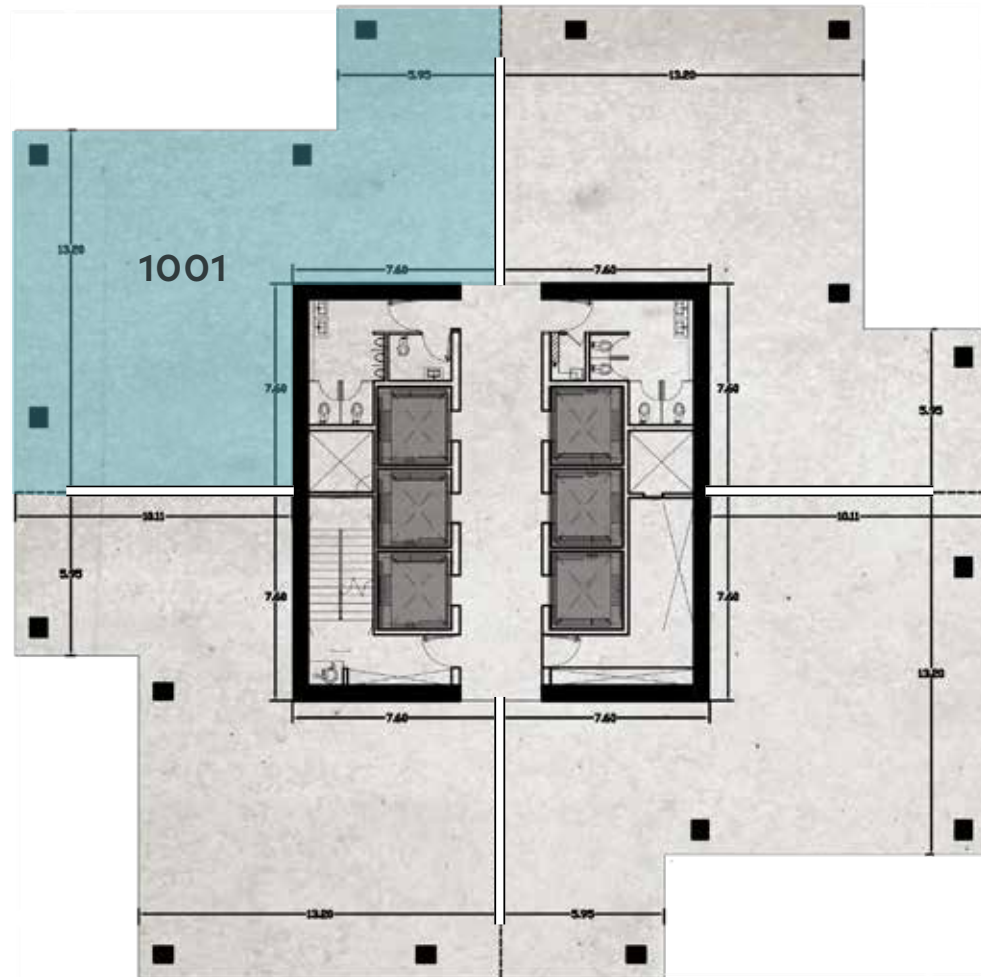

DESGLOSE DE ÁREAS

Oficina	202.85 m ²
Sanitarios	9.27 m ²
Área Común (Lobby)	12.03 m ²
Área Total	224.14 m ²



CENTRAL 200

UNIDAD

1002

NIVEL

10

ÁREA

224 M²

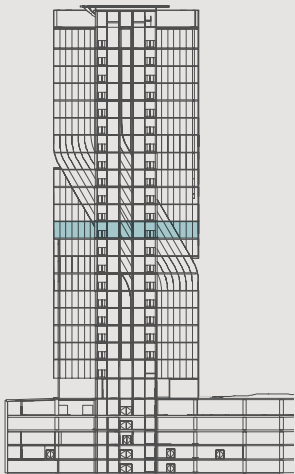

CALLE DEL COMERCIO

AVENIDA DE LA INDUSTRIA

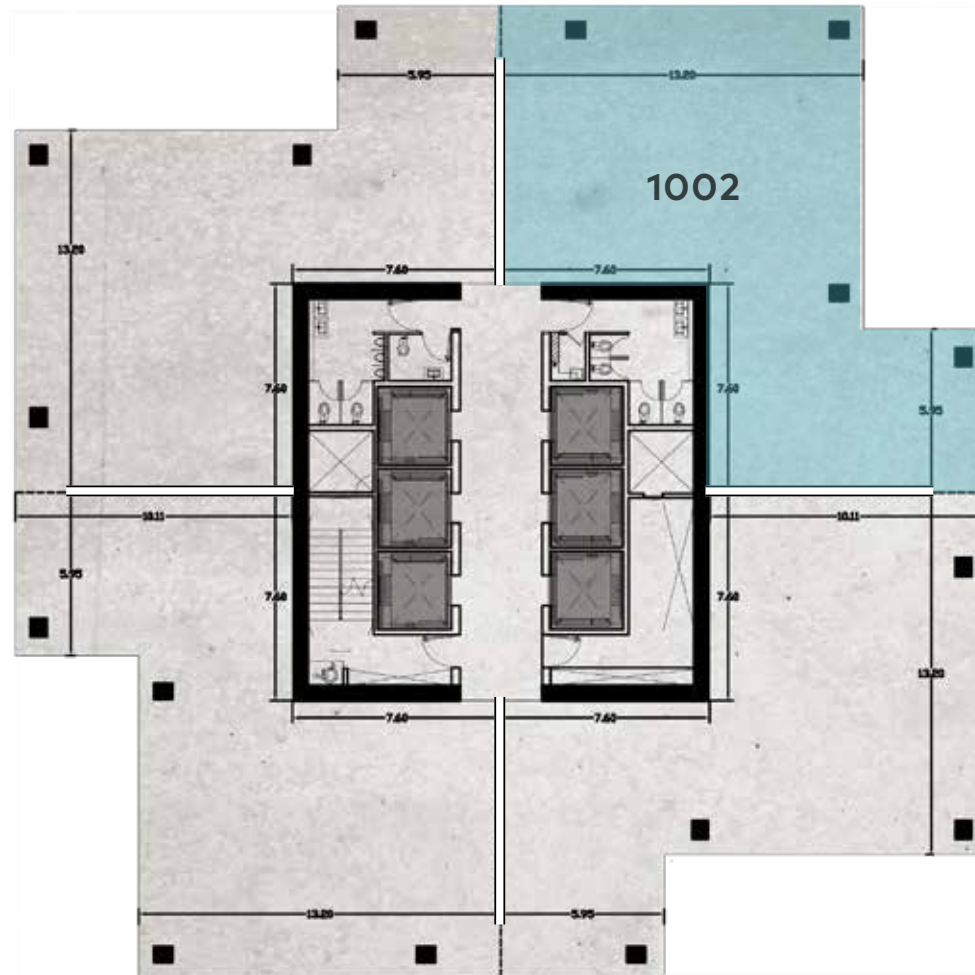

DESGLOSE DE ÁREAS

Oficina	202.85 m ²
Sanitarios	9.27 m ²
Área Común (Lobby)	12.03 m ²
Área Total	224.14 m ²



CENTRAL 200

UNIDAD

1003

NIVEL

10

ÁREA

224 M²

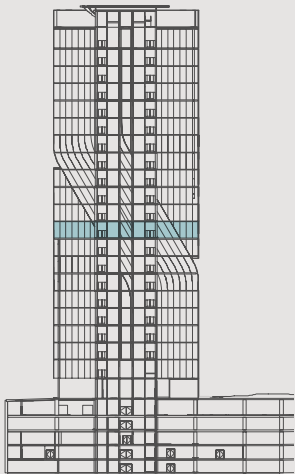

CALLE DEL COMERCIO

AVENIDA DE LA INDUSTRIA

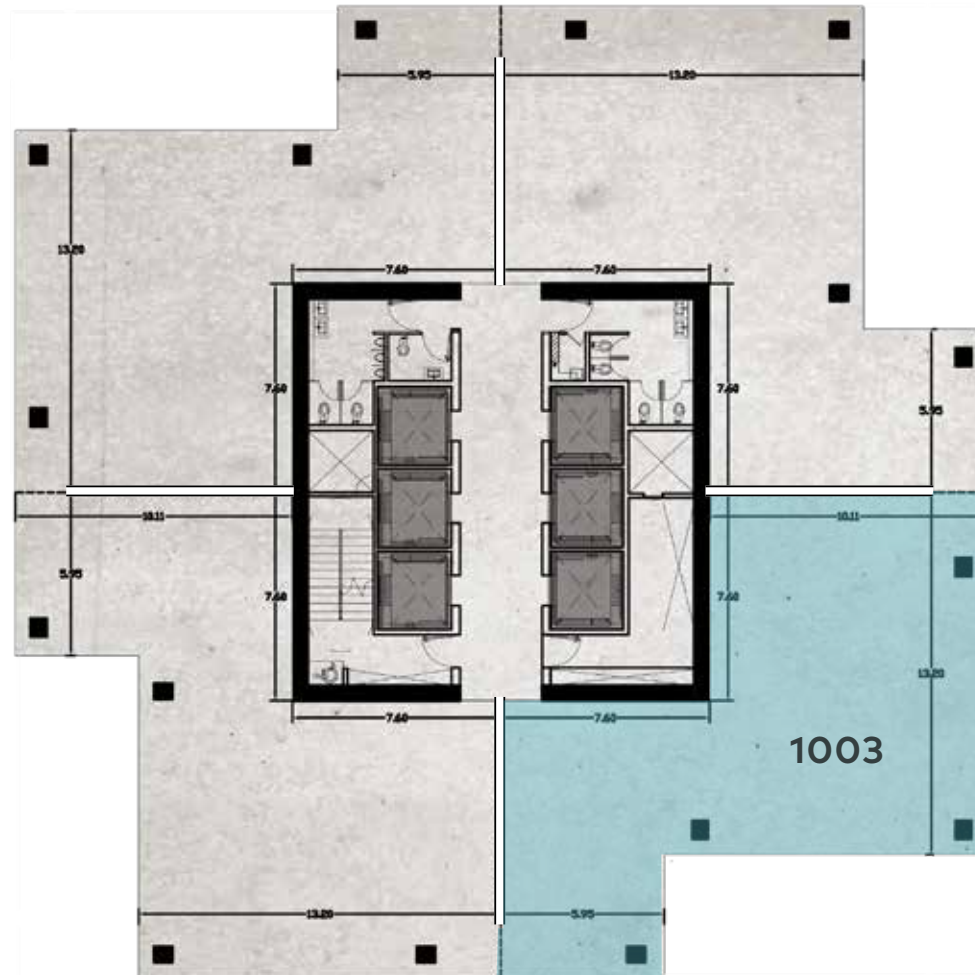

DESGLOSE DE ÁREAS

Oficina	202.85 m ²
Sanitarios	9.27 m ²
Área Común (Lobby)	12.03 m ²
Área Total	224.14 m ²



CENTRAL 200

UNIDAD

1004

NIVEL

10

ÁREA

224 M²

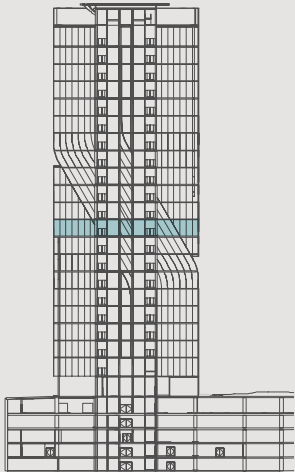

CALLE DEL COMERCIO

AVENIDA DE LA INDUSTRIA

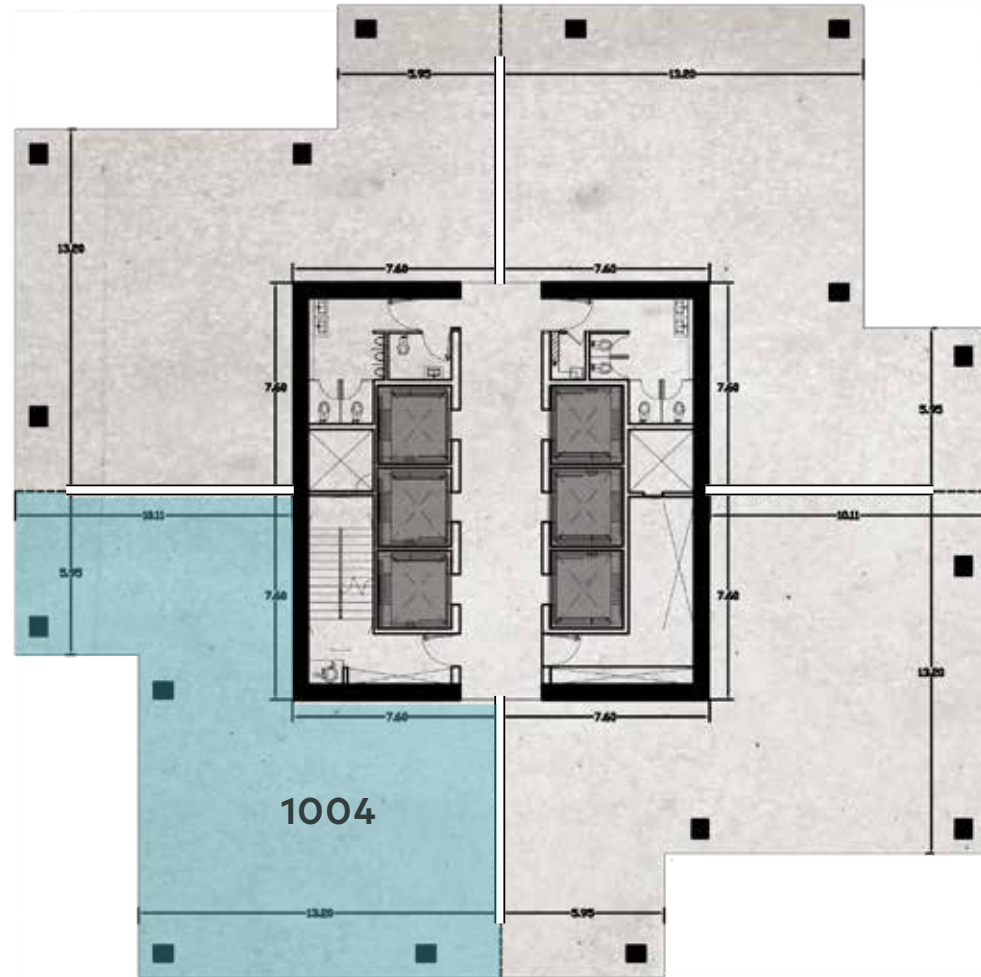

DESGLOSE DE ÁREAS

Oficina	202.85 m ²
Sanitarios	9.27 m ²
Área Común (Lobby)	12.03 m ²
Área Total	224.14 m ²



CENTRAL 200

UNIDAD

1101

NIVEL

11

ÁREA

212.5 M²

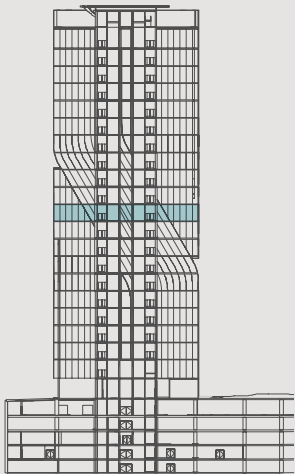

CALLE DEL COMERCIO

AVENIDA DE LA INDUSTRIA

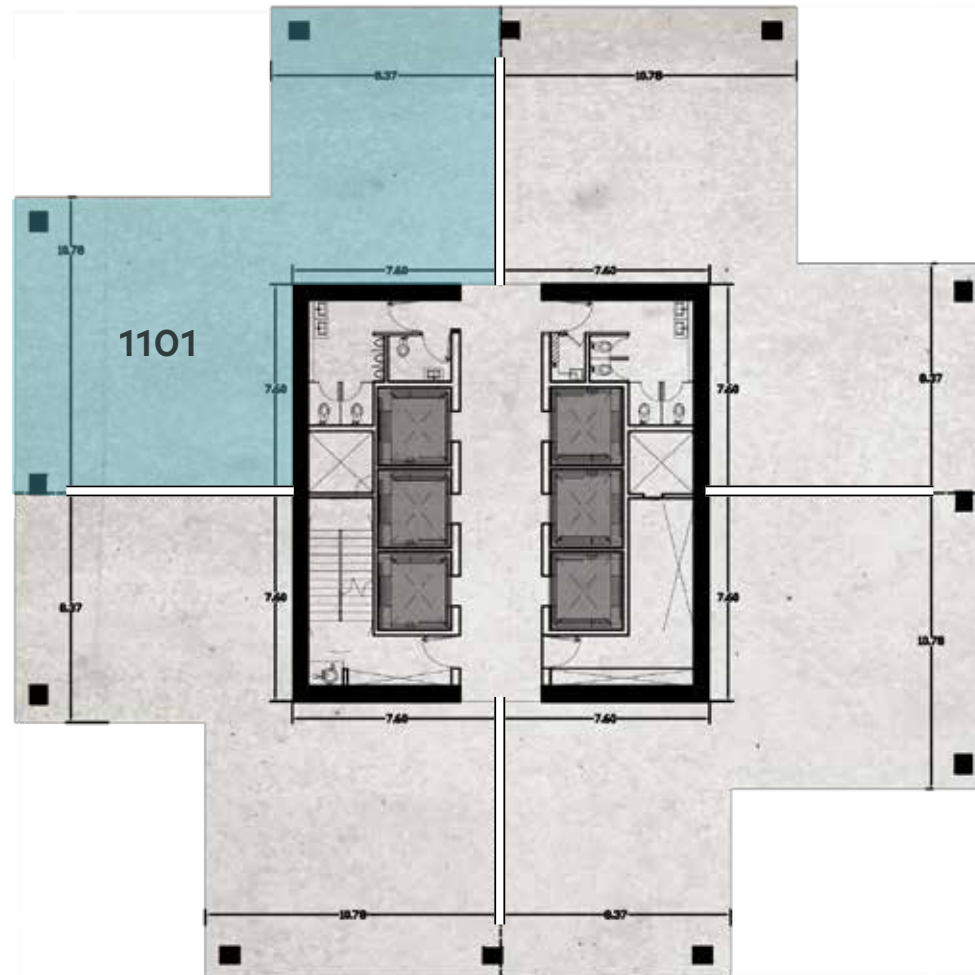

DESGLOSE DE ÁREAS

Oficina	191.15 m ²
Sanitarios	9.27 m ²
Área Común (Lobby)	12.03 m ²
Área Total	212.45 m ²



CENTRAL 200

UNIDAD

1102

NIVEL

11

ÁREA

212.5 M²

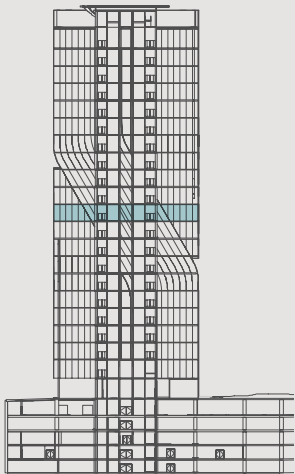

CALLE DEL COMERCIO

AVENIDA DE LA INDUSTRIA

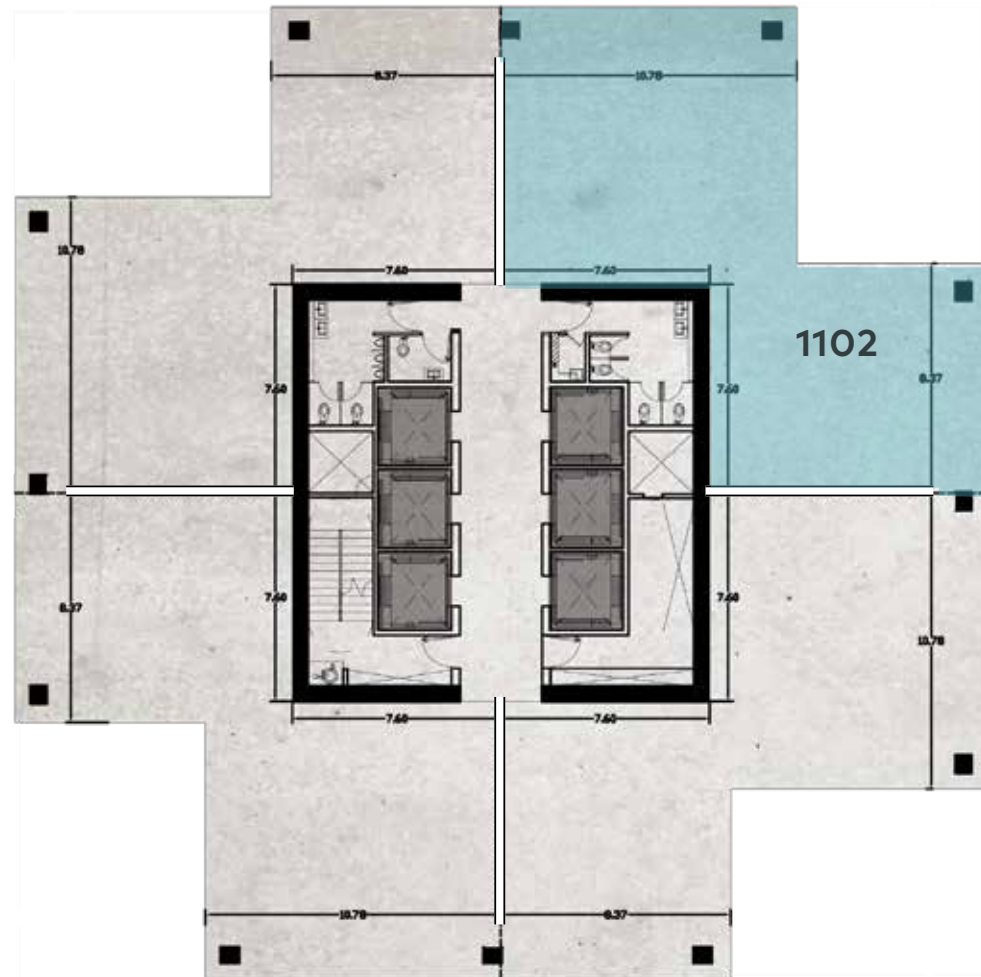

DESGLOSE DE ÁREAS

Oficina	191.15 m ²
Sanitarios	9.27 m ²
Área Común (Lobby)	12.03 m ²
Área Total	212.45 m ²



CENTRAL 200

UNIDAD

1103

NIVEL

11

ÁREA

212.5 M²

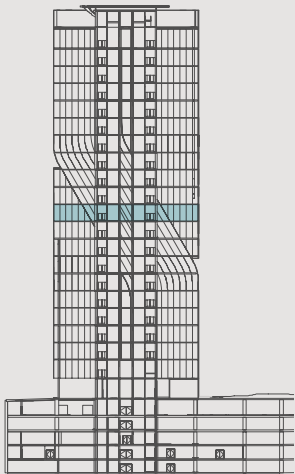

CALLE DEL COMERCIO

AVENIDA DE LA INDUSTRIA

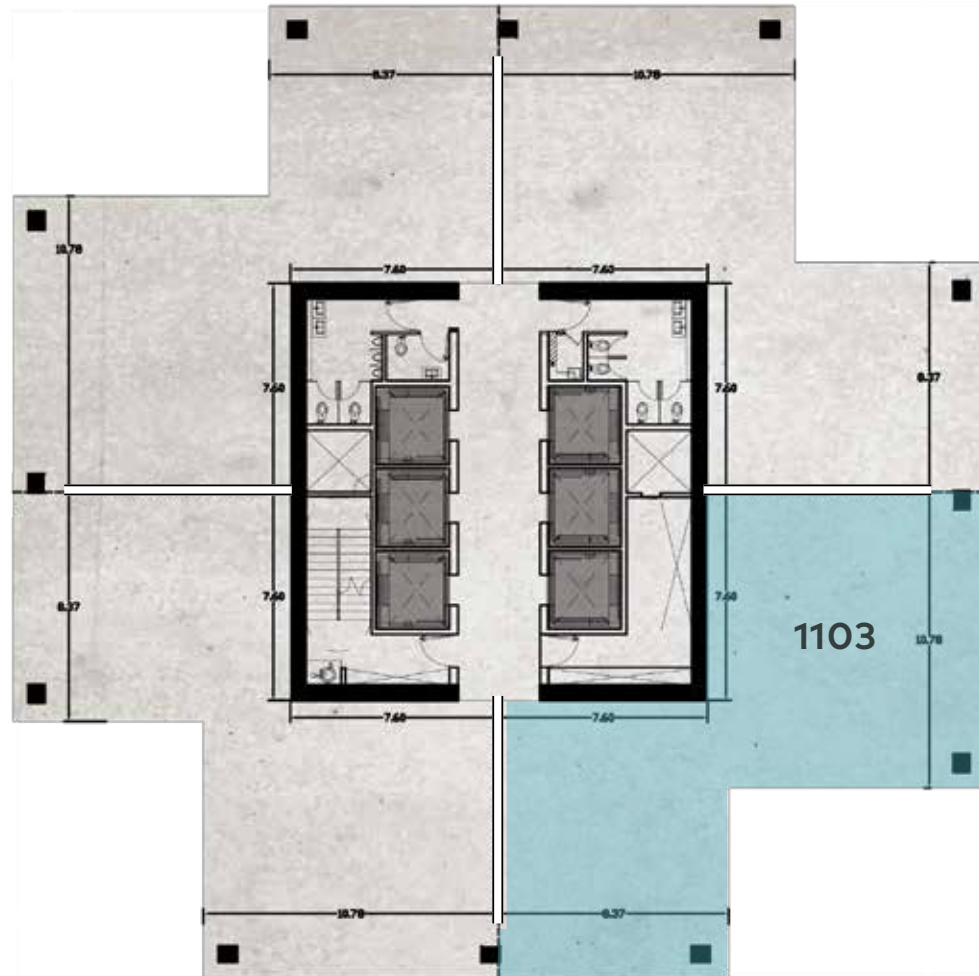

DESGLOSE DE ÁREAS

Oficina	191.15 m ²
Sanitarios	9.27 m ²
Área Común (Lobby)	12.03 m ²
Área Total	212.45 m ²



CENTRAL 200

UNIDAD

1104

NIVEL

11

ÁREA

212.5 M²

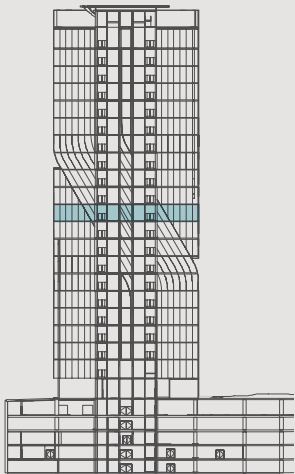

CALLE DEL COMERCIO

AVENIDA DE LA INDUSTRIA

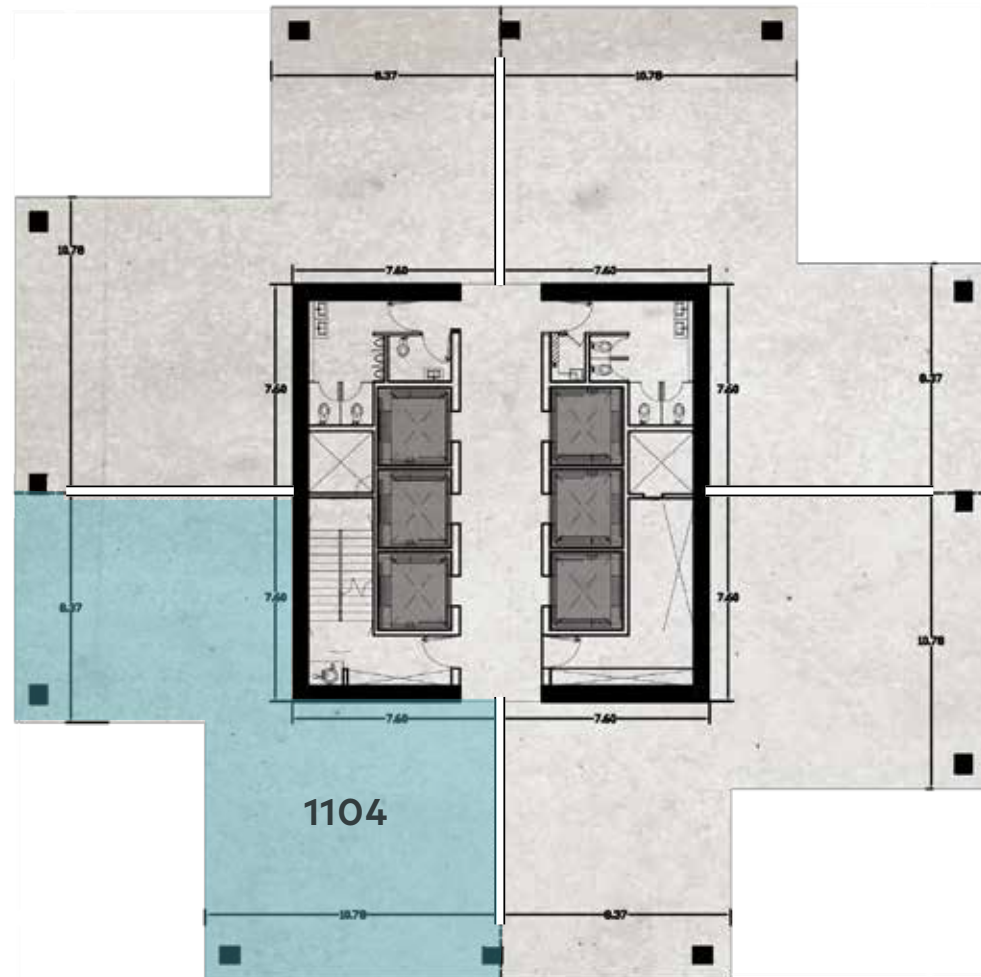

DESGLOSE DE ÁREAS

Oficina	191.15 m ²
Sanitarios	9.27 m ²
Área Común (Lobby)	12.03 m ²
Área Total	212.45 m ²



CENTRAL 200

UNIDAD

1201

NIVEL

12

ÁREA

425 M²

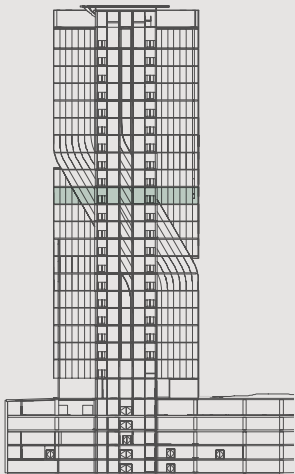

CALLE DEL COMERCIO

AVENIDA DE LA INDUSTRIA

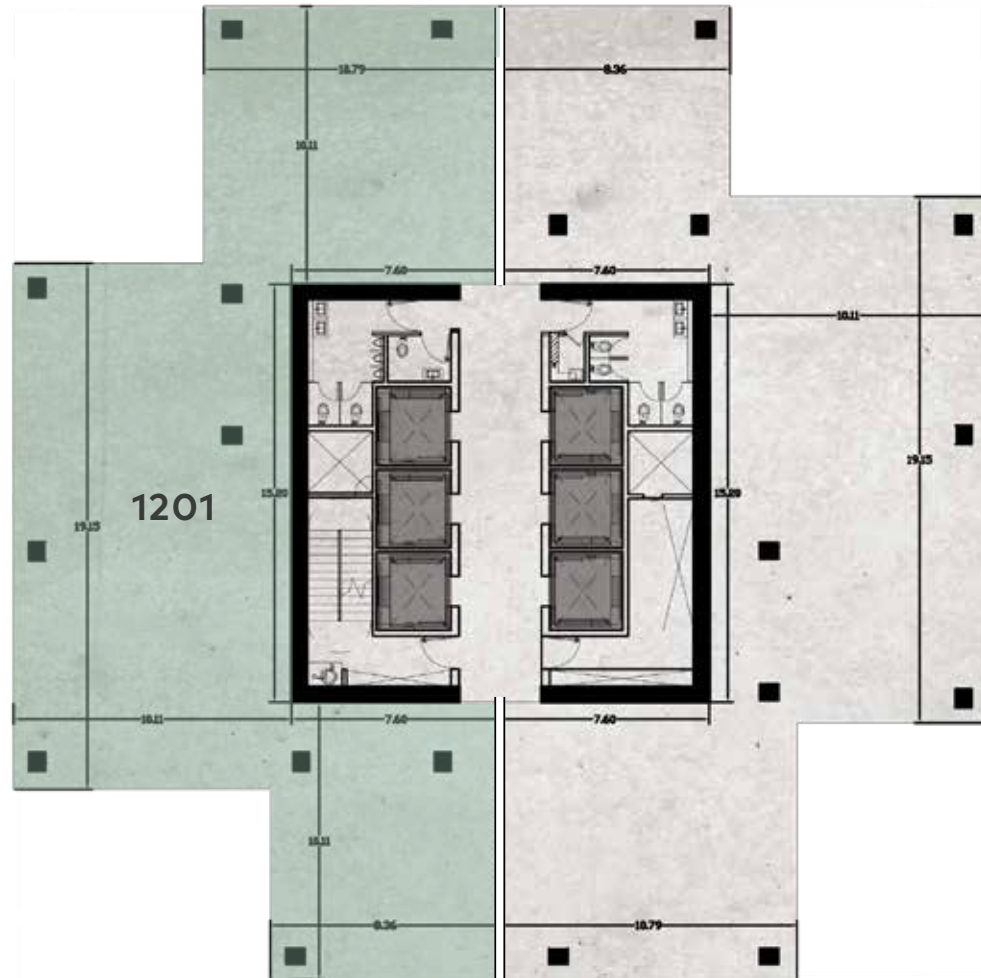

DESGLOSE DE ÁREAS

Oficina	382.34 m ²
Sanitarios	18.53 m ²
Área Común (Lobby)	24.06 m ²
Área Total	424.93 m ²



CENTRAL 200

UNIDAD

1202

NIVEL

12

ÁREA

425 M²

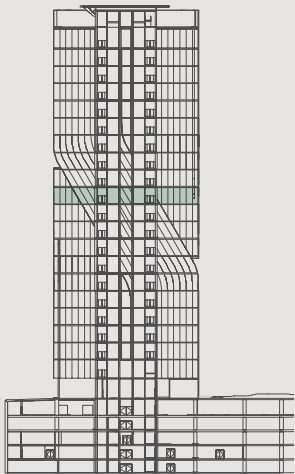

CALLE DEL COMERCIO

AVENIDA DE LA INDUSTRIA

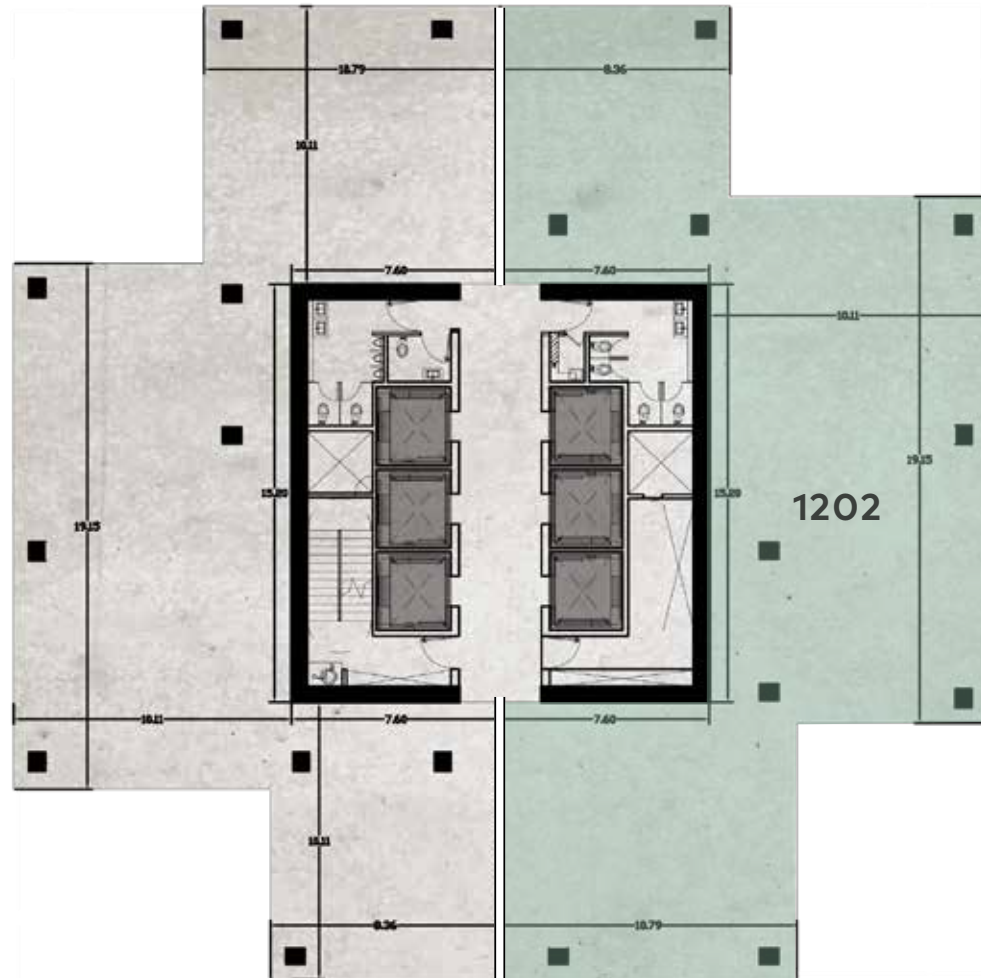

DESGLOSE DE ÁREAS

Oficina	382.34 m ²
Sanitarios	18.53 m ²
Área Común (Lobby)	24.06 m ²
Área Total	424.93 m ²



CENTRAL 200

UNIDAD

1401

NIVEL

14

ÁREA

448.4 M²

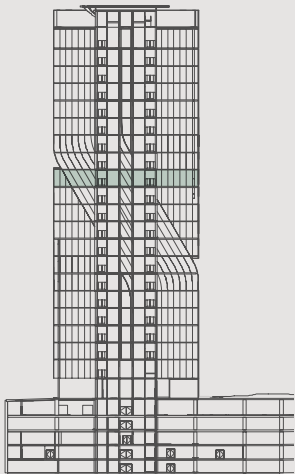

CALLE DEL COMERCIO

AVENIDA DE LA INDUSTRIA

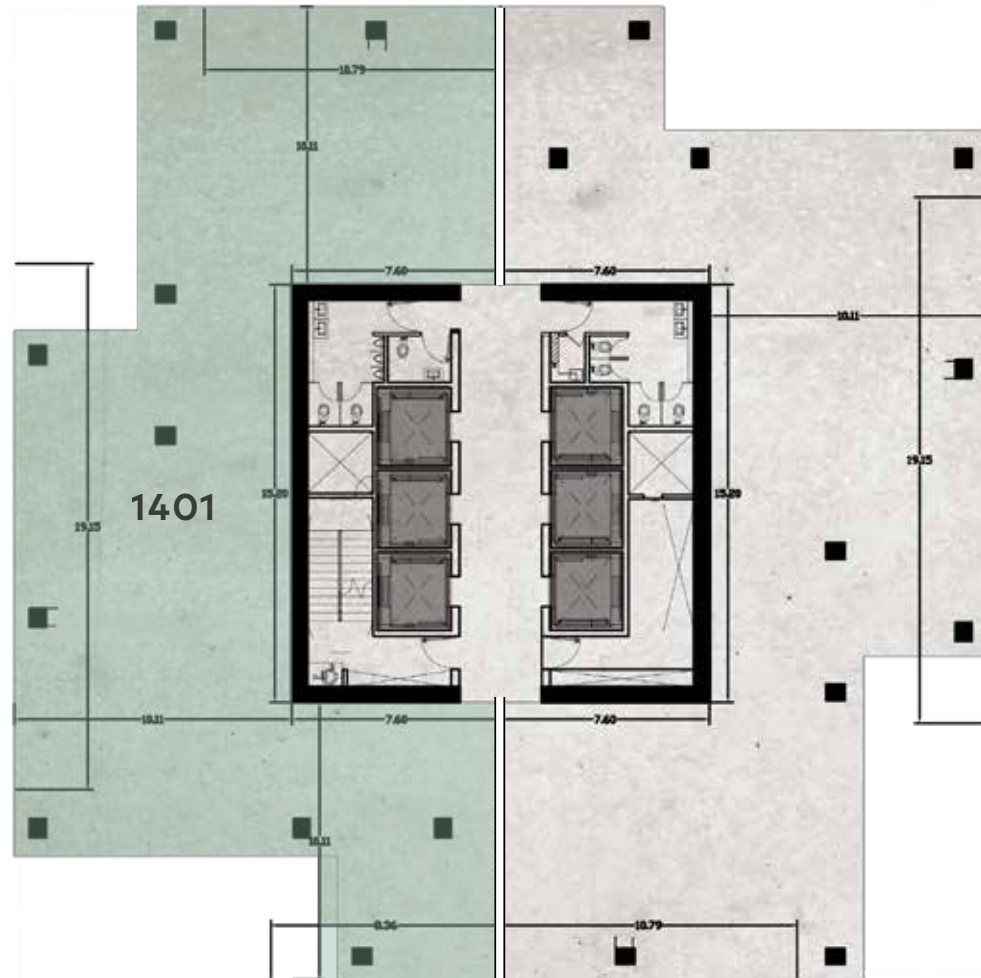

DESGLOSE DE ÁREAS

Oficina	405.81 m ²
Sanitarios	18.53 m ²
Área Común (Lobby)	24.06 m ²
Área Total	448.40 m ²



CENTRAL 200

UNIDAD

1402

NIVEL

14

ÁREA

448.4 M²

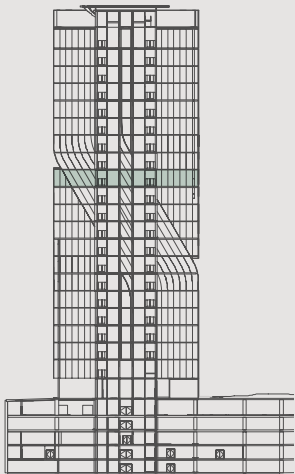

CALLE DEL COMERCIO

AVENIDA DE LA INDUSTRIA

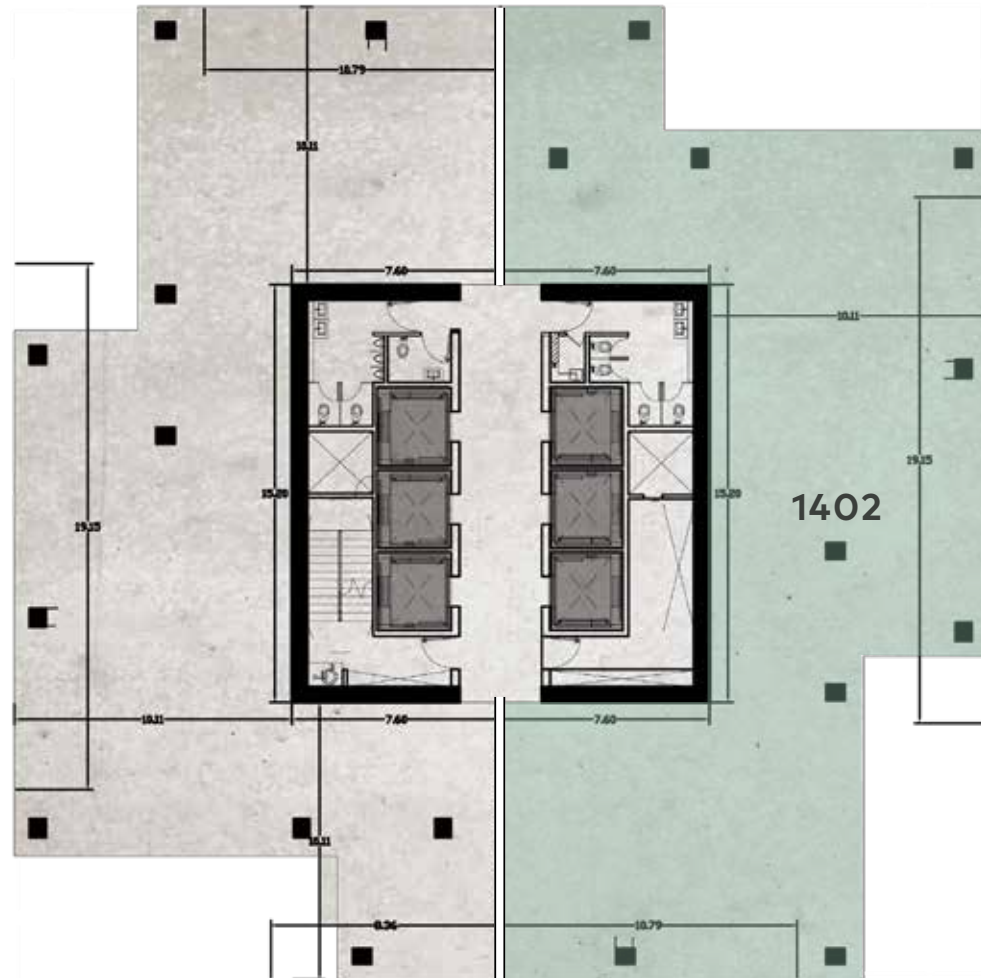

DESGLOSE DE ÁREAS

Oficina	405.81 m ²
Sanitarios	18.53 m ²
Área Común (Lobby)	24.06 m ²
Área Total	448.40 m ²



CENTRAL 200

UNIDAD

1501

NIVEL

15

ÁREA

500 M²

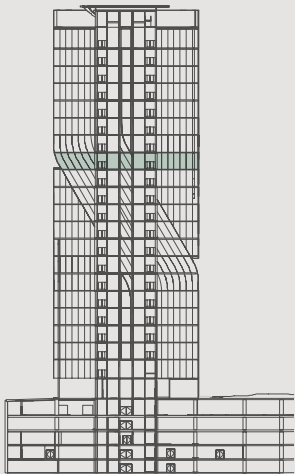

CALLE DEL COMERCIO

AVENIDA DE LA INDUSTRIA

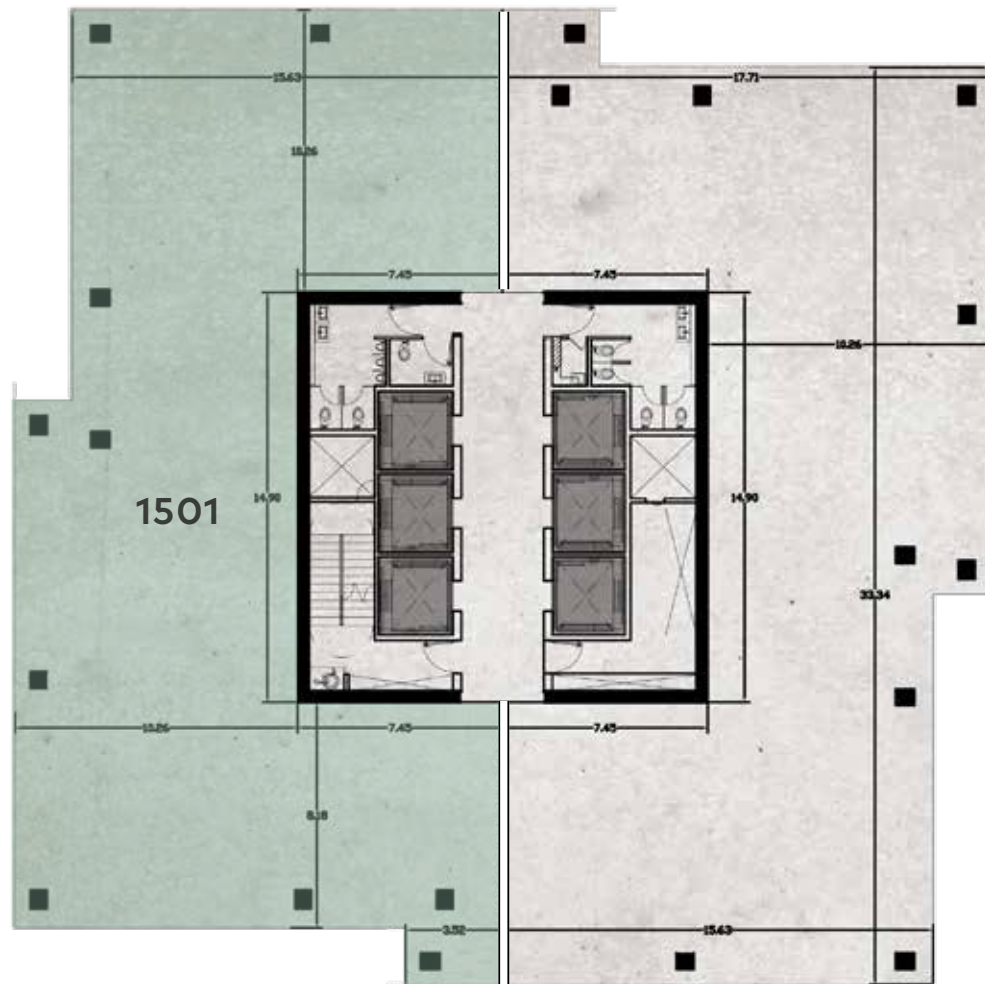

DESGLOSE DE ÁREAS

Oficina	457.23 m ²
Sanitarios	18.53 m ²
Área Común (Lobby)	24.06 m ²
Área Total	499.82 m ²



CENTRAL 200

UNIDAD

1502

NIVEL

15

ÁREA

500 M²

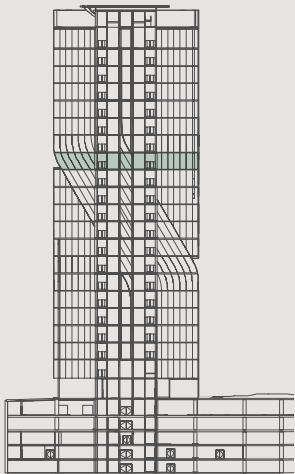

CALLE DEL COMERCIO

AVENIDA DE LA INDUSTRIA

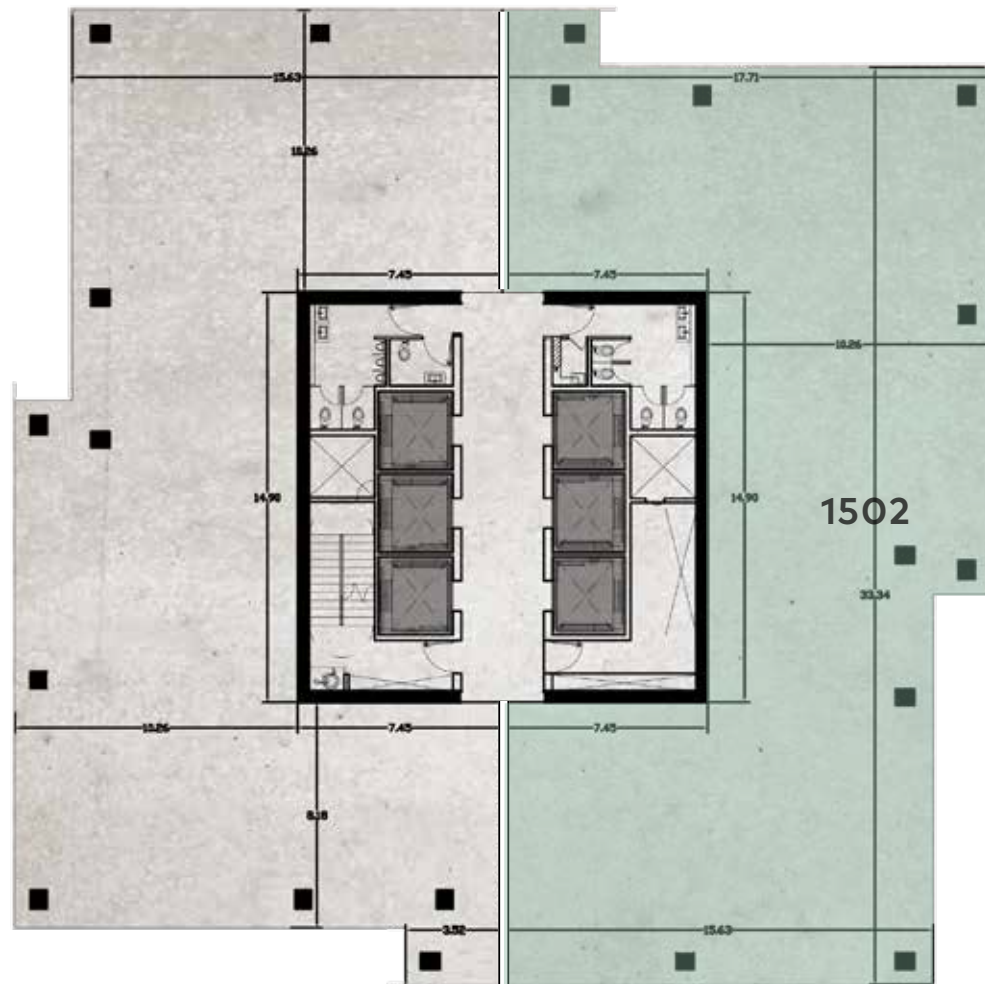

DESGLOSE DE ÁREAS

Oficina	457.23 m ²
Sanitarios	18.53 m ²
Área Común (Lobby)	24.06 m ²
Área Total	499.82 m ²



CENTRAL 200

UNIDAD

1601

NIVEL

16

ÁREA

550 M²

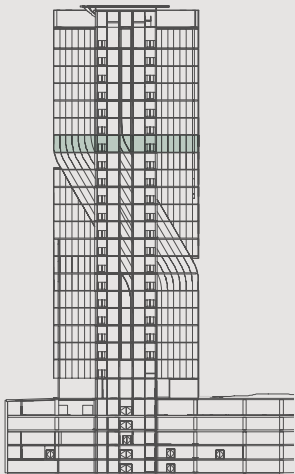

CALLE DEL COMERCIO

AVENIDA DE LA INDUSTRIA

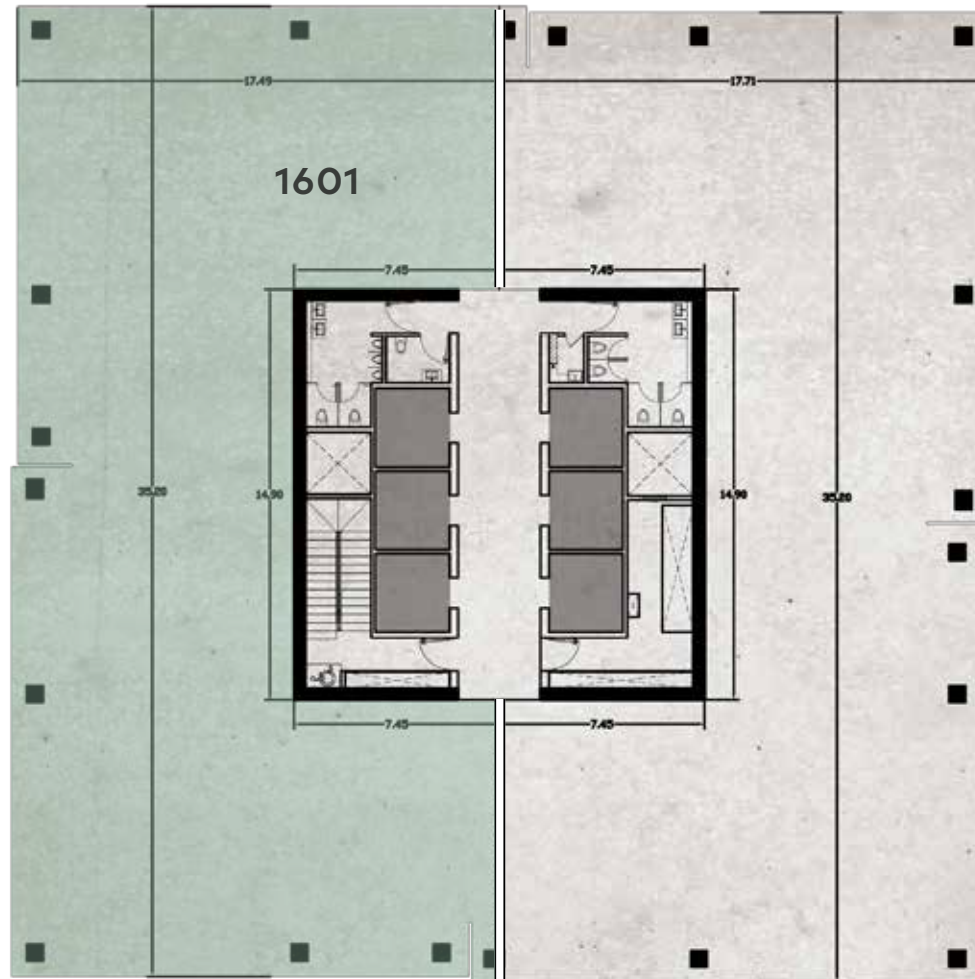

DESGLOSE DE ÁREAS

Oficina	508.47 m ²
Sanitarios	18.53 m ²
Área Común (Lobby)	23.61 m ²
Área Total	550.61 m ²



CENTRAL 200

UNIDAD

1602

NIVEL

16

ÁREA

550 M²

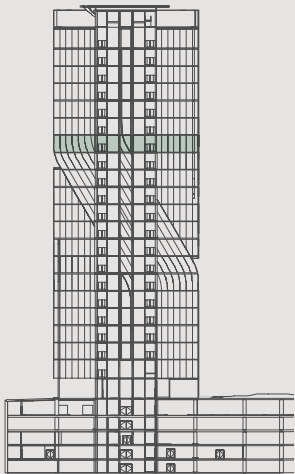

CALLE DEL COMERCIO

AVENIDA DE LA INDUSTRIA

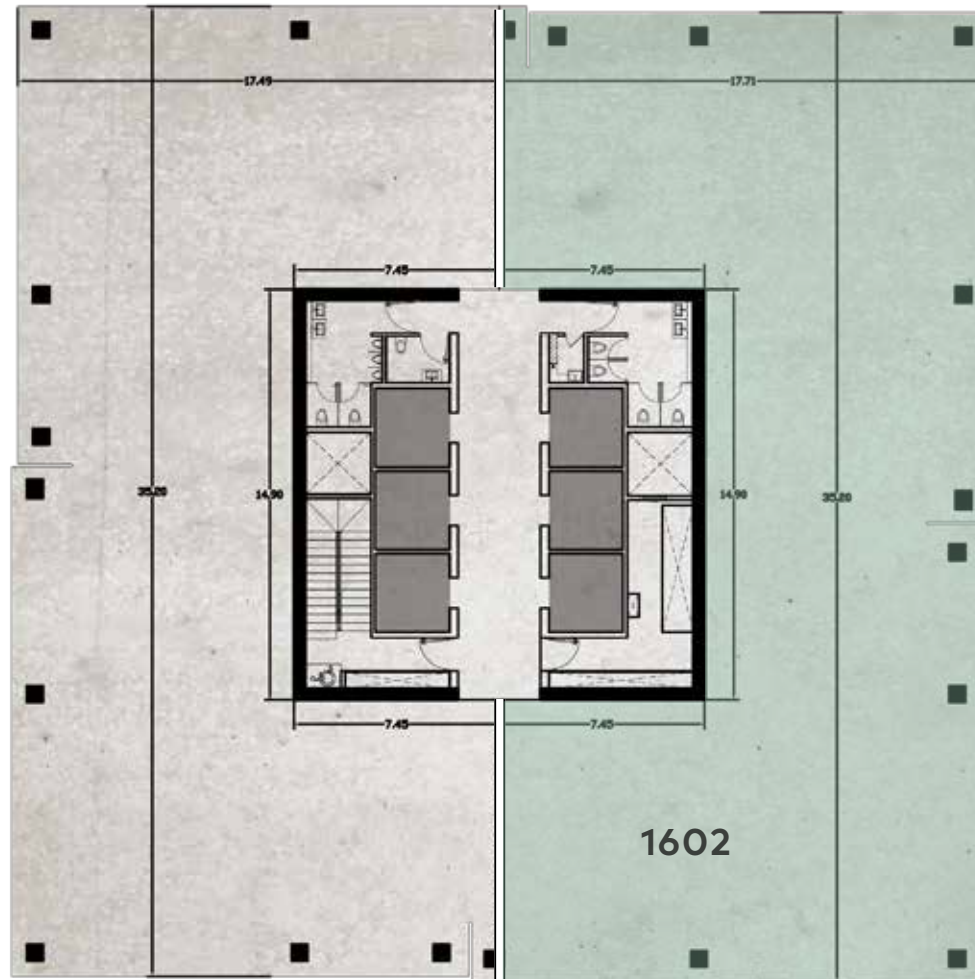

DESGLOSE DE ÁREAS

Oficina	508.47 m ²
Sanitarios	18.53 m ²
Área Común (Lobby)	23.61 m ²
Área Total	550.61 m ²



CENTRAL 200

UNIDAD

1701

NIVEL

17

ÁREA

551 M²

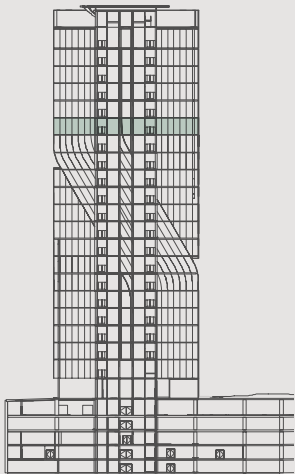

CALLE DEL COMERCIO

AVENIDA DE LA INDUSTRIA

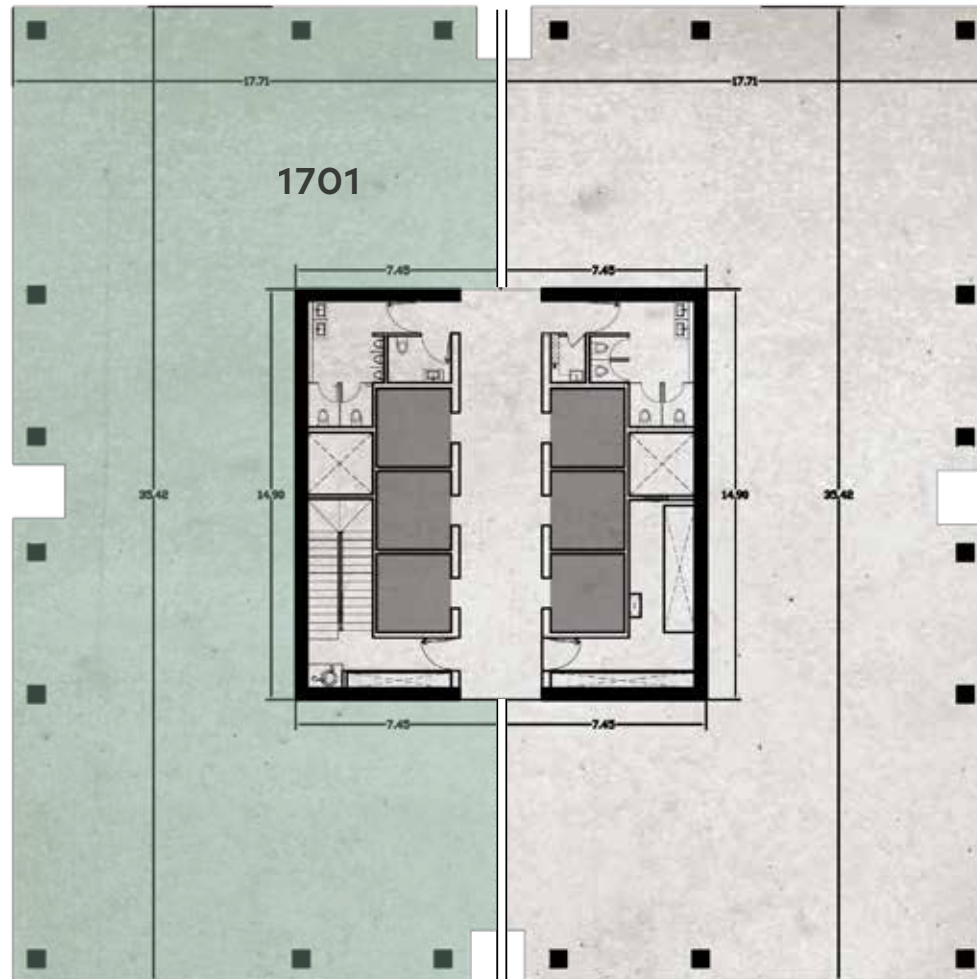

DESGLOSE DE ÁREAS

Oficina	508.73 m ²
Sanitarios	18.53 m ²
Área Común (Lobby)	23.61 m ²
Área Total	550.87 m ²



CENTRAL 200

UNIDAD

1702

NIVEL

17

ÁREA

551 M²

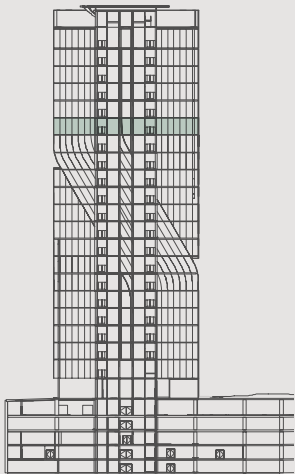

CALLE DEL COMERCIO

AVENIDA DE LA INDUSTRIA

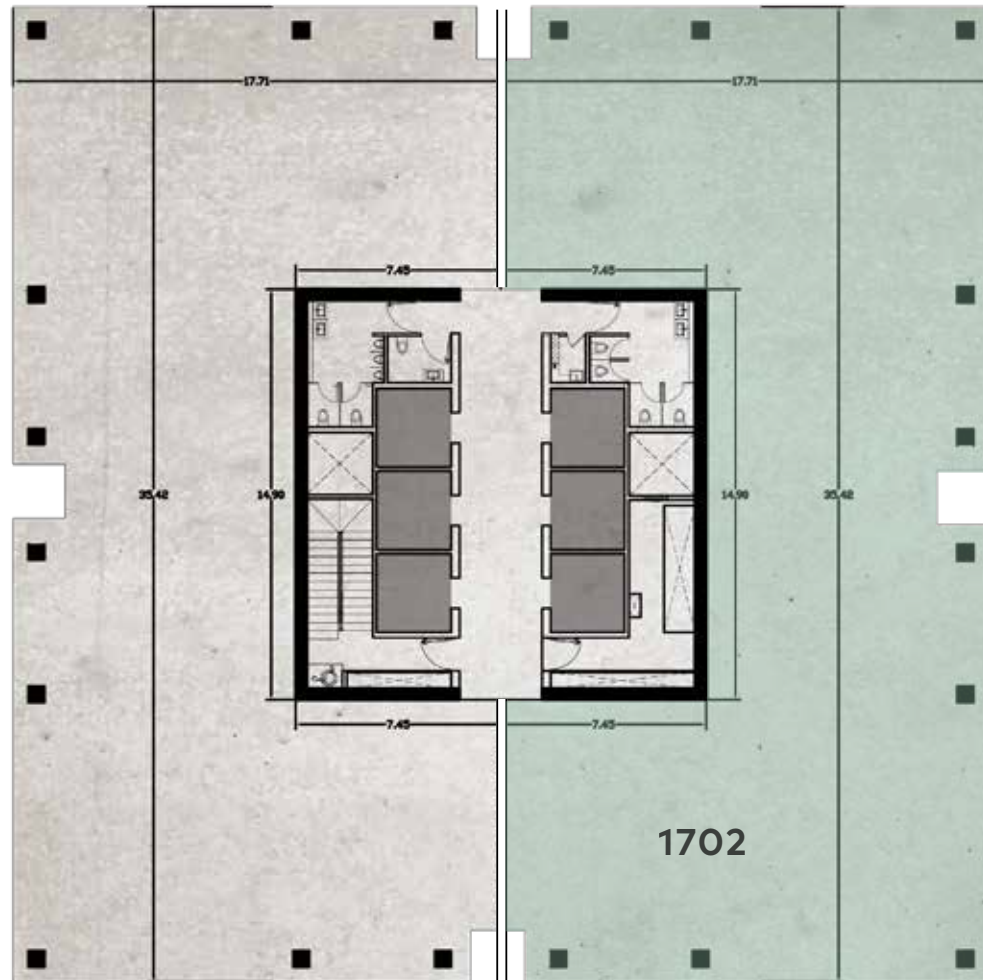

DESGLOSE DE ÁREAS

Oficina	508.73 m ²
Sanitarios	18.53 m ²
Área Común (Lobby)	23.61 m ²
Área Total	550.87 m ²



CENTRAL 200

UNIDAD

1801

NIVEL

18

ÁREA

1,100 M²

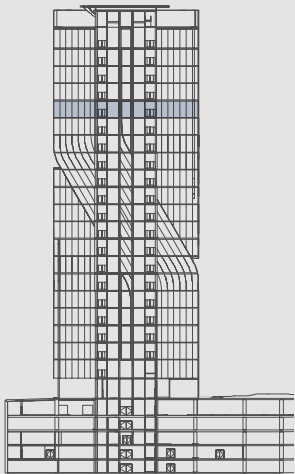

CALLE DEL COMERCIO

AVENIDA DE LA INDUSTRIA

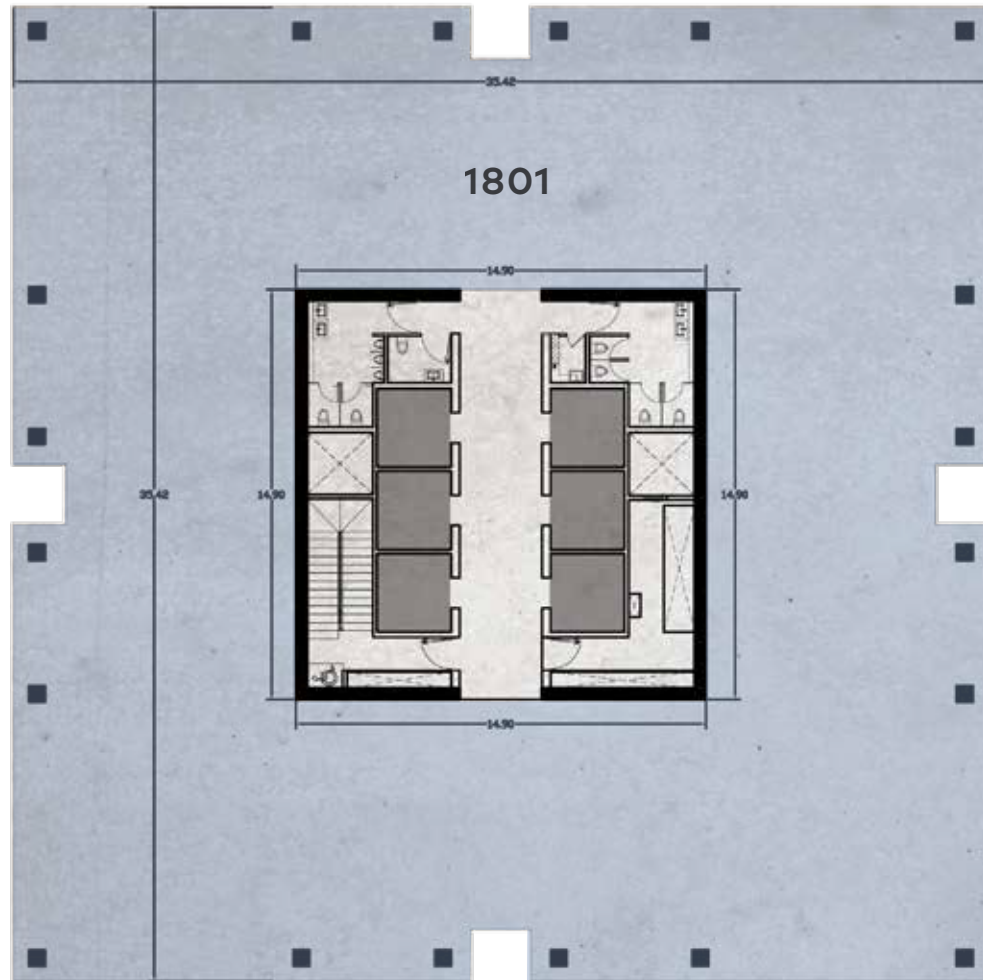

DESGLOSE DE ÁREAS

Oficina	1,015.76 m ²
Sanitarios	37.06 m ²
Área Común (Lobby)	47.55 m ²
Área Total	1,100.37 m ²



CENTRAL 200

UNIDAD

1901

NIVEL

19

ÁREA

1,100 M²

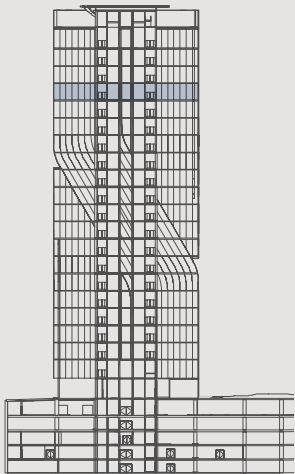

CALLE DEL COMERCIO

AVENIDA DE LA INDUSTRIA

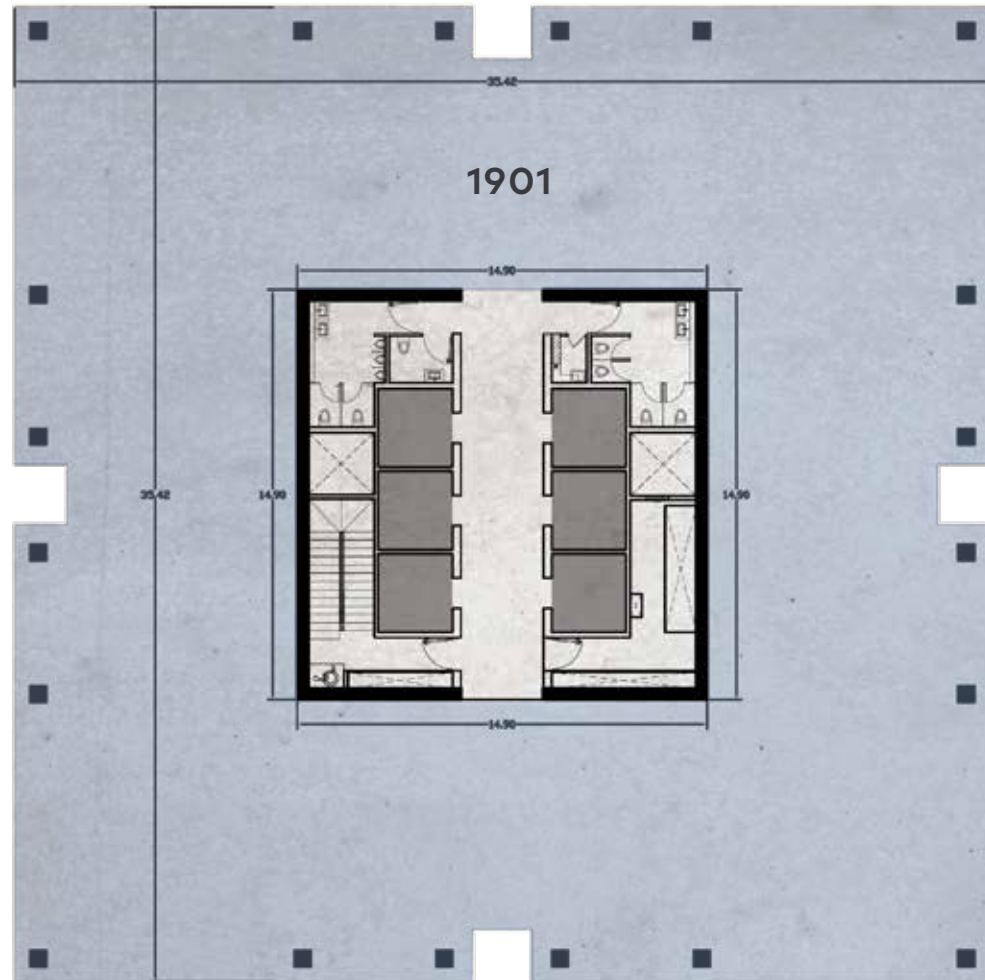

DESGLOSE DE ÁREAS

Oficina	1,015.76 m ²
Sanitarios	37.06 m ²
Área Común (Lobby)	47.22 m ²
Área Total	1,100.04 m ²



CENTRAL 200

UNIDAD

2001

NIVEL

20

ÁREA

1,094 M²

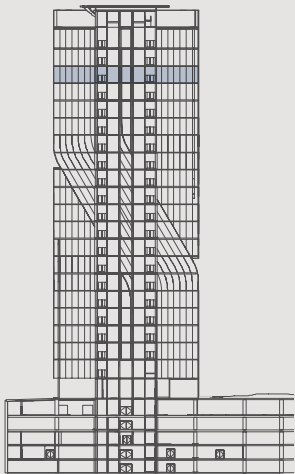

CALLE DEL COMERCIO

AVENIDA DE LA INDUSTRIA

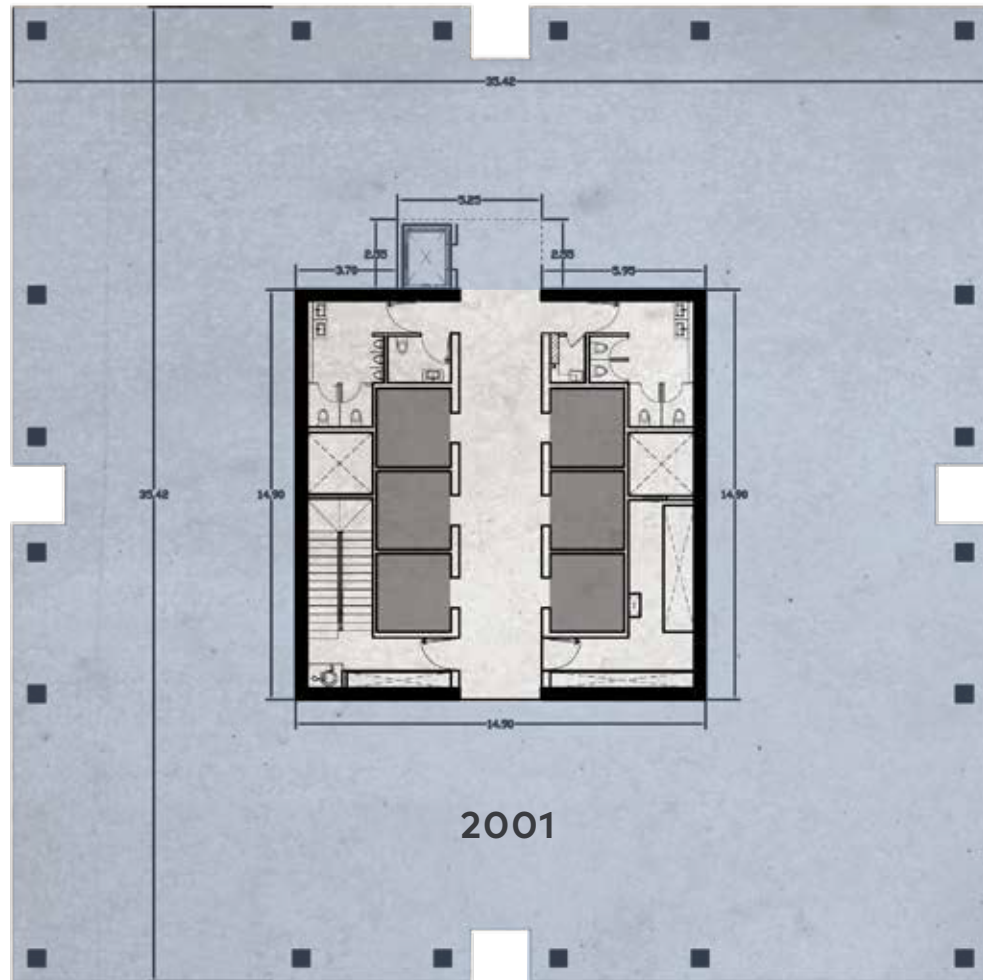

DESGLOSE DE ÁREAS

Oficina	1,002.37 m ²
Sanitarios	37.06 m ²
Área Común (Lobby)	54.87 m ²
Área Total	1,094.30 m ²



CENTRAL 200

UNIDAD

2101

NIVEL

21

ÁREA

1,094 M²

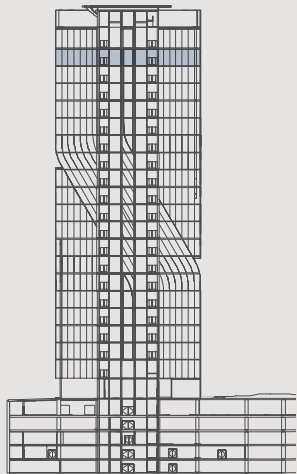

CALLE DEL COMERCIO

AVENIDA DE LA INDUSTRIA

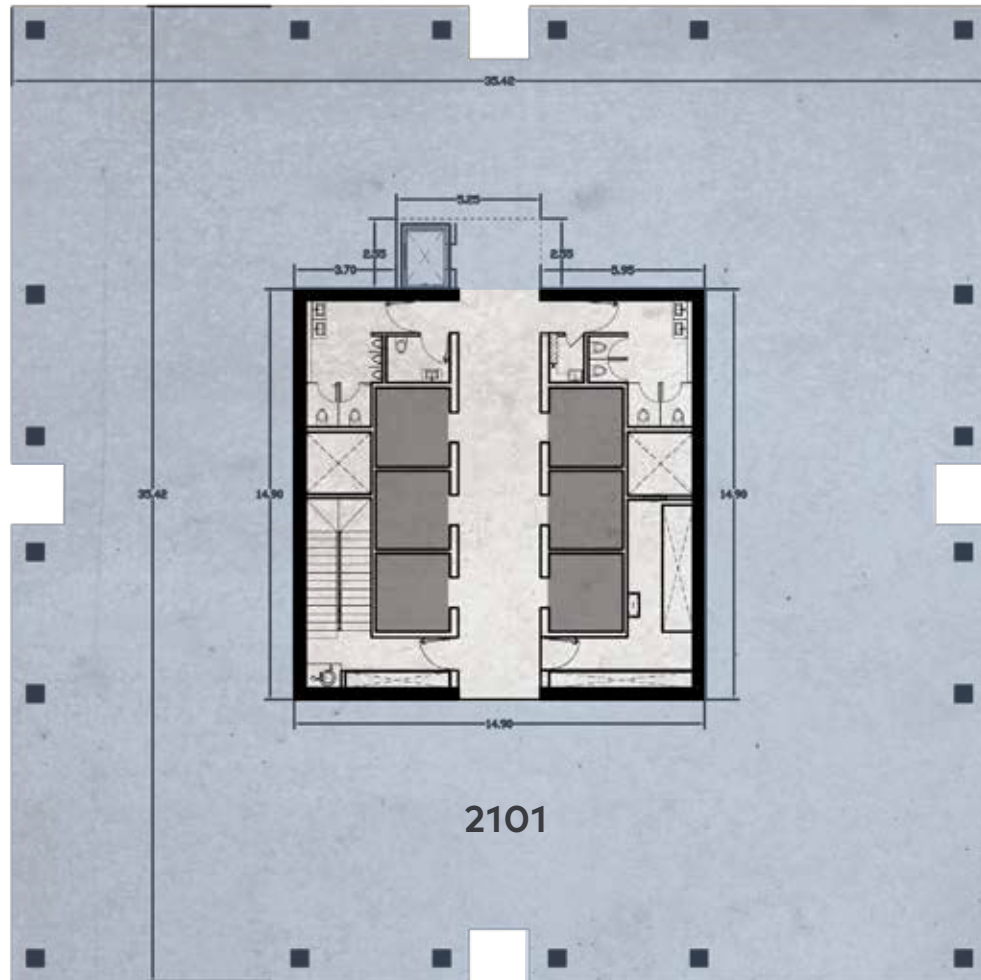

DESGLOSE DE ÁREAS

Oficina	1,002.37 m ²
Sanitarios	37.06 m ²
Área Común (Lobby)	54.87 m ²
Área Total	1,094.30 m ²



CENTRAL 200

UNIDAD

2201

NIVEL

PH

ÁREA

1,095 M²

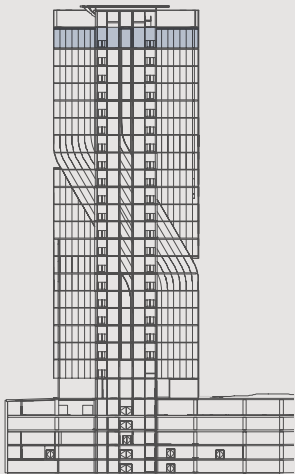

CALLE DEL COMERCIO

AVENIDA DE LA INDUSTRIA

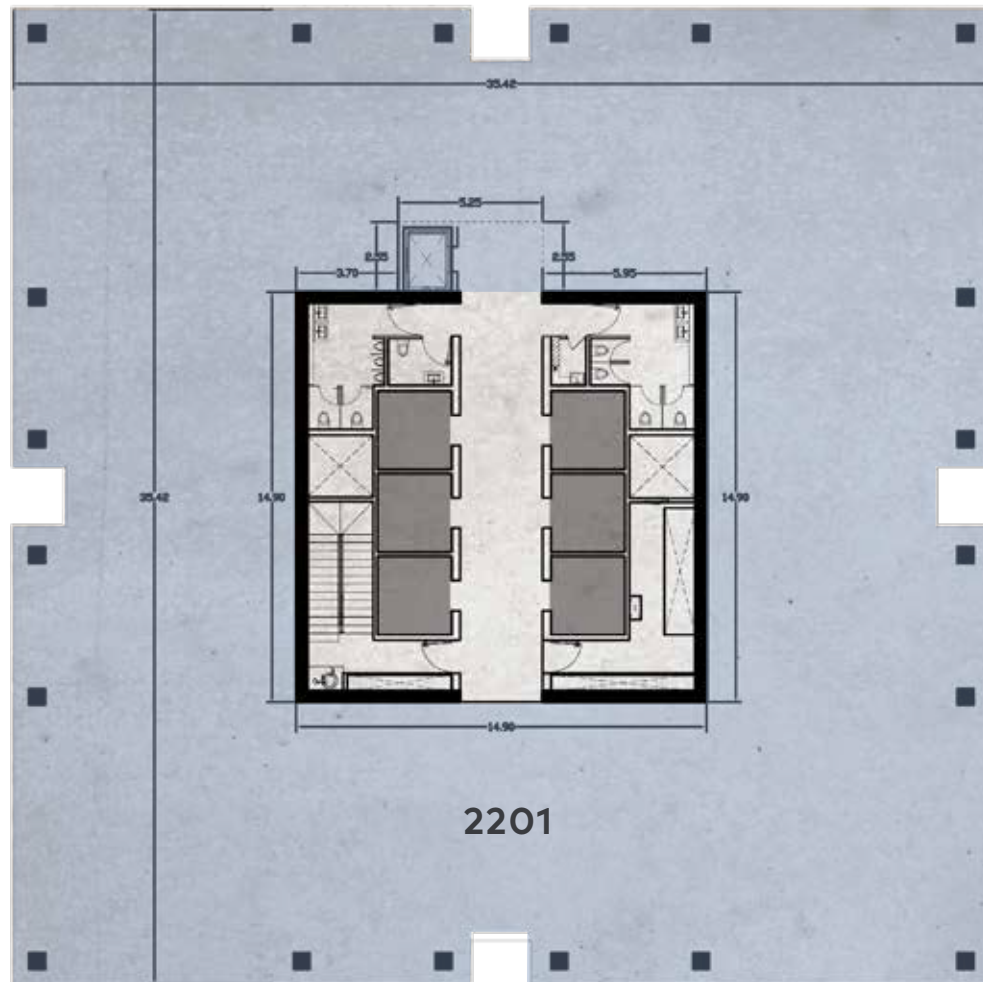

DESGLOSE DE ÁREAS

Oficina	1,003.03 m ²
Sanitarios	37.06 m ²
Área Común (Lobby)	54.87 m ²
Área Total	1,094.96 m ²