

SHAKESPEARE 83
Anzures, CDMX



*LOS PROYECTOS PUEDEN SUFRIR MODIFICACIONES SIEMPRE BUSCANDO LA MEJORA DEL MISMO





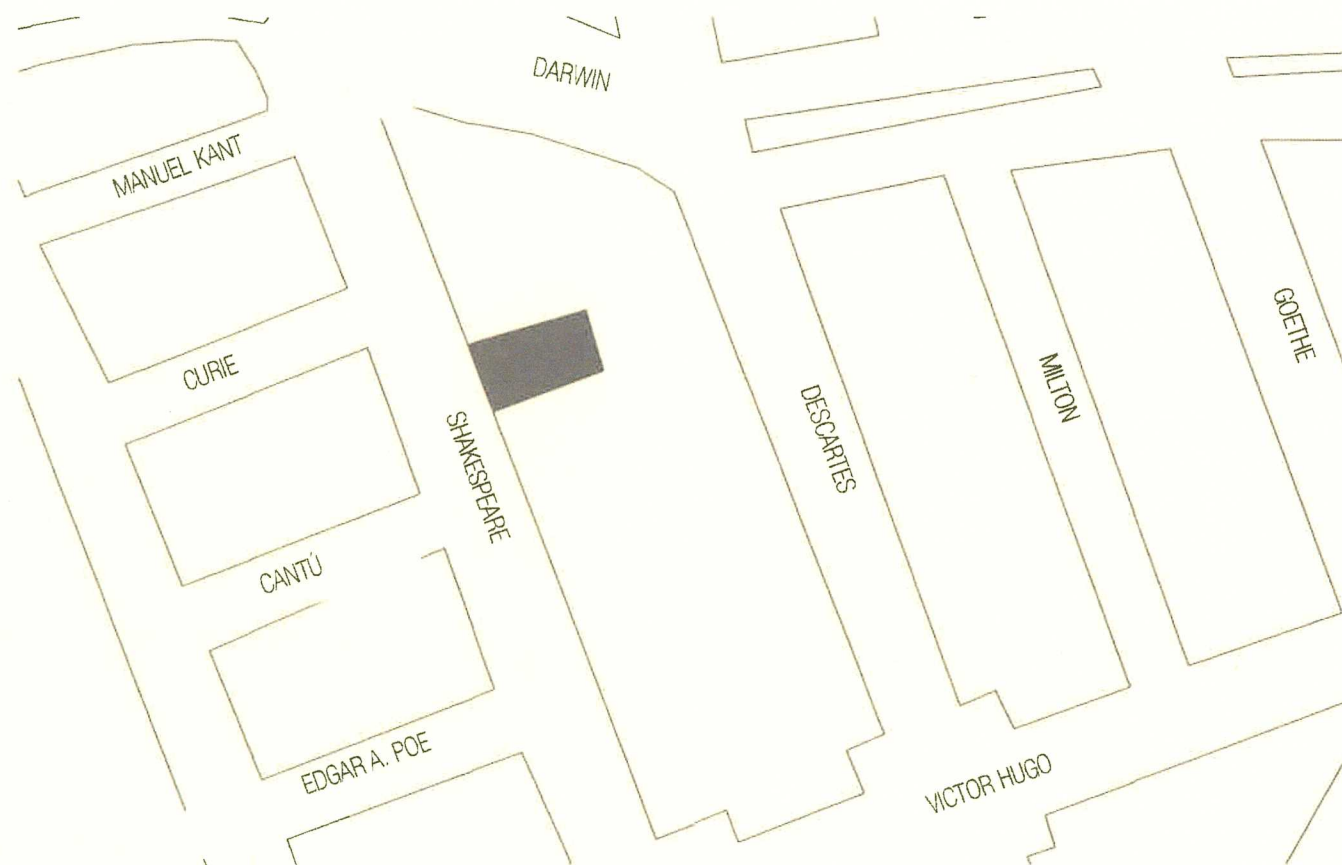



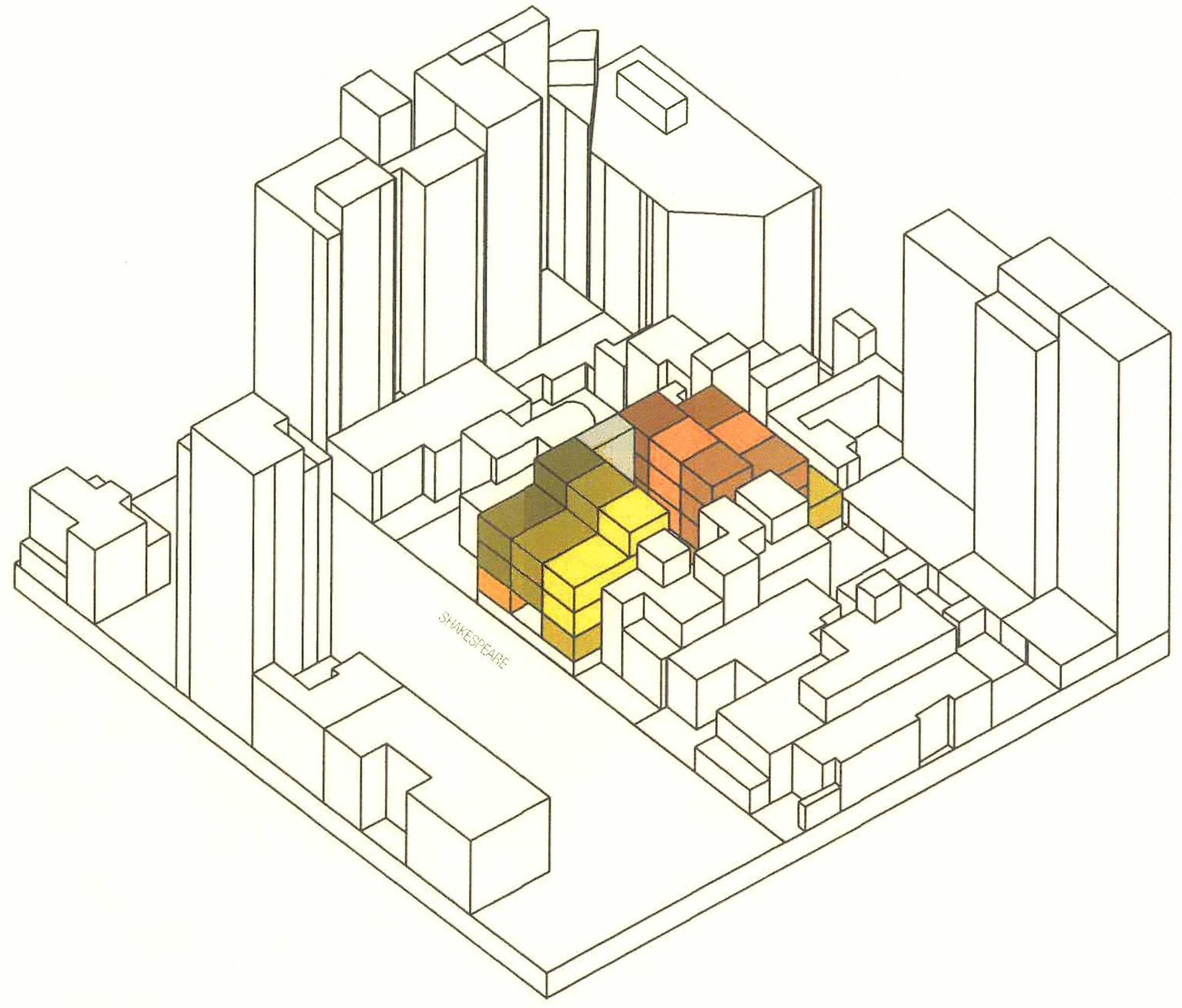





UBICACIÓN



-  Garden House 101
-  Garden House 102
-  Garden House 103
-  PH 201
-  PH 202
-  PH 203
-  PH 204
-  PH 205
-  PH 206

ESQUEMA DISTRIBUCIÓN

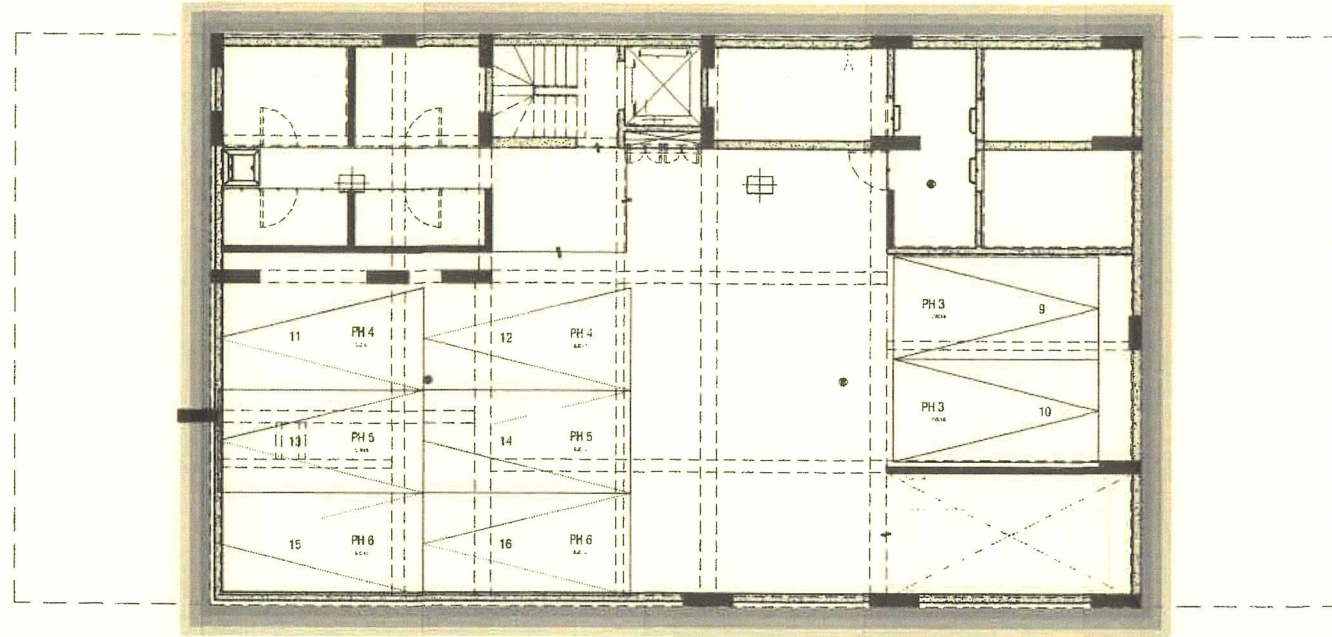

Planta Sótano

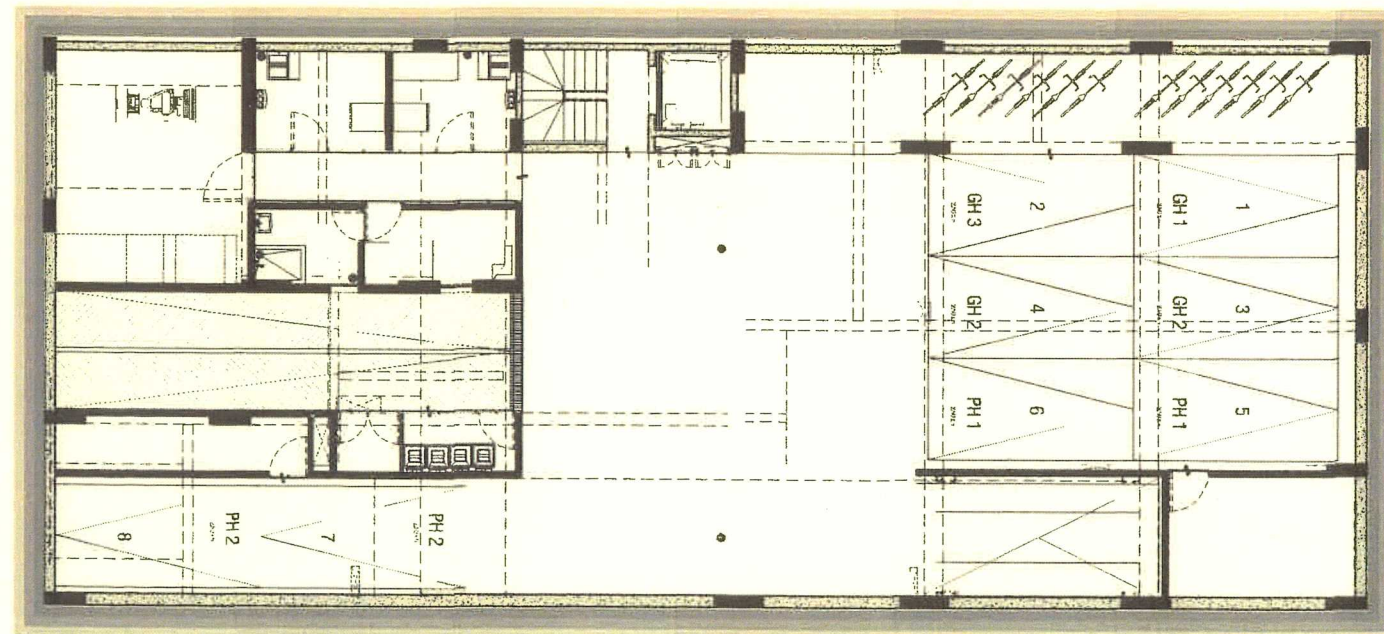

Planta Semisótano

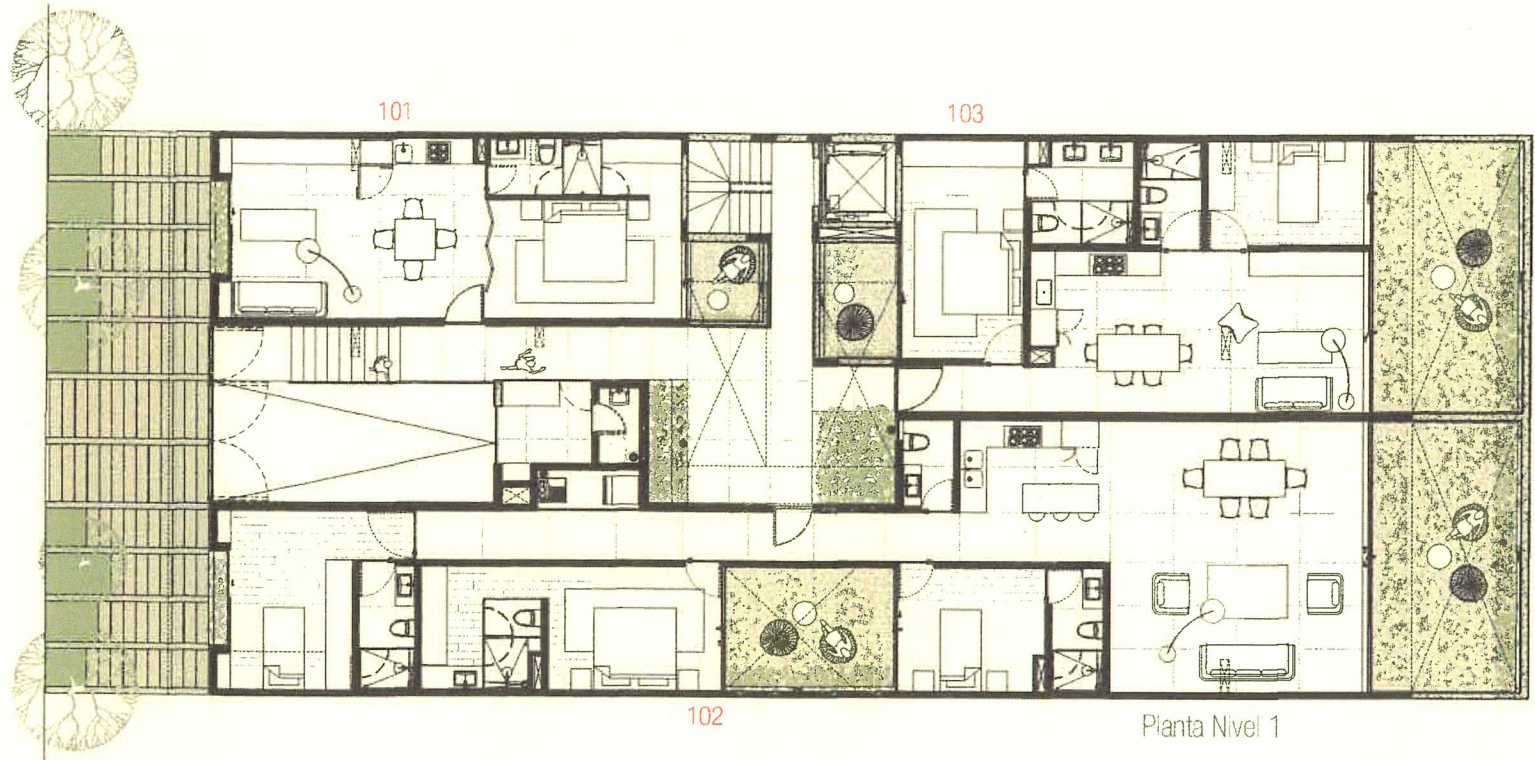

Planta Nivel 1

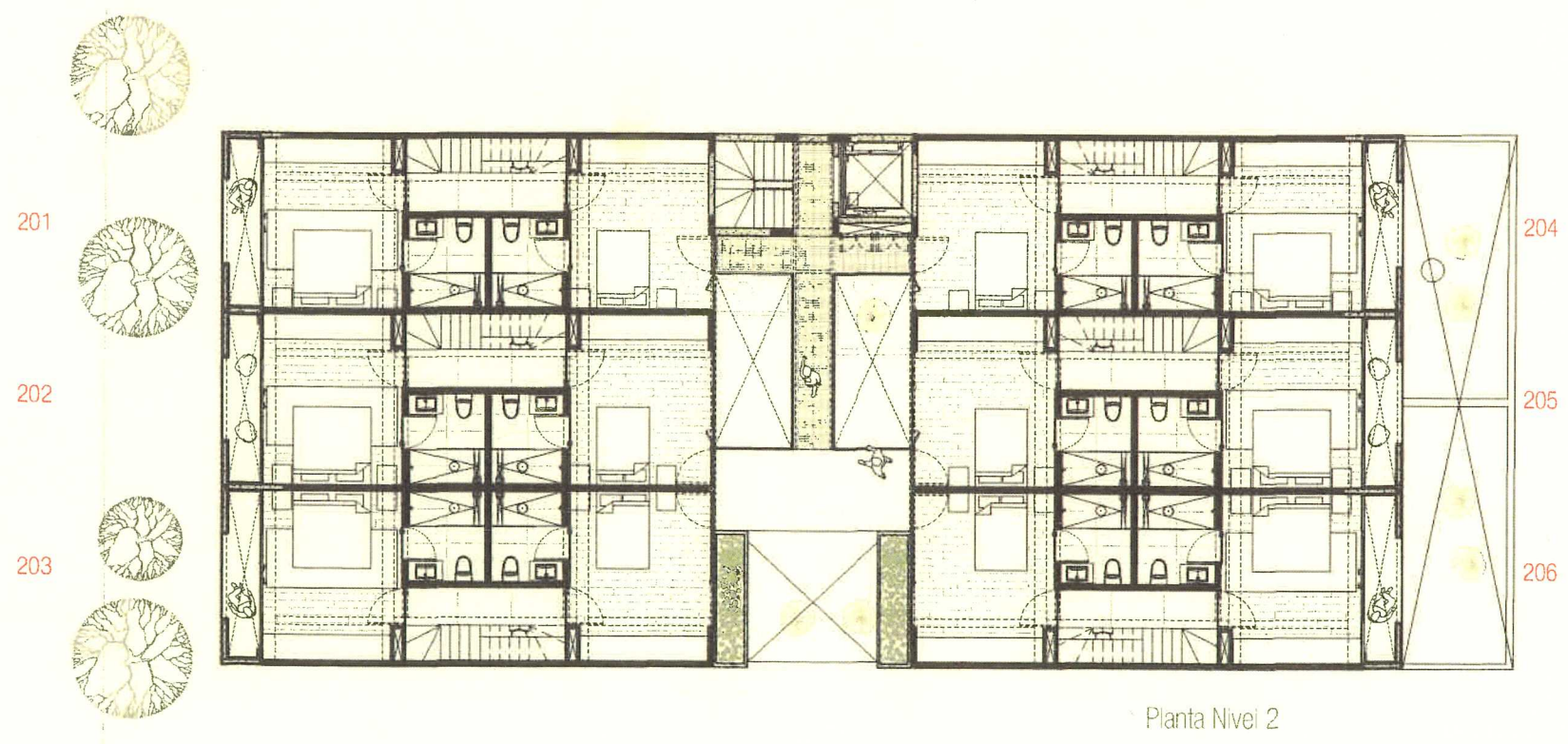

Planta Nivel 2

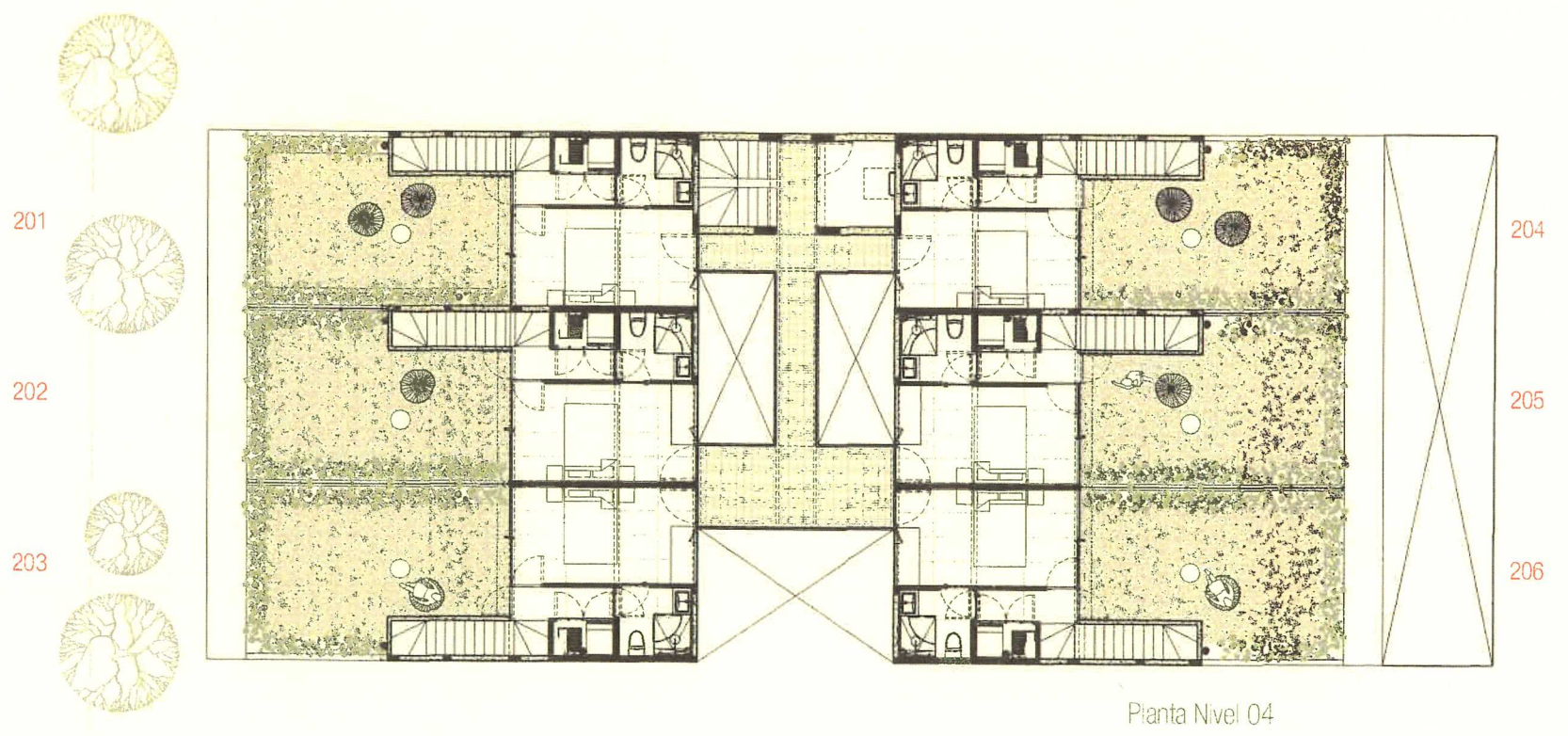
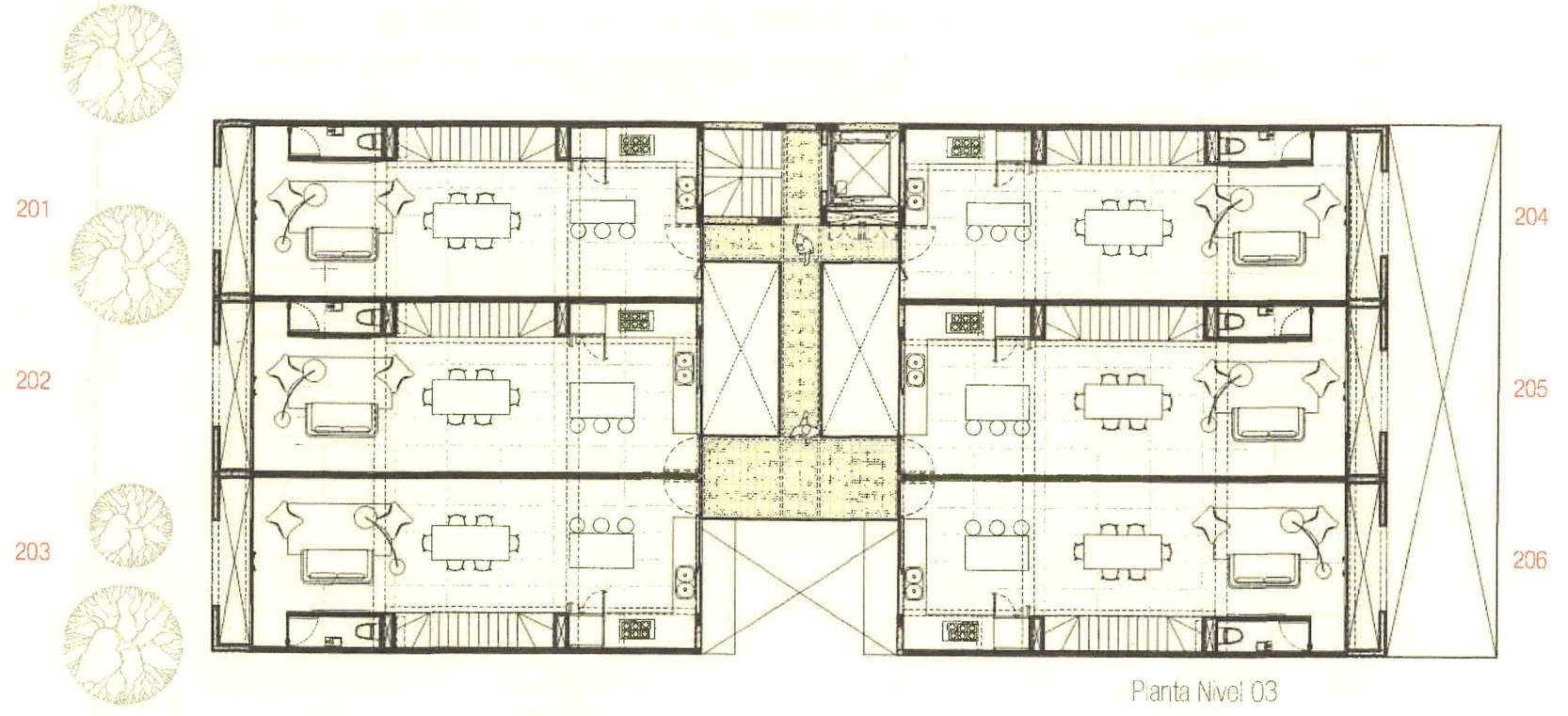

Garden Houses
101 . 102 . 103

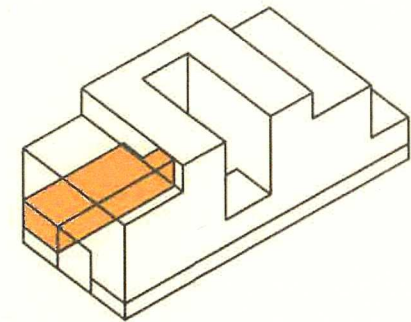

Garden House 101

54.10 m² privados
 3.58 m² terraza
 8.54 m² cuarto de lavado
 66.07 m² totales
 1 cajón estacionamiento

- 1 Estancia
- 2 Comedor
- 3 Cocina
- 4 Cto. Lavado
- 5 Recamara Principal
- 6 Baño / Vestidor
- 7 Terraza

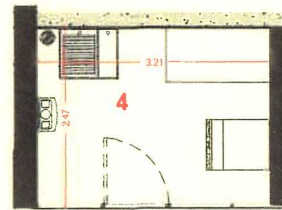

Cuarto de Lavado
 Nivel Semisótano

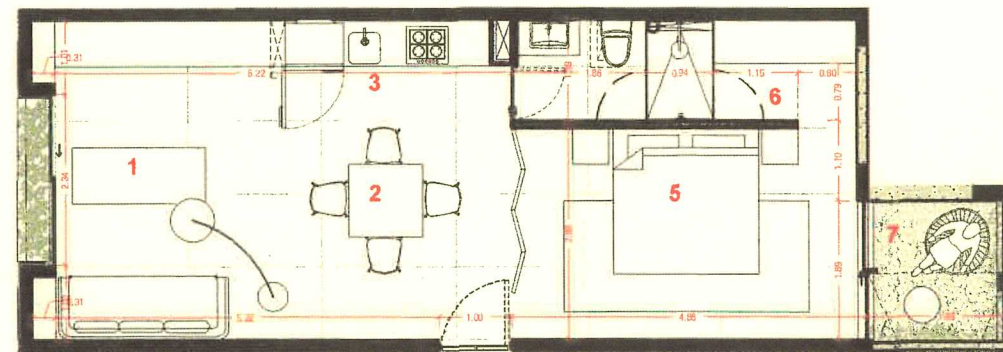

Planta GH

0 1 2.5 5 7.5 10



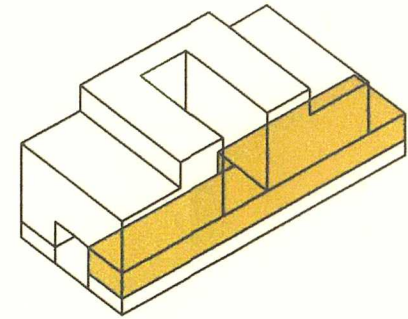

Garden House 102

146.61 m² privados
 39.31 m² terrazas
 13.16 m² cuarto de servicio
 199.08 m² totales
 2 cajones estacionamiento

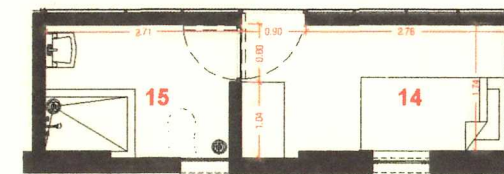

Cuarto de Servicio
 Nivel Semisótano

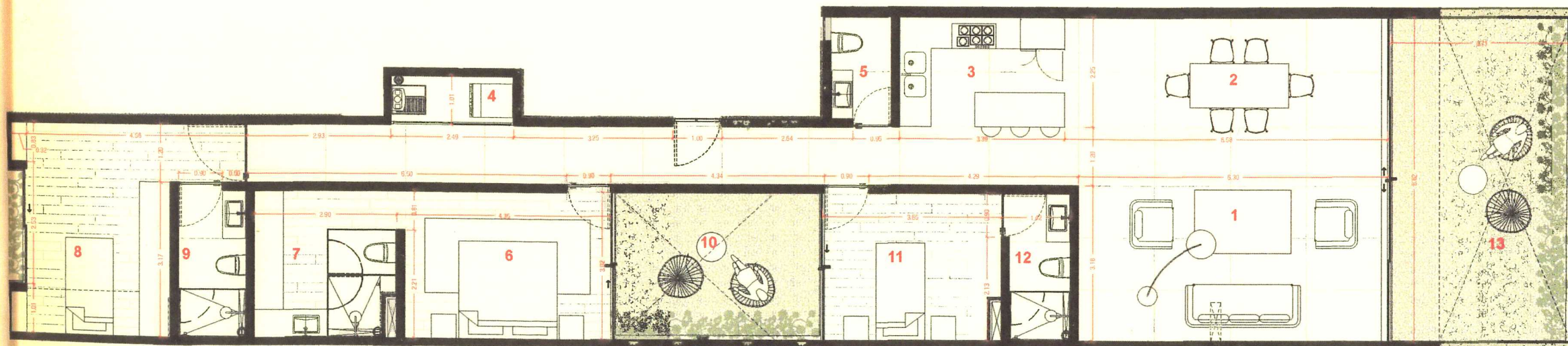

Planta GH

- 1 Estancia
- 2 Comedor
- 3 Cocina
- 4 Cto. Lavado
- 5 Baño Visitas
- 6 Recamara Principal
- 7 Baño / Vestidor principal
- 8 Recamara 2
- 9 Baño 2
- 10 Patio
- 11 Recámara 3
- 12 Baño 3
- 13 Terraza
- 14 Cuarto de servicio
- 15 Baño de servicio

0 1 2.5 5 7.5 10





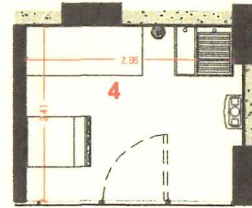

Cuarto de Lavado
Nivel Semisótano

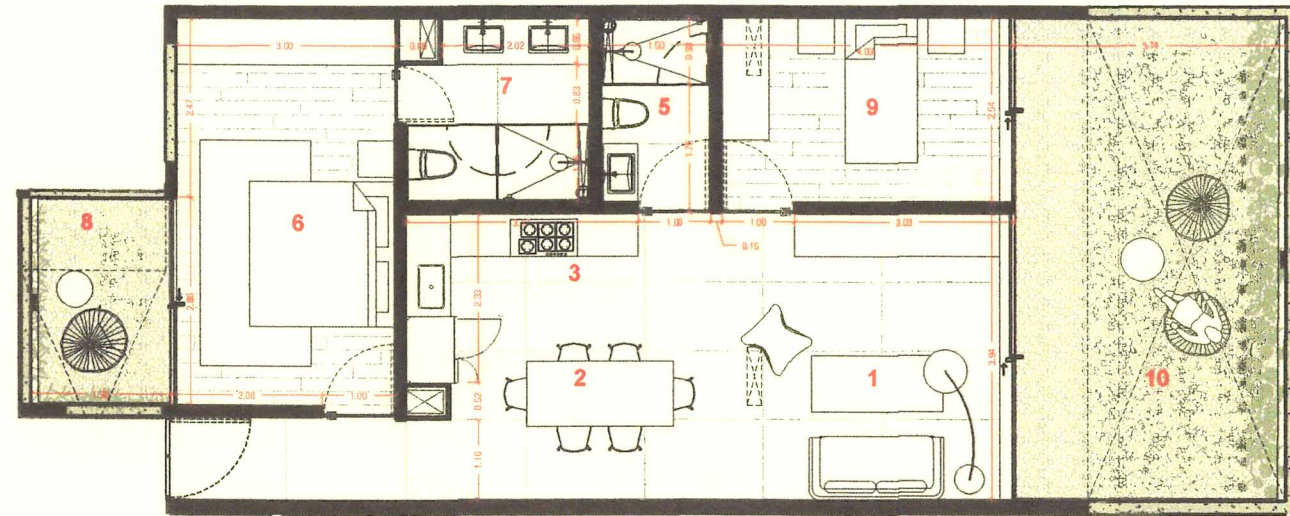

Planta G1

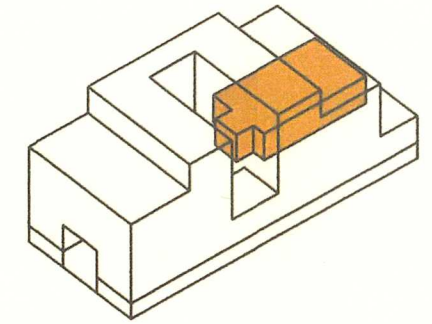

Garden House 103

76.68 m² privados
 32.97 m² terrazas
 8.39 m² cuarto de lavado
 109.65 m² totales
 1 cajón estacionamiento

- 1 Estancia
- 2 Comedor
- 3 Cocina
- 4 Cto. Lavado
- 5 Baño Visitas
- 6 Recamara Principal
- 7 Baño / Vestidor principal
- 8 Terraza Recámara Principal
- 9 Recamara 2
- 10 Terraza

0 1 2.5 5 7.5 10



Pent House
201 . 202 . 203
204 . 205 . 206

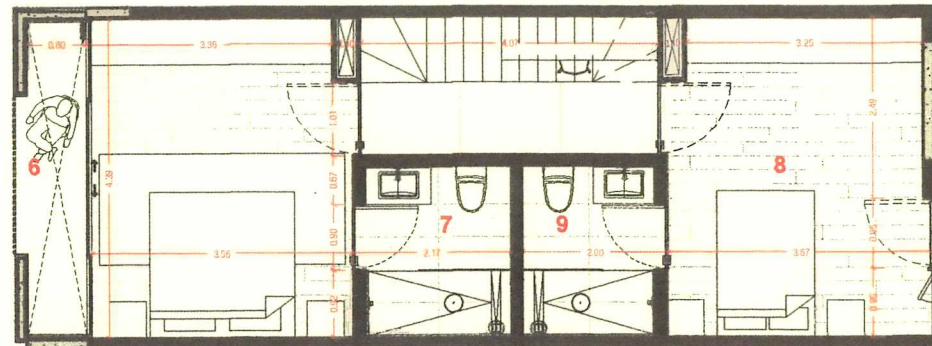

Pent House Nivel 1

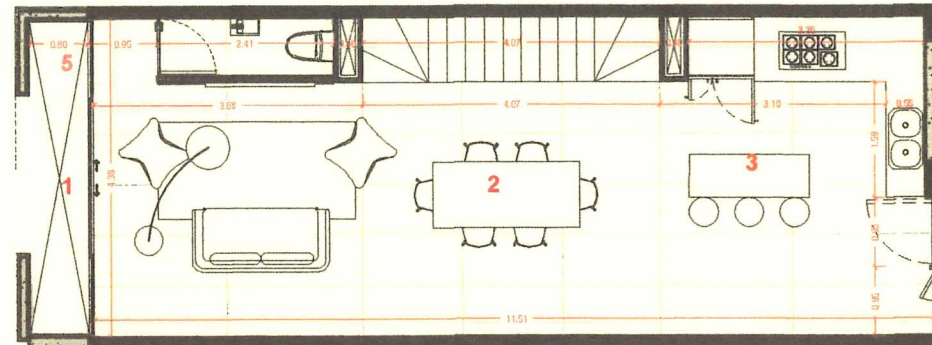

Pent House Nivel 2

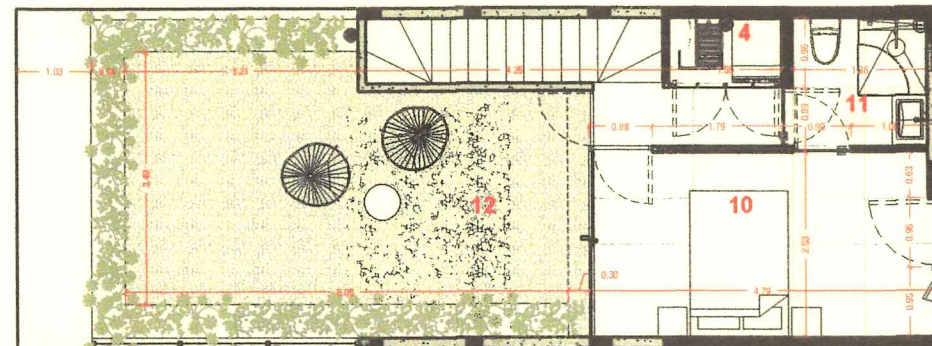

Pent House Nivel 3

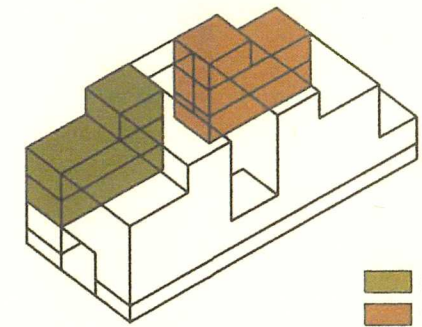

PH 201
PH 204

Pent House 201 / 204

132.26 m² privados
4.60 m² balcón
27.70 m² terraza
16.36 m² bodega semisótano
185.64 m² totales
2 cajones estacionamiento

- 1 Estancia
- 2 Comedor
- 3 Cocina
- 4 Cto. Lavado
- 5 Baño Visitas
- 6 Recamara Principal
- 7 Baño Principal
- 8 Recamara 2
- 9 Baño
- 10 Recamara 3
- 11 Baño 3
- 12 Roof Garden

0 1 2.5 5 7.5 10 12.5

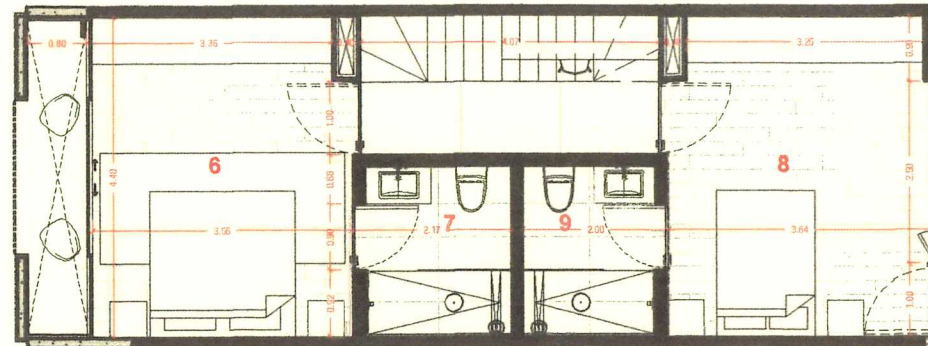

Pent House Nivel 1

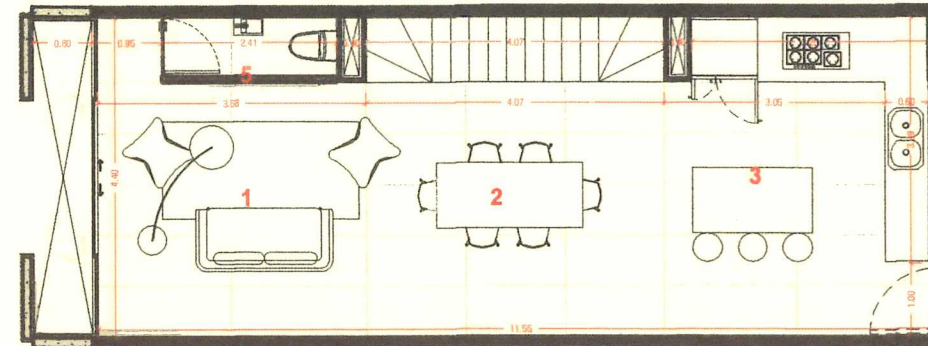

Pent House Nivel 2

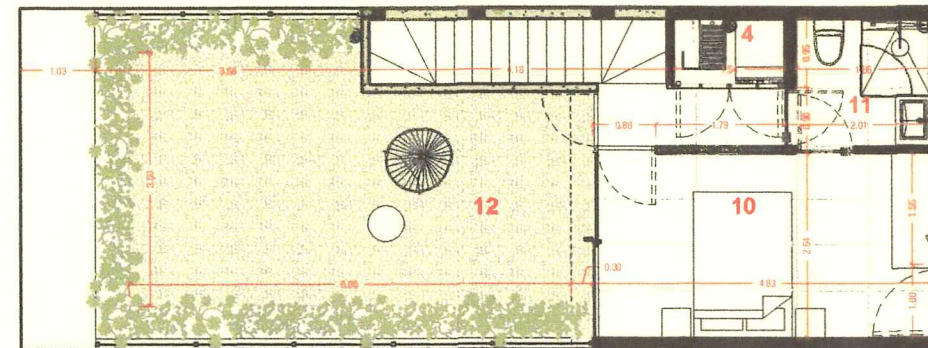

Pent House Nivel 3

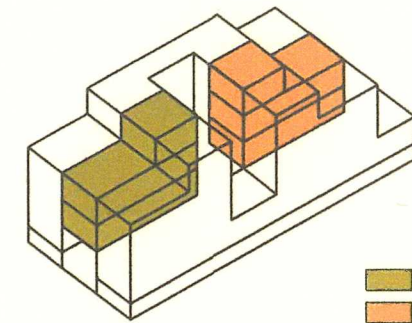

PH 202
PH 205

Pent House 202 / 205

131.23 m² privados
 4.54 m² balcón
 27.33 m² terraza
 4.92 m² bodega semisótano
 168.03 m² totales
 2 cajones estacionamiento

- 1 Estancia
- 2 Comedor
- 3 Cocina
- 4 Cto. Lavado
- 5 Baño Visitas
- 6 Recamara Principal
- 7 Baño Principal
- 8 Recamara 2
- 9 Baño
- 10 Recamara 3
- 11 Baño 3
- 12 Roof Garden

0 1 2.5 5 7.5 10

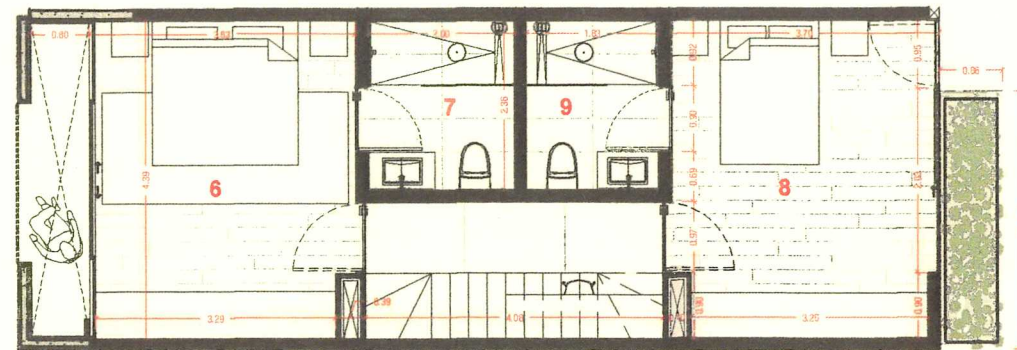

Pent House Nivel 1

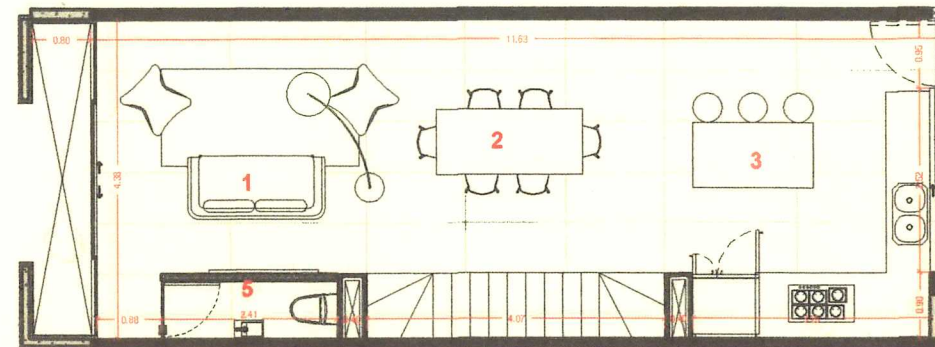

Pent House Nivel 2

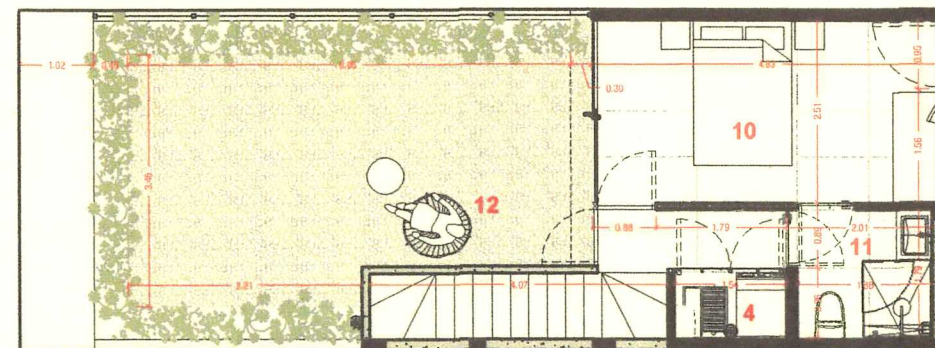

Pent House Nivel 3

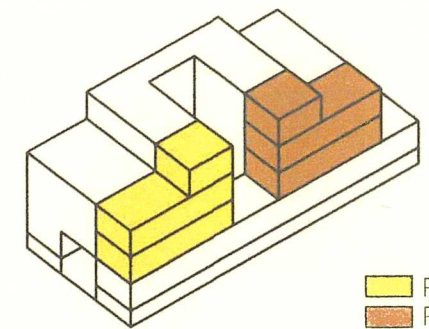

PH 203
PH 206

Pent House 203 / 206

133.00 m² privados
4.60 m² balcón
27.77 m² terraza
3.02 m² jardinera
4.88 m² bodega semisótano
173.28 m² totales
2 cajones estacionamiento

- 1 Estancia
- 2 Comedor
- 3 Cocina
- 4 Cto. Lavado
- 5 Baño Visitas
- 6 Recamara Principal
- 7 Baño Principal
- 8 Recamara 2
- 9 Baño
- 10 Recamara 3
- 11 Baño 3
- 12 Roof Garden

0 1 2.5 5 7.5 10







Shakespeare 83 | Tabla de Áreas

Propuesta	Depas	Depto	GH101	GH102	GH103	PH201	PH202	PH203	PH204	PH205	PH206
9D	9	Interiores	52.48	145.66	79.68	132.3	131.11	132.88	132.62	131.23	133.03
		Terraza Descubierta	4.01	39.31	32.97	-	-	-	-	-	-
		Terraza Cubierta	-	-	-	4.6	4.54	4.6	4.6	4.54	4.6
		Doble altura	-	-	-	2.3	2.27	2.3	2.3	2.27	2.3
		Roof Garden	-	-	-	27.7	27.53	27.68	27.81	27.33	27.77
		Cuarto de lavado	9.17	-	8.39	-	-	-	-	-	-
		Bodegas Semisolano *	-	-	-	16.36	9.54	9	8.69	4.92	4.88
		Cuarto de Servicio Semisolano	-	13.16	-	-	-	-	-	-	-
		Total	\$ 4,455,850.00	\$ 12,493,250.00	\$ 7,318,850.00	\$ 10,390,333.33	\$ 10,296,766.67	\$ 10,430,466.67	\$ 10,415,300.00	\$ 10,300,500.00	\$ 10,443,066.67
		Total (m2)	65.66	184.97	121.04	166.9	165.45	167.46	167.33	165.37	167.7

*Bodegas no se suman al costo del depto.

M2 TERRENO	453.46	Nivel c.d = "cubierta de"	m2 Construidos	m2 Comunas	m2 Privativos
AREA LIBRE M2 *	78.34	* sin balcones posteriores se cumple el 26% de AL			
AREA LIBRE %	17%				
DESPLANTE	330.92				
Semisótano	448.11 m2	8 cajones	448.11	87.91	360.2
Sótano	314.85 m2	8 cajones	391.69	34.61	346.65
Circulaciones	165.50 m2		381.26	34.61	346.65
		LOSA 1 (c.d. NSS)	188.64	34.61	154.03
		LOSA 2 (c.d. NGH)	167.83	13.8	154.03
		LOSA 3 (c.d. NPH1)	314.85	390.99	56.64
		LOSA 4 (c.d. NPH2)			
		LOSA 5 (c.d. NRG)			
		LOSA SEMI (c.d. NS)			
		GRAN TOTAL	1892.38	596.53	1418.2

FRR
ARQUITECTOS
REGISTRADOS

