



H. Ayuntamiento Constitucional de Progreso
2021 - 2024

DIRECCIÓN DEL CATASTRO DEL MUNICIPIO DE PROGRESO

DEPARTAMENTO: SECC. RÚST. DE PROGRESO DE CASTRO
NO. OFICIO: 7688
EXPEDIENTE: 9558

Relativo a su solicitud MUNICIPIO DE PROGRESO DE CASTRO

DIVISIÓN DE PREDIOS

31 DE MARZO DE 2022

C.C. FRANCISCO JAVIER DOMINGUEZ ROSADO, HERMINIO EMILIO DOMINGUEZ ROSADO, MARIA DEL SOCORRO CARMEN ROSADO Y DIAZ, ANDRES BOBADILLA MARTINEZ, MARIA LILIA RODRIGUEZ PECH, RAMIRO BOBADILLA MARTINEZ, LUIS ANSELMO DOMINGUEZ ROSADO, JOAQUIN JESUS DOMINGUEZ ROSADO, RITA MARIA DEL ROSARIO DOMINGUEZ ROSADO, RODRIGO TEC PAREDES, LILIA MERCEDES HERNANDEZ PECH, GUADALUPE PAREDES Y SULU, Y ANDRES BOBADILLA Y FLORES.

PRESENTE

Verificadas las dimensiones de las partes en que se dividirá EL PREDIO RUSTICO MARCADO EL TABLAJE 9558 DE LA LOCALIDAD DE CHICXULUB PUERTO DEL MUNICIPIO DE PROGRESO, YUCATÁN; los avalúos catastrales son como siguen:

PARTE No. 1 TABLAJE	NO.	9558	Superficie de Terreno	128,638.02 M2
			Superficie de Construcción	0.00 M2
			Avalúo Catastral	\$2,572,760.40
PARTE No. 2 TABLAJE	NO.	43866	Superficie de Terreno	140,000.00 M2
			Superficie de Construcción	0.00 M2
			Avalúo Catastral	\$2,800,000.00
PARTE No. 3 TABLAJE	NO.	43867	Superficie de Terreno	128,638.02 M2
			Superficie de Construcción	0.00 M2
			Avalúo Catastral	\$2,572,760.40
PARTE No. 4 TABLAJE	NO.	43868	Superficie de Terreno	128,638.02 M2
			Superficie de Construcción	0.00 M2
			Avalúo Catastral	\$2,572,760.40
PARTE No. 5 TABLAJE	NO.	43869	Superficie de Terreno	128,638.03 M2
			Superficie de Construcción	0.00 M2
			Avalúo Catastral	\$2,572,760.60
PARTE No. 6 TABLAJE	NO.	43870	Superficie de Terreno	128,638.03 M2
			Superficie de Construcción	0.00 M2
			Avalúo Catastral	\$2,572,760.60



H. Ayuntamiento Constitucional de Progreso
2021 - 2024

DIRECCIÓN DEL CATASTRO DEL MUNICIPIO DE PROGRESO

PARTE No. 7 TABLAJE	NO.	43871	Superficie de Terreno	128,638.03 M2
			Superficie de Construcción	0.00 M2
			Avalúo Catastral	\$2,572,760.60
PARTE No. 8 TABLAJE	NO.	43872	Superficie de Terreno	166,000.00 M2
			Superficie de Construcción	0.00 M2
			Avalúo Catastral	\$3,320,000.00
PARTE No. 9 TABLAJE	NO.	43873	Superficie de Terreno	128,638.03 M2
			Superficie de Construcción	0.00 M2
			Avalúo Catastral	\$2,572,760.60
PARTE No. 10 TABLAJE	NO.	43874	Superficie de Terreno	128,638.03 M2
			Superficie de Construcción	0.00 M2
			Avalúo Catastral	\$2,572,760.60
			VALOR TOTAL DE LOS PREDIOS	\$26,702,084.20

FUNDAMENTACIÓN: Ley de los Gobiernos de los Municipios del Estado de Yucatán Artículo 41, Ley que Crea el Instituto de Seguridad Jurídica Patrimonial del Estado de Yucatán Art. 127, 129, 133, 134, 145, 147, 169, 171 y 176, Reglamento que Crea el Instituto de Seguridad Jurídica Patrimonial del Estado de Yucatán Art. 5 y el Reglamento Interno de Catastro del Municipio de Progreso, Yucatán Art. 4 Fracción I, Art. 5 Fracción III, Art. 10 Fracción III, V, IX, X, XIII, XVI, XVII y XIX, Art. 14, Art. 30 y 32. Solo surtirá efectos de registro en esta dirección cumpliendo lo dispuesto en el Art. 22 del Reglamento del Catastro del Municipio de Progreso de Castro en vigor.

ATENTAMENTE
EL DIRECTOR DEL CATASTRO Y ZOFEMAT

MTRO. ALI YAMIL DIB MUÑOZ

ELABORÓ



DEPARTAMENTO TÉCNICO

TEC. MANUEL J. NÚÑEZ ESPINOSA

Se anexan planos sellados y aprobados por esta Dirección.

Ubicación: TABLAJE 9558

Población: CHICXULUB PUERTO

Municipio: PROG

PROPIETARIO ACTUAL

FRANCISCO JAVIER DOMINGUEZ ROSADO
HERMINIO EMILIO DOMINGUEZ ROSADO
MARIA DEL SOCORRO CARMEN ROSADO Y DIAZ
ANDRES BOBADILLA MARTINEZ
MARIA LILIA RODRIGUEZ PECH
RAMIRO BOBADILLA MARTINEZ
LUIS ANSELMO DOMIGUEZ ROSADO

JOAQUIN JESUS DOMINGUEZ ROSADO
RITA MARIA DEL ROSARIO DOMINGUEZ R
RODRIGO TEC PAREDES
LILIA MERCEDES HERNANDEZ PECH
GUADALUPE PAREDES YSULU
ANDRES BOBADILLA YFLORES

DATOS DE REGISTRO DEL PREDIO

Título de Propiedad: 1233

Fecha de Título: 23/12/2021

Título Emitido Por: NOTARIO NO. 23, LICENCIADO EN DERECHO LUIS ENRIQUE LÓPEZ MARTÍN

Número de Inscripción: 3016040

Folio Electrónico: 557615

MOTIVO DE EXPEDICIÓN

FRACCION 1 DE 2 DEL TABLAJE 9558

VALORES DEL PREDIO

Superficie del Terreno:	1,335,104.21 M2	Valor del Terreno:	\$ 26,702,084.26
Superficie Construida:	0.00 M2	Valor de las Construcciones:	\$0.00
		Valor Catastral:	\$26,702,084.26

Formuló:

ENNA ROSA YAM PEREZ



Director:

MTRO. ALI YAMIL DIB MUÑOZ

26/22

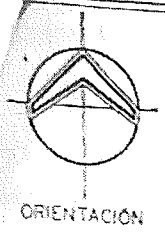

ORIENTACIÓN



LOCALIZACIÓN.

No. CAT.	
CALLE.	
NUMERO.	9558
COL.	
LOC.	CHICXULUB PTO.
MPIO.	PROGRESO
FOLIO.	
TOMO.	
LIB.	
DEST.	SOLAR
CAMB.	
ORIG.	
CLASE.	RUSTICO
REG.	
GRAV.	

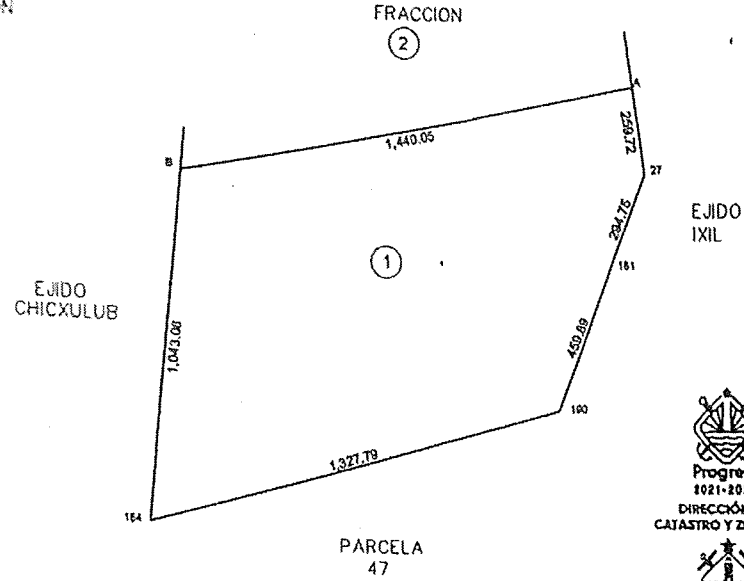

CUADRO DE CONSTRUCCION FRACC. 1

LADO		RUMBO	DISTANCIA	V	COORDENADAS T.M.E.	
EST	PV				Y	X
				A	2,351,668.1440	500,788.9025
A	B	S 78°43'24.87" W	1,440.048	B	2,351,386.5533	499,376.6547
B	164	S 05°54'31.13" W	1,043.083	164	2,350,349.0120	499,289.2770
164	190	N 74°15'54.38" E	1,327.786	190	2,350,709.0900	500,547.3070
190	161	N 21°33'58.05" E	459.890	161	2,351,136.7850	500,716.3510
161	27	N 21°33'57.92" E	284.716	27	2,351,410.8970	500,824.6920
27	A	N 07°55'13.55" W	259.725	A	2,351,668.1440	500,788.9025

SUPERFICIE = 1,335,104.21 m²

CONST.

ANTIGUO.
A-R
A-E
A-M
A-C
A-S
A-L
MODERNO.
M-R
M-E
M-M
M-C
M-S
M-L
INDUSTRIAL
I-F
I-M
I-S

PROPIETARIO.

ESCALA. 1:2000	DIBUJO M.J.N.E.
J. DE CARTOGRAFIA	PERITO VALUADOR
LEVANTÓ:	

J. DE PERITOS	J. DE PROCESOS
---------------	----------------

PROGRESO, YUC. A 22 DE JUNIO DE 2020

V x m	FTE	FDO	IRREG.	V.R.	SUPERFICIE	VALOR DE LA FRACCIÓN
					1,335,104.21	\$
						\$
						\$
						\$
VALOR TOTAL DEL TERRENO.						\$

GRUPO	TIPO	V x m	SUPERFICIE	VALOR DE LA FRACCIÓN
				\$
				\$
				\$
				\$
				\$
				\$
				\$
				\$
				\$
				\$
VALOR TOTAL DE CONSTRUCCIÓN.				\$
VALOR TOTAL DEL PRFDIO.				\$
VALOR CATASTRAL.				\$

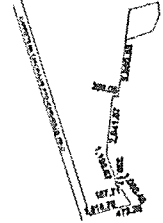
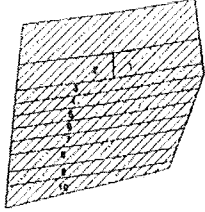
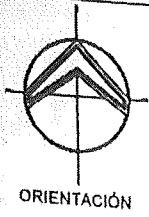

LOCALIZACIÓN.

No. CAT.	-
CALLE.	-
TABALJE	9558
COL.	
LOC.	CHICXULUB PTO.
MPIO.	PROGRESO
FOLIO.	
TOMO.	
LIB.	
DEST.	SOLAR
CAMB.	
ORIG.	
CLASE.	RUSTICO
REG.	
GRAV.	

TAB. CAT 31266

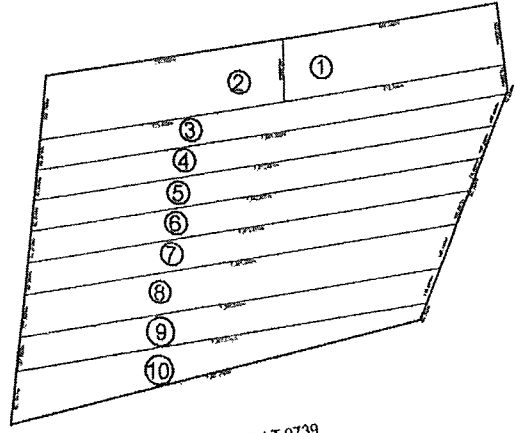

EJIDO IXIL

EJIDO IXIL

EJIDO CHICXULUB

TAB. CAT 9739



CONST.

ANTIGUO.

A-R
A-E
A-M
A-C
A-S
A-L

MODERNO.

M-R
M-E
M-M
M-C
M-S
M-L

INDUSTRIAL.

I-E
I-M
I-S

PROPIETARIO.

ESCALA. 1:20000	DIBUJÓ M.J.N.E
J. DE CARTOGRAFÍA	PERITO VALUADOR
LEVANTÓ:	

J. DE PERITOS	J. DE PROCESOS
---------------	----------------

PROGRESO, YUC. A 30 DE MARZO DE 2022

V x m ²	FTE	FDO	IRREG.	V.R.	SUPERFICIE.	VALOR DE LA FRACCIÓN
					1,335,104.21	\$
						\$
						\$
						\$
						\$
VALOR TOTAL DEL TERRENO.						\$

GRUPO	TIPO	V x m ²	SUPERFICIE.	VALOR DE LA FRACCIÓN
				\$
				\$
				\$
				\$
				\$
				\$
VALOR TOTAL DE CONSTRUCCIÓN.				\$
VALOR TOTAL DEL PREDIO.				\$
VALOR CATASTRAL.				\$

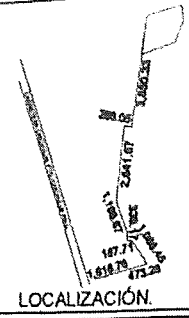
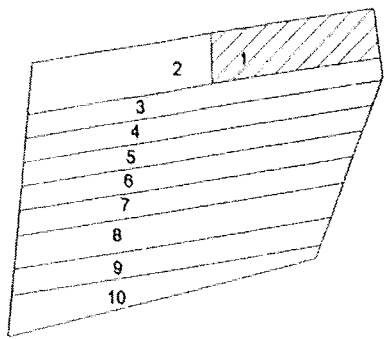
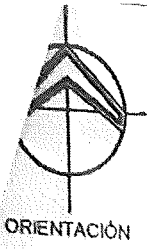

LOCALIZACIÓN.

No. CAT.	-
CALLE.	-
TABLAJE	9558
COL.	
LOC.	CHICXULUB PTO.
MPIO.	PROGRESO
FOLIO.	
TOMO.	
LIB.	
DEST.	SOLAR
CAMB.	
ORIG.	
CLASE.	RUSTICO
REG.	
GRAV.	

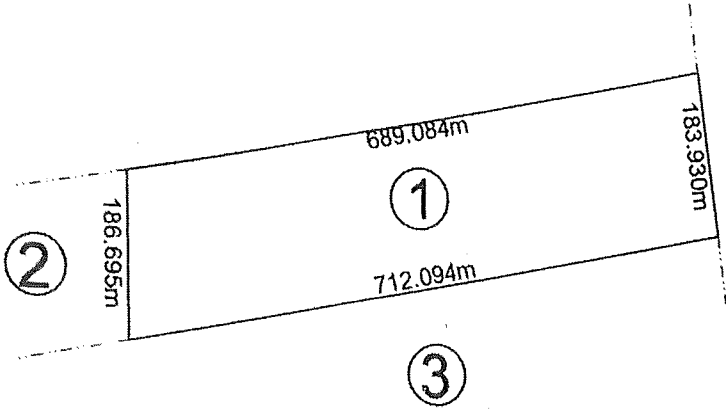

EJIDO IXIL



CONST.

ANTIGUO.	
A-R	
A-E	
A-M	
A-C	
A-S	
A-L	
MODERNO.	
M-R	
M-E	
M-M	
M-C	
M-S	
M-L	
INDUSTRIAL	
I-E	
I-M	
I-S	

PROPIETARIO.

ESCALA 1:7500	DIBUJÓ M.J.N.E
J. DE CARTOGRAFÍA	PERITO VALUADOR
LEVANTÓ	

J. DE PERITOS	J. DE PROCESOS

PROGRESO, YUC. A 30 DE MARZO DE 2022

V x m ²	FTE	FDO	IRREG.	V.R.	SUPERFICIE.	VALOR DE LA FRACCIÓN
					128,638.02	\$
						\$
						\$
						\$
						\$
VALOR TOTAL DEL TERRENO.						\$

GRUPO	TIPO	V x m ²	SUPERFICIE.	VALOR DE LA FRACCIÓN
				\$
				\$
				\$
				\$
				\$
				\$
VALOR TOTAL DE CONSTRUCCIÓN.				\$
VALOR TOTAL DEL PREDIO.				\$
VALOR CATASTRAL.				\$

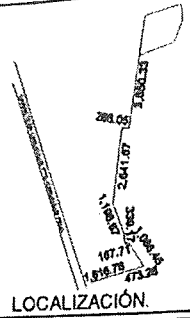
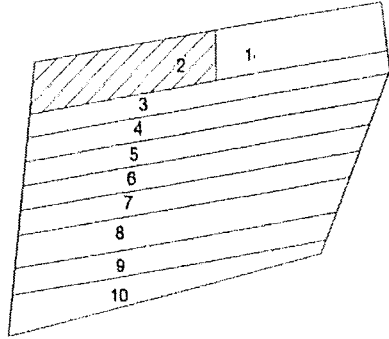
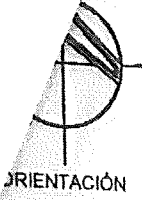

No. CAT.	-
CALLE.	-
TABLAJE	43866
COL.	
LOC.	CHICXULUB PTO.
MPIO.	PROGRESO
FOLIO.	
TOMO.	
LIB.	
DEST.	SOLAR
CAMB.	
ORIG.	
CLASE.	RUSTICO
REG.	
GRAV.	

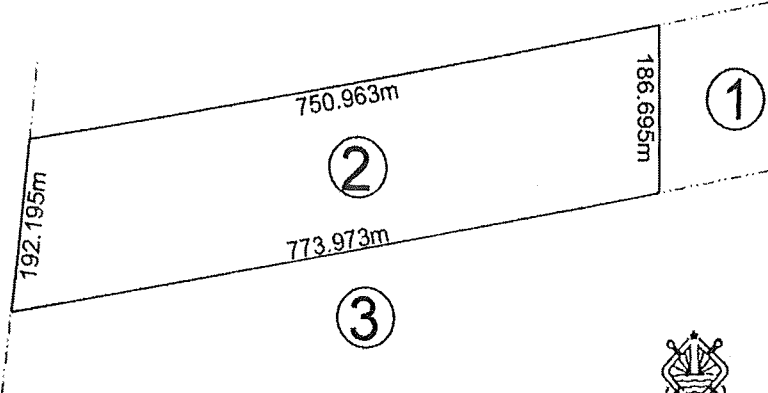

EJIDO CHICXULUB



CONST.	
ANTIGUO.	
A-R	
A-E	
A-M	
A-C	
A-S	
A-L	
MODERNO.	
M-R	
M-E	
M-M	
M-C	
M-S	
M-L	
INDUSTRIAL	
I-E	
I-M	
I-S	

PROPIETARIO.

ESCALA 1:7500	DIBUJÓ M.J.N.E
J. DE CARTOGRAFÍA	PERITO VALUADOR
LEVANTÓ:	

J. DE PERITOS	J. DE PROCESOS

PROGRESO, YUC. A 30 DE MARZO DE 2022

V x m ²	FTE	FDO	IRREG.	V.R.	SUPERFICIE.	VALOR DE LA FRACCIÓN
					140,000.00	\$
						\$
						\$
						\$
						\$
VALOR TOTAL DEL TERRENO.						\$

GRUPO	TIPO	V x m ²	SUPERFICIE.	VALOR DE LA FRACCIÓN
				\$
				\$
				\$
				\$
				\$
VALOR TOTAL DE CONSTRUCCIÓN.				\$
VALOR TOTAL DEL PREDIO.				\$
VALOR CATASTRAL				\$

ORIENTACIÓN

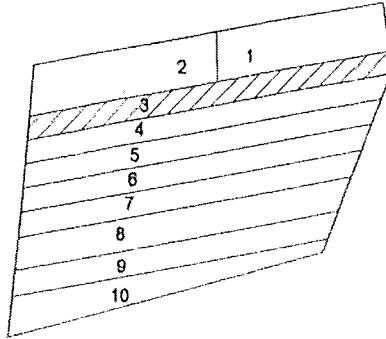

LOCALIZACIÓN.

No. CAT.	-
CALLE.	-
TABLAJE	43867
COL.	
LOC.	CHICXULUB PTO.
MPIO.	PROGRESO
FOLIO.	
TOMO.	
LIB.	
DEST.	SOLAR
CAMB.	
ORIG.	
CLASE.	RUSTICO
REG.	
GRAV.	

EJIDO CHICXULUB
89.978m

EJIDO
75.795m
72.254m

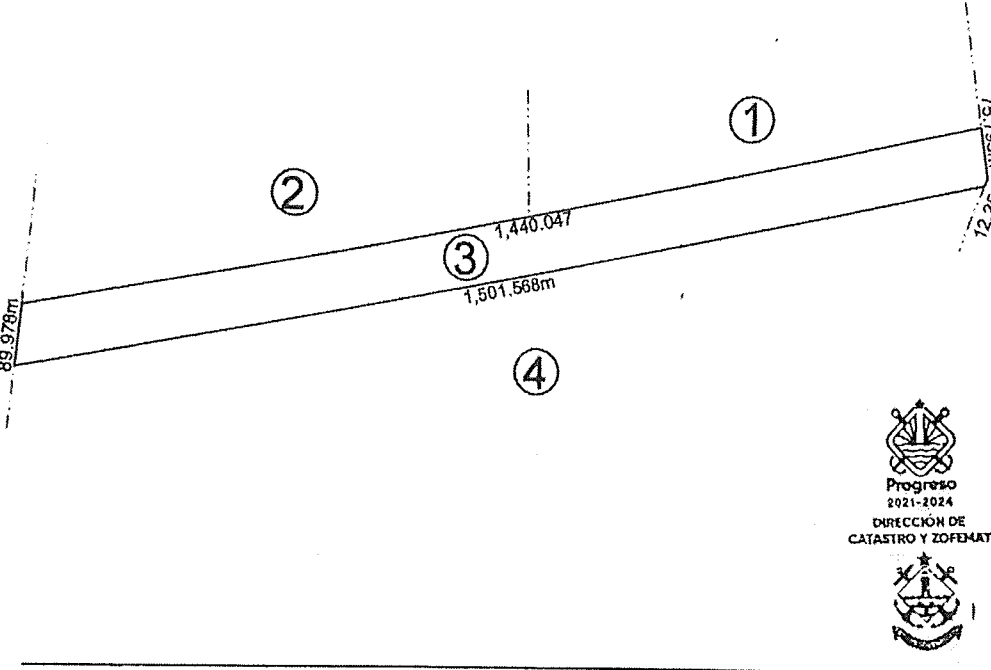

PROPIETARIO.

CONST.	
ANTIGUO.	
A-R	
A-E	
A-M	
A-C	
A-S	
A-L	
MODERNO.	
M-R	
M-E	
M-M	
M-C	
M-S	
M-L	
INDUSTRIAL	
I-E	
I-M	
I-S	

ESCALA. 1:10,000	DIBUJÓ M.J.N.E
J. DE CARTOGRAFÍA	PERITO VALUADOR
LEVANTÓ:	

J. DE PERITOS	J. DE PROCESOS

PROGRESO, YUC. A 30 DE MARZO DE 2022

V x m ²	FTE	FDO	IRREG.	V.R.	SUPERFICIE.	VALOR DE LA FRACCIÓN
					128,638.02	\$
						\$
						\$
						\$
VALOR TOTAL DEL TERRENO.						\$

GRUPO	TIPO	V x m ²	SUPERFICIE.	VALOR DE LA FRACCIÓN
				\$
				\$
				\$
				\$
VALOR TOTAL DE CONSTRUCCIÓN.				\$
VALOR TOTAL DEL PREDIO.				\$
VALOR CATASTRAL				\$

ORIENTACIÓN

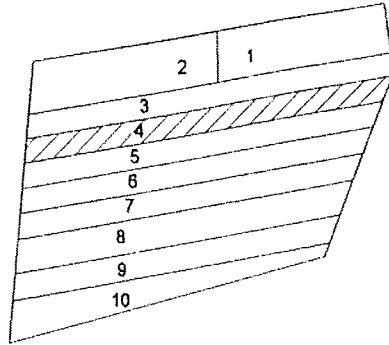

LOCALIZACIÓN.

No. CAT.	-
CALLE.	-
TABLAJE	43868
COL.	
LOC.	CHICXULUB PTO.
MPIO.	PROGRESO
FOLIO.	
TOMO.	
LIB.	
DEST.	SOLAR
CAMB.	
ORIG.	
CLASE.	RUSTICO
REG.	
GRAV.	

EJIDO CHICXULUB
90,550m

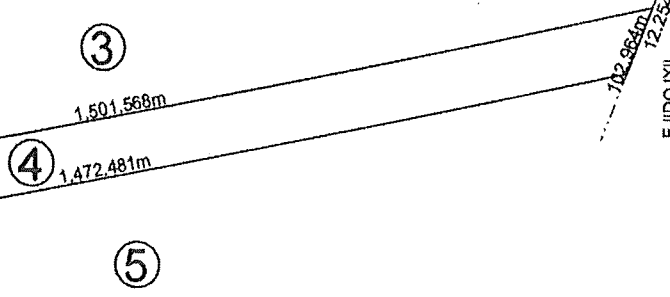

EJIDO IXIL



PROPIETARIO.

CONST.	
ANTIGUO.	
A-R	
A-E	
A-M	
A-C	
A-S	
A-L	
MODERNO.	
M-R	
M-E	
M-M	
M-C	
M-S	
M-L	
INDUSTRIAL	
I-E	
I-M	
I-S	

ESCALA 1:10,000.	DIBUJÓ M.J.N.E.
J. DE CARTOGRAFÍA	PERITO VALUADOR
LEVANTÓ:	

J. DE PERITOS	J. DE PROCESOS

PROGRESO, YUC. A 30 DE MARZO DE 2022

V x m ²	FTE	FDO	IRREG.	V.R.	SUPERFICIE	VALOR DE LA FRACCIÓN
					128,638.02	\$
						\$
						\$
						\$
						\$
						\$
VALOR TOTAL DEL TERRENO.						\$

GRUPO	TIPO	V x m ²	SUPERFICIE	VALOR DE LA FRACCIÓN
				\$
				\$
				\$
				\$
				\$
				\$
VALOR TOTAL DE CONSTRUCCIÓN				\$
VALOR TOTAL DEL PREDIO.				\$
VALOR CATASTRAL				\$



ORIENTACIÓN

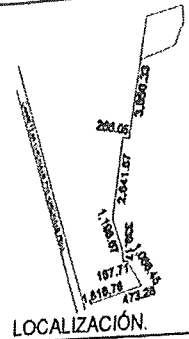
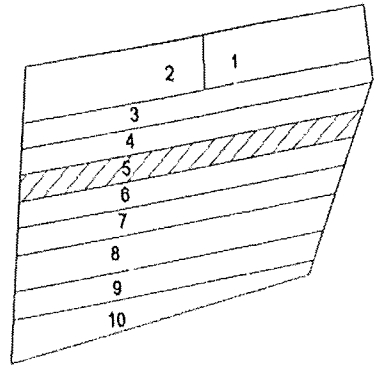

LOCALIZACIÓN.

No. CAT.	-
CALLE.	-
TABLAJE	43869
COL.	
LOC.	CHICXULUB PTO.
MPIO.	PROGRESO
FOLIO.	
TOMO.	
LIB.	
DEST.	SOLAR
CAMB.	
ORIG.	
CLASE.	RUSTICO
REG.	
GRAV.	

CONST.

ANTIGUO.	
A-R	
A-E	
A-M	
A-C	
A-S	
A-L	
MODERNO.	
M-R	
M-E	
M-M	
M-C	
M-S	
M-L	
INDUSTRIAL	
I-E	
I-M	
I-S	

EJIDO CHICXULUB
92.375m

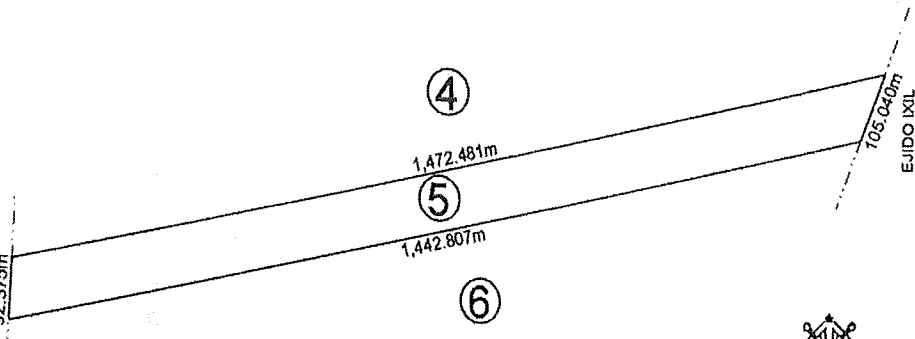

PROPIETARIO.

ESCALA 1:10,000	DIBUJÓ M.J.N.E
J. DE CARTOGRAFÍA	PERITO VALUADOR
LEVANTÓ:	
J. DE PERITOS	J. DE PROCESOS
PROGRESO, YUC. A 30 DE MARZO DE 2022	

V x m ²	FTE	FDO	IRREG	V.R.	SUPERFICIE.	VALOR DE LA FRACCIÓN
					128,638.03	\$
						\$
						\$
						\$
VALOR TOTAL DEL TERRENO.						\$

GRUPO	TIPO	V x m ²	SUPERFICIE.	VALOR DE LA FRACCIÓN
				\$
				\$
				\$
				\$
				\$
VALOR TOTAL DE CONSTRUCCIÓN				\$
VALOR TOTAL DEL PREDIO.				\$
VALOR CATASTRAL				\$

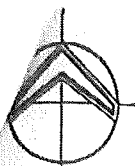

ORIENTACIÓN

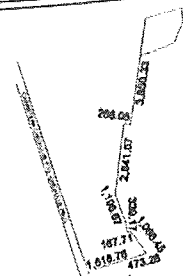
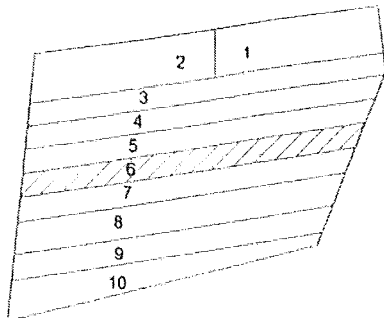

LOCALIZACIÓN

No. CAT.	-
CALLE	-
TABLAJE	43870
COL.	
LOC.	CHICXULUB PTO.
MPIO.	PROGRESO
FOLIO.	
TOMO.	
LIB.	
DEST.	SOLAR
CAMB.	
ORIG.	
CLASE.	RUSTICO
REG.	
GRAV.	

EJIDO CHICXULUB

94.315m

⑤

1,442.807m

⑥

1,412.511m

⑦

32.758m
74.738m
EJIDO IXIL

CONST.

ANTIGUO.

- A-R
- A-E
- A-M
- A-C
- A-S
- A-L

MODERNO.

- M-R
- M-E
- M-M
- M-C
- M-S
- M-L

INDUSTRIAL

- I-E
- I-M
- I-S



PROPIETARIO.

ESCALA 1:10,000	DIBUJÓ M.J.N.E
J. DE CARTOGRAFÍA	PERITO VALUADOR
LEVANTÓ:	

J. DE PERITOS	J. DE PROCESOS

PROGRESO, YUC A 30 DE MARZO DE 2022

V x m ²	FTE	FDO	IRREG.	V.R	SUPERFICIE	VALOR DE LA FRACCIÓN
					128,638.03	\$
						\$
						\$
						\$
VALOR TOTAL DEL TERRENO.						\$

GRUPO	TIPO	V x m ²	SUPERFICIE	VALOR DE LA FRACCIÓN
				\$
				\$
				\$
				\$
				\$
VALOR TOTAL DE CONSTRUCCIÓN.				\$
VALOR TOTAL DEL PREDIO.				\$
VALOR CATASTRAL				\$

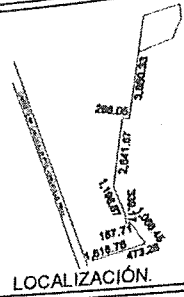
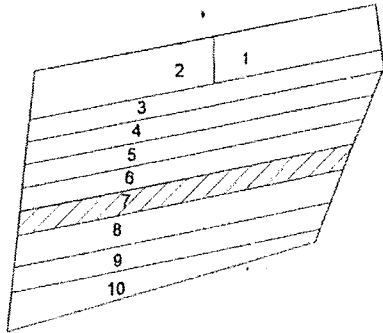
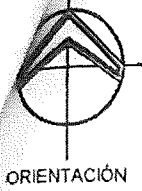

EJIDO CHICXULUB
96.383m

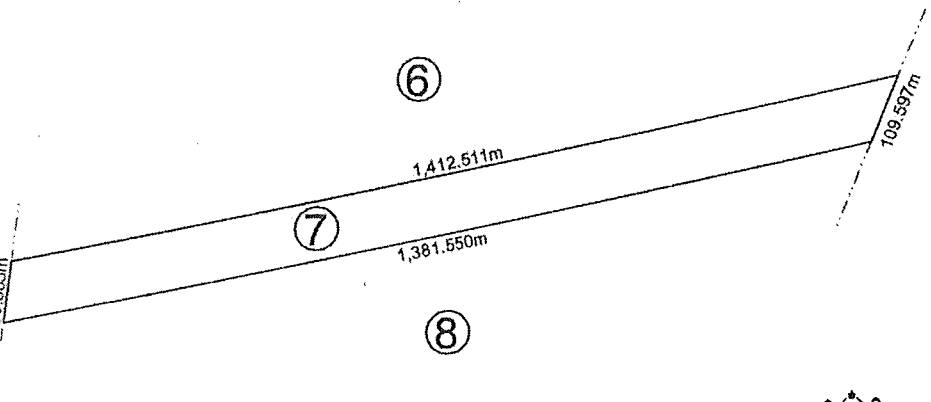

EJIDO IXIL



PROPIETARIO

No. CAT.	-
CALLE	-
TABLAJE	43871
COL.	-
LOC.	CHICXULUB PTO.
MPIO.	PROGRESO
FOLIO.	-
TOMO.	-
LIB.	-
DEST.	SOLAR
CAMB.	-
ORIG.	-
CLASE.	RUSTICO
REG.	-
GRAV.	-

CONST.	
ANTIGUO.	
A-R	
A-E	
A-M	
A-C	
A-S	
A-L	
MODERNO.	
M-R	
M-E	
M-M	
M-C	
M-S	
M-L	
INDUSTRIAL	
I-E	
I-M	
I-S	

ESCALA 1:10,000	DIBUJÓ M.J.N.E
J. DE CARTOGRAFÍA	PERITO VALUADOR
LEVANTÓ.	

J. DE PERITOS	J. DE PROCESOS

PROGRESO, YUC. A 30 DE MARZO DE 2022

V x m ²	FTE	FDO	IRREG.	V.R.	SUPERFICIE.	VALOR DE LA FRACCIÓN
					128,638.03	\$
						\$
						\$
						\$
VALOR TOTAL DEL TERRENO.						\$

GRUPO	TIPO	V x m ²	SUPERFICIE.	VALOR DE LA FRACCIÓN
				\$
				\$
				\$
				\$
				\$
VALOR TOTAL DE CONSTRUCCIÓN.				\$
VALOR TOTAL DEL PREDIO.				\$
VALOR CATASTRAL.				\$

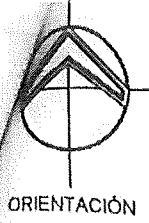

ORIENTACIÓN

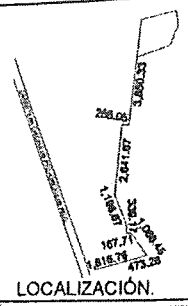
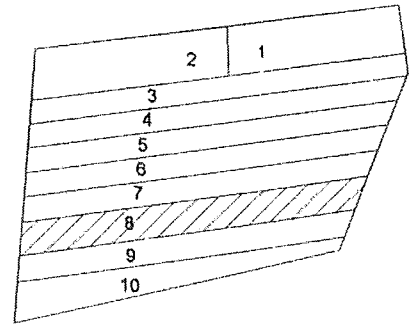

LOCALIZACIÓN.

No. CAT.	-
CALLE.	-
TABLAJE	43872
COL.	
LOC.	CHICXULUB PTO.
MPIO.	PROGRESO
FOLIO.	
TOMO.	
LIB.	
DEST.	SOLAR
CAMB.	
ORIG.	
CLASE.	RUSTICO
REG.	
GRAV.	

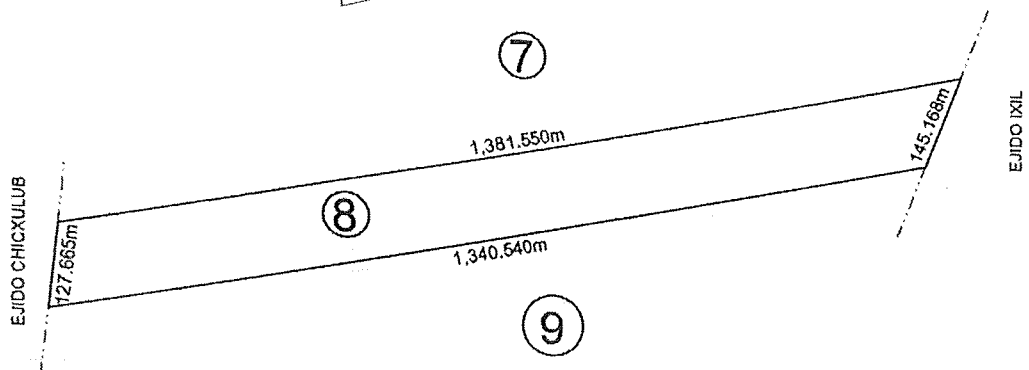

CONST.	
ANTIGUO.	
A-R	
A-E	
A-M	
A-C	
A-S	
A-L	
MODERNO.	
M-R	
M-E	
M-M	
M-C	
M-S	
M-L	
INDUSTRIAL	
I-E	
I-M	
I-S	

PROPIETARIO.

ESCALA 1:10,000	DIBUJÓ M.J.N.E
J. DE CARTOGRAFÍA	PERITO VALUADOR
LEVANTÓ:	

J. DE PERITOS	J. DE PROCESOS

PROGRESO, YUC. A 30 DE MARZO DE 2022

V x m ²	FTE	FDO	IRREG.	V.R.	SUPERFICIE	VALOR DE LA FRACCIÓN
					166,000.00	\$
						\$
						\$
						\$
						\$
VALOR TOTAL DEL TERRENO.						\$

GRUPO	TIPO	V x m ²	SUPERFICIE	VALOR DE LA FRACCIÓN
				\$
				\$
				\$
				\$
				\$
VALOR TOTAL DE CONSTRUCCIÓN.				\$
VALOR TOTAL DEL PREDIO.				\$
VALOR CATASTRAL				\$

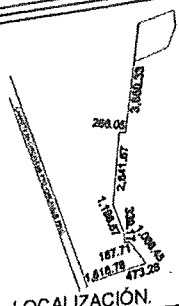
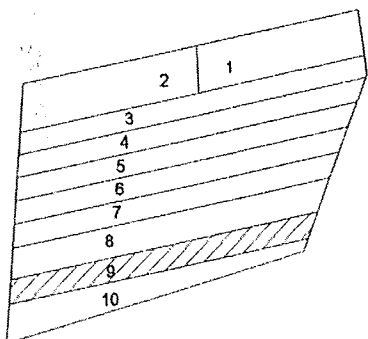

No. CAT.	-
CALLE.	-
TABLAJE	43873
COL.	-
LOC.	CHICXULUB PTO.
MPIO.	PROGRESO
FOLIO.	-
TOMO.	-
LIB.	-
DEST.	SOLAR
CAMB.	-
ORIG.	-
CLASE.	RUSTICO
REG.	-
GRAV.	-

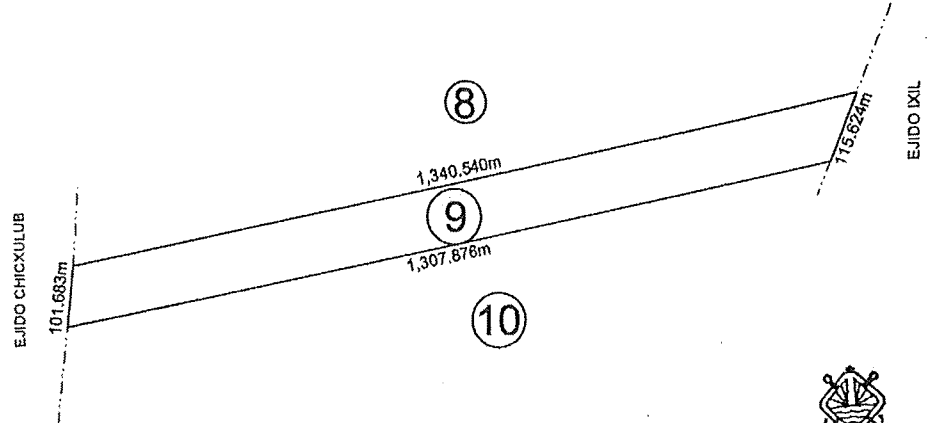

PROPIETARIO.

CONST.	
ANTIGUO.	
A-R	
A-E	
A-M	
A-C	
A-S	
A-L	
MODERNO.	
M-R	
M-E	
M-M	
M-C	
M-S	
M-L	
INDUSTRIAL	
I-E	
I-M	
I-S	

ESCALA. 1:10,000	DIBUJÓ M.J.N.E
J. DE CARTOGRAFÍA	PERITO VALUADOR
LEVANTÓ:	
J. DE PERITOS	J. DE PROCESOS
PROGRESO, YUC. A 30 DE MARZO DE 2022	

V x m ²	FTE	FDO	IRREG.	V.R.	SUPERFICIE.	VALOR DE LA FRACCIÓN
					128,638.03	\$
						\$
						\$
						\$
VALOR TOTAL DEL TERRENO.						\$

GRUPO	TIPO	V x m ²	SUPERFICIE.	VALOR DE LA FRACCIÓN
				\$
				\$
				\$
				\$
VALOR TOTAL DE CONSTRUCCIÓN.				\$
VALOR TOTAL DEL PREDIO				\$
VALOR CATASTRAL				\$

ORIENTACIÓN

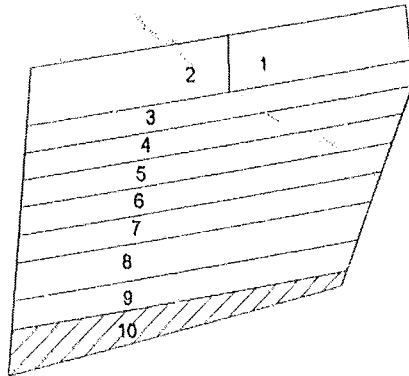

LOCALIZACIÓN

No. CAT.	-
CALLE.	-
TABLAJE	43874
COL.	-
LOC.	CHICXULUB PTO.
MPIO.	PROGRESO
FOLIO.	-
TOMO.	-
LIB.	-
DEST.	SOLAR
CAMB.	-
ORIG.	-
CLASE.	RUSTICO
REG.	-
GRAV.	-

EJIDO CHICXULUB

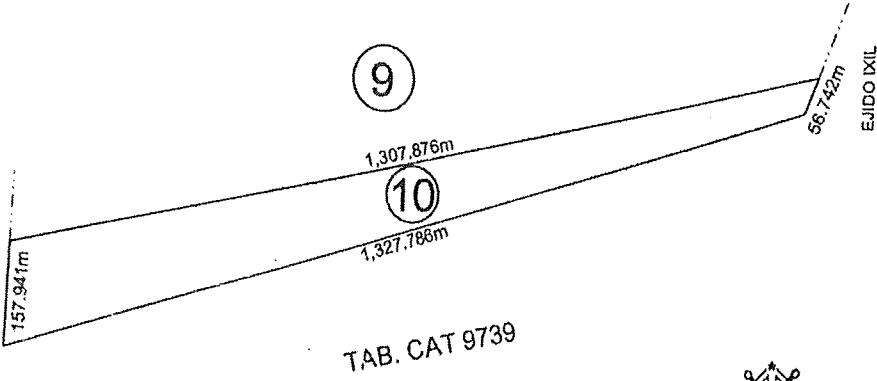

TAB. CAT 9739



CONST.

ANTIGUO.	
A-R	
A-E	
A-M	
A-C	
A-S	
A-L	
MODERNO.	
M-R	
M-E	
M-M	
M-C	
M-S	
M-L	
INDUSTRIAL	
I-E	
I-M	
I-S	



PROPIETARIO.

ESCALA 1:10,000	DIBUJÓ M.J.N.E
J. DE CARTOGRAFÍA	PERITO VALUADOR
LEVANTÓ:	
J. DE PERITOS	J. DE PROCESOS
PROGRESO, YUC. A 30 DE MARZO DE 2022	

V x m ²	FTE	FDO	IRREG.	V.R.	SUPERFICIE.	VALOR DE LA FRACCIÓN
					128,638.03	\$
						\$
						\$
						\$
VALOR TOTAL DEL TERRENO.						\$

GRUPO	TIPO	V x m ²	SUPERFICIE.	VALOR DE LA FRACCIÓN
				\$
				\$
				\$
				\$
				\$
VALOR TOTAL DE CONSTRUCCIÓN.				\$
VALOR TOTAL DEL PREDIO.				\$
VALOR CATASTRAL.				\$

