



FEATURES & AMENITIES

DETAILS OF A LIFE WELL LIVED

Personalized services, including a 24-hour concierge, are complemented by a host of amenities at Mr. C Residences Coconut Grove.

Arrival Experience

- Covered Valet Drop-Off
- Reception and Concierge Desk
- Lobby Lounge
- Mail & Package Rooms
- Curated Art Pieces in Lobby
- Lush Landscaping

Dining & Retail

- Signature Café
- Specialty Gourmet Market
- Wellness Lounge and Juice Bar
- Private Bellini Bar on Pool Deck
- Poolside Food and Beverage Service
- In-Home Delivery from Café

Services

- Concierge Reception
- Butler Service
- Lifestyle and Nautical Concierge
- 24-Hour Doorman & Security
- 24-Hour Valet
- Mr. C Property Management Team
- Housekeeping Service Available

Residence Features

- Open Floor Plan Layouts
- 11-Foot Ceilings
- Floor-to-Ceiling Glass
- Bayshore, City and Grove Views
- Private Outdoor Terraces
- Italian Terrazzo & Quartz Countertops
- Italian Cabinetry
- European Porcelain Tile Floors
- Custom Kitchen Island

- Premium Appliances Subzero Wolf
- Solid Core Interior Wood Doors
- Pre-Wired for High-Speed Internet

Body & Mind Wellness Center

- Whole-Body Fitness Zones
- Stretch, Cardio, Weights & Fitness
- Personal Trainers & Specialty Classes Available
- Wellness Lounge w/Juice Bar
- Indoor Yoga Studio
- Peloton Studio
- Men's and Women's Locker Rooms
- Signature Spa with Treatment Rooms
- Steam & Sauna

Bayshore Owners' Club

- Bayshore Club Pool w/Sundeck
- Poolside Food & Beverage Service
- Cabanas w/Towel Service
- Pool Bar & Event Lounge
- Garden-Level Lap Pool
- Billiards Room
- Library & Screen Lounge
- Little C's Learning & Adventure Lab
- Teen Game Lounge
- Business Lounge w/Meeting Rooms

Mr. C Sales Gallery
2640 S. Bayshore Drive
Coconut Grove, FL 33133

MRCGrove.com

COME HOME TO MR. C

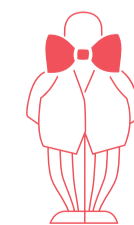

RESIDENCE
01

Exclusive Sales and Marketing by
Douglas Elliman Development Marketing

Terra

This project is being developed by CG Summer Investments, LLP, a Florida limited liability partnership ("Developer"), which has a limited right to use the trademarked names and logos of Terra and Mr. C. Any and all statements, disclosures and/or representations shall be deemed made by Developer and not by Terra and/or Mr. C, and you agree to look solely to Developer (and not to Terra, Mr. C and/or any of their affiliates) with respect to any and all matters relating to the sales and marketing and/or development of the project. ORAL REPRESENTATIONS CANNOT BE RELIED UPON AS CORRECTLY STATING THE REPRESENTATIONS OF THE DEVELOPER. FOR CORRECT REPRESENTATIONS, MAKE REFERENCE TO THIS BROCHURE AND TO THE DOCUMENTS REQUIRED BY SECTION 718.503, FLORIDA STATUTES, TO BE FURNISHED BY A DEVELOPER TO A BUYER OR LESSEE. These materials are not intended to be an offer to sell, or solicitation to buy a unit in the condominium. Such an offering shall only be made pursuant to the prospectus (offering circular) for the condominium and no statements should be relied upon unless made in the prospectus or in the applicable purchase agreement. In no event shall any solicitation, offer or sale of a unit in the condominium be made in, or to residents of, any state or country in which such activity would be unlawful.

Mr. C
RESIDENCES
COCONUT GROVE, FL

BY
IGNAZIO
AND
MAGGIO
CIPRIANI

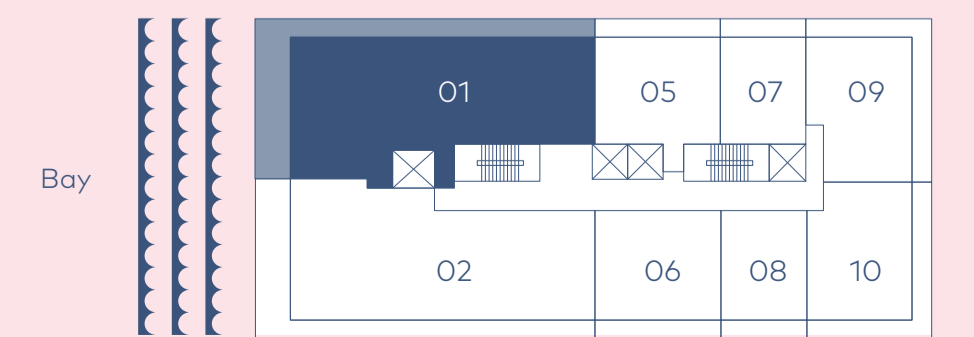
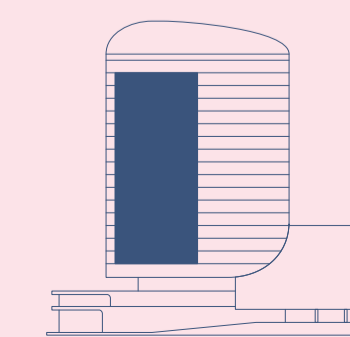
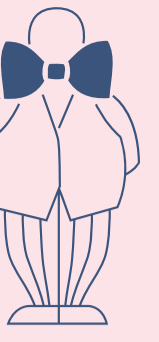



FEATURES & AMENITIES

DETAILS OF A LIFE WELL LIVED

Personalized services, including a 24-hour concierge, are complemented by a host of amenities at Mr. C Residences Coconut Grove.

Arrival Experience

- Covered Valet Drop-Off
- Reception and Concierge Desk
- Lobby Lounge
- Mail & Package Rooms
- Curated Art Pieces in Lobby
- Lush Landscaping

Dining & Retail

- Signature Café
- Specialty Gourmet Market
- Wellness Lounge and Juice Bar
- Private Bellini Bar on Pool Deck
- Poolside Food and Beverage Service
- In-Home Delivery from Café

Services

- Concierge Reception
- Butler Service
- Lifestyle and Nautical Concierge
- 24-Hour Doorman & Security
- 24-Hour Valet
- Mr. C Property Management Team
- Housekeeping Service Available

Residence Features

- Open Floor Plan Layouts
- 11-Foot Ceilings
- Floor-to-Ceiling Glass
- Bayshore, City and Grove Views
- Private Outdoor Terraces
- Italian Terrazzo & Quartz Countertops
- Italian Cabinetry
- European Porcelain Tile Floors
- Custom Kitchen Island

- Premium Appliances Subzero Wolf
- Solid Core Interior Wood Doors
- Pre-Wired for High-Speed Internet

Body & Mind Wellness Center

- Whole-Body Fitness Zones
- Stretch, Cardio, Weights & Fitness
- Personal Trainers & Specialty Classes Available
- Wellness Lounge w/Juice Bar
- Indoor Yoga Studio
- Peloton Studio
- Men's and Women's Locker Rooms
- Signature Spa with Treatment Rooms
- Steam & Sauna

Bayshore Owners' Club

- Bayshore Club Pool w/Sundeck
- Poolside Food & Beverage Service
- Cabanas w/Towel Service
- Pool Bar & Event Lounge
- Garden-Level Lap Pool
- Billiards Room
- Library & Screen Lounge
- Little C's Learning & Adventure Lab
- Teen Game Lounge
- Business Lounge w/Meeting Rooms

Mr. C Sales Gallery
2640 S. Bayshore Drive
Coconut Grove, FL 33133

MRCGrove.com

COME HOME TO MR. C

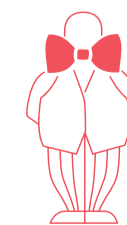

RESIDENCE
02

Exclusive Sales and Marketing by
Douglas Elliman Development Marketing

Terra

This project is being developed by CG Summer Investments, LLP, a Florida limited liability partnership ("Developer"), which has a limited right to use the trademarked names and logos of Terra and Mr. C. Any and all statements, disclosures and/or representations shall be deemed made by Developer and not by Terra and/or Mr. C, and you agree to look solely to Developer (and not to Terra, Mr. C and/or any of their affiliates) with respect to any and all matters relating to the sales and marketing and/or development of the project. ORAL REPRESENTATIONS CANNOT BE RELIED UPON AS CORRECTLY STATING THE REPRESENTATIONS OF THE DEVELOPER. FOR CORRECT REPRESENTATIONS, MAKE REFERENCE TO THIS BROCHURE AND TO THE DOCUMENTS REQUIRED BY SECTION 718.503, FLORIDA STATUTES, TO BE FURNISHED BY A DEVELOPER TO A BUYER OR LESSEE. These materials are not intended to be an offer to sell, or solicitation to buy a unit in the condominium. Such an offering shall only be made pursuant to the prospectus (offering circular) for the condominium and no statements should be relied upon unless made in the prospectus or in the applicable purchase agreement. In no event shall any solicitation, offer or sale of a unit in the condominium be made in, or to residents of, any state or country in which such activity would be unlawful.

Mr. C
RESIDENCES
COCONUT GROVE, FL

BY
IGNAZIO
AND
MAGGIO
CIPRIANI

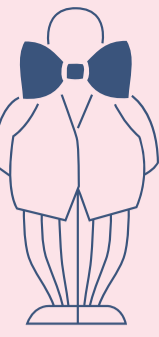

FEATURES
3 Bedrooms
4 Bathrooms
Powder Room

INDOOR AREA
2623 ft²
244 m²

OUTDOOR LIVING
815 ft²
76 m²

TOTAL AREA
3438 ft²
319 m²



Exclusive Sales and Marketing by Douglas Elliman Development Marketing

Stated square footages and dimensions are measured to the exterior boundaries of the exterior walls and the centerline of interior demising walls and in fact vary from the square footage and dimensions that would be determined by using the description and definition of the "Unit" set forth in the Declaration (which generally only includes the interior airspace between the perimeter walls and excludes all interior structural components and other common elements). This method is generally used in sales materials and is provided to allow a prospective buyer to compare the Units with units in other condominium projects that utilize the same method. Measurements of rooms are generally taken at the farthest points of each given room (as if the room were a perfect rectangle), without regard for any cutouts or variations. Accordingly, the area of the actual room will typically be smaller than the product obtained by multiplying the stated length and width. All dimensions are estimates which will vary with actual construction, and all floor plans, specifications and other development plans are subject to change and will not necessarily accurately reflect the final plans and specifications for the development.

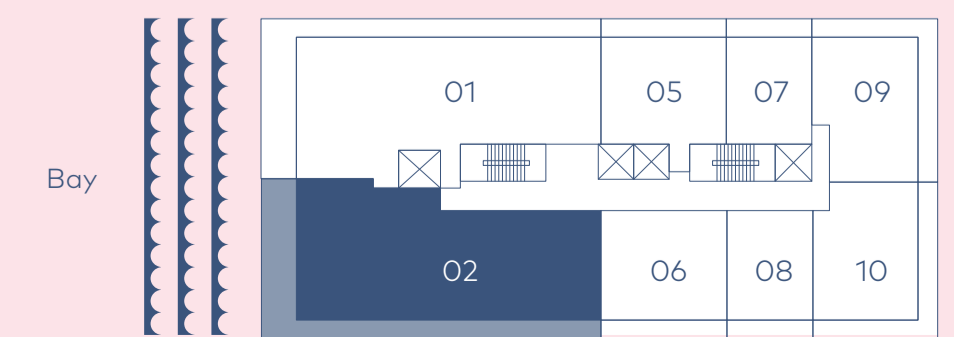
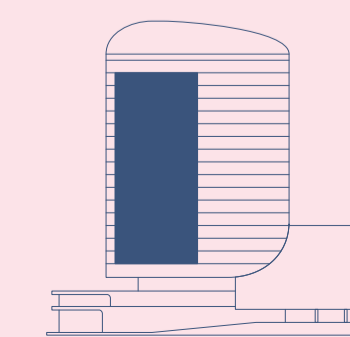



FEATURES & AMENITIES

DETAILS OF A LIFE WELL LIVED

Personalized services, including a 24-hour concierge, are complemented by a host of amenities at Mr. C Residences Coconut Grove.

Arrival Experience

- Covered Valet Drop-Off
- Reception and Concierge Desk
- Lobby Lounge
- Mail & Package Rooms
- Curated Art Pieces in Lobby
- Lush Landscaping

Dining & Retail

- Signature Café
- Specialty Gourmet Market
- Wellness Lounge and Juice Bar
- Private Bellini Bar on Pool Deck
- Poolside Food and Beverage Service
- In-Home Delivery from Café

Services

- Concierge Reception
- Butler Service
- Lifestyle and Nautical Concierge
- 24-Hour Doorman & Security
- 24-Hour Valet
- Mr. C Property Management Team
- Housekeeping Service Available

Residence Features

- Open Floor Plan Layouts
- 11-Foot Ceilings
- Floor-to-Ceiling Glass
- Bayshore, City and Grove Views
- Private Outdoor Terraces
- Italian Terrazzo & Quartz Countertops
- Italian Cabinetry
- European Porcelain Tile Floors
- Custom Kitchen Island

- Premium Appliances Subzero Wolf
- Solid Core Interior Wood Doors
- Pre-Wired for High-Speed Internet

Body & Mind Wellness Center

- Whole-Body Fitness Zones
- Stretch, Cardio, Weights & Fitness
- Personal Trainers & Specialty Classes Available
- Wellness Lounge w/Juice Bar
- Indoor Yoga Studio
- Peloton Studio
- Men's and Women's Locker Rooms
- Signature Spa with Treatment Rooms
- Steam & Sauna

Bayshore Owners' Club

- Bayshore Club Pool w/Sundeck
- Poolside Food & Beverage Service
- Cabanas w/Towel Service
- Pool Bar & Event Lounge
- Garden-Level Lap Pool
- Billiards Room
- Library & Screen Lounge
- Little C's Learning & Adventure Lab
- Teen Game Lounge
- Business Lounge w/Meeting Rooms

Mr. C Sales Gallery
2640 S. Bayshore Drive
Coconut Grove, FL 33133

MRCGrove.com

COME HOME TO MR. C

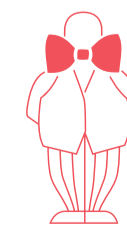

RESIDENCE
05

Exclusive Sales and Marketing by
Douglas Elliman Development Marketing

Terra

This project is being developed by CG Summer Investments, LLP, a Florida limited liability partnership ("Developer"), which has a limited right to use the trademarked names and logos of Terra and Mr. C. Any and all statements, disclosures and/or representations shall be deemed made by Developer and not by Terra and/or Mr. C, and you agree to look solely to Developer (and not to Terra, Mr. C and/or any of their affiliates) with respect to any and all matters relating to the sales and marketing and/or development of the project. ORAL REPRESENTATIONS CANNOT BE RELIED UPON AS CORRECTLY STATING THE REPRESENTATIONS OF THE DEVELOPER. FOR CORRECT REPRESENTATIONS, MAKE REFERENCE TO THIS BROCHURE AND TO THE DOCUMENTS REQUIRED BY SECTION 718.503, FLORIDA STATUTES, TO BE FURNISHED BY A DEVELOPER TO A BUYER OR LESSEE. These materials are not intended to be an offer to sell, or solicitation to buy a unit in the condominium. Such an offering shall only be made pursuant to the prospectus (offering circular) for the condominium and no statements should be relied upon unless made in the prospectus or in the applicable purchase agreement. In no event shall any solicitation, offer or sale of a unit in the condominium be made in, or to residents of, any state or country in which such activity would be unlawful.

Mr. C
RESIDENCES
COCONUT GROVE, FL

BY
IGNAZIO
AND
MAGGIO
CIPRIANI

RESIDENCE
05

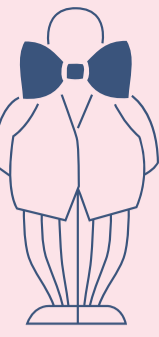

FEATURES

2 Bedrooms
2 Bathrooms

INDOOR AREA

1016 ft²
94 m²

OUTDOOR LIVING

170 ft²
16 m²

TOTAL AREA

1186 ft²
110 m²

Exclusive Sales and Marketing by Douglas Elliman Development Marketing

Stated square footages and dimensions are measured to the exterior boundaries of the exterior walls and the centerline of interior demising walls and in fact vary from the square footage and dimensions that would be determined by using the description and definition of the "Unit" set forth in the Declaration (which generally only includes the interior airspace between the perimeter walls and excludes all interior structural components and other common elements). This method is generally used in sales materials and is provided to allow a prospective buyer to compare the Units with units in other condominium projects that utilize the same method. Measurements of rooms set forth on this floor plan are generally taken at the farthest points of each given room (as if the room were a perfect rectangle), without regard for any cutouts or variations. Accordingly, the area of the actual room will typically be smaller than the product obtained by multiplying the stated length and width. All dimensions are estimates which will vary with actual construction, and all floor plans, specifications and other development plans are subject to change and will not necessarily accurately reflect the final plans and specifications for the development.

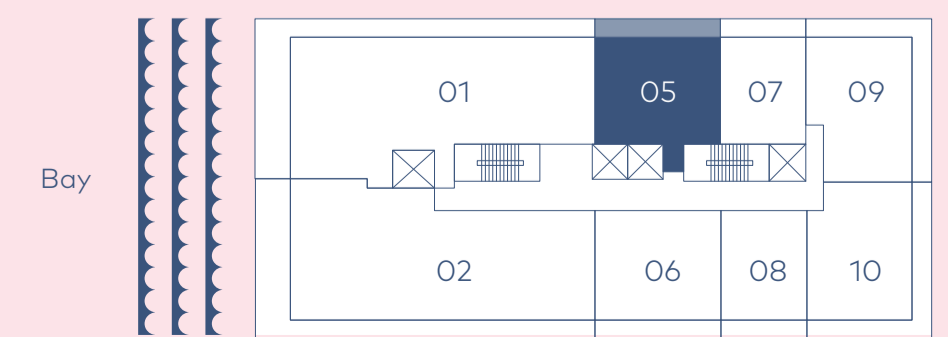
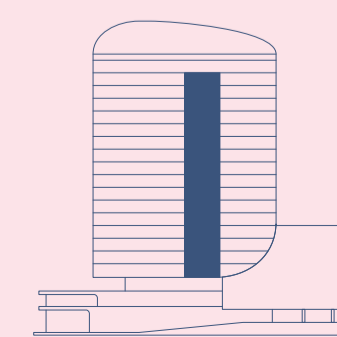



FEATURES & AMENITIES

DETAILS OF A LIFE WELL LIVED

Personalized services, including a 24-hour concierge, are complemented by a host of amenities at Mr. C Residences Coconut Grove.

Arrival Experience

- Covered Valet Drop-Off
- Reception and Concierge Desk
- Lobby Lounge
- Mail & Package Rooms
- Curated Art Pieces in Lobby
- Lush Landscaping

Dining & Retail

- Signature Café
- Specialty Gourmet Market
- Wellness Lounge and Juice Bar
- Private Bellini Bar on Pool Deck
- Poolside Food and Beverage Service
- In-Home Delivery from Café

Services

- Concierge Reception
- Butler Service
- Lifestyle and Nautical Concierge
- 24-Hour Doorman & Security
- 24-Hour Valet
- Mr. C Property Management Team
- Housekeeping Service Available

Residence Features

- Open Floor Plan Layouts
- 11-Foot Ceilings
- Floor-to-Ceiling Glass
- Bayshore, City and Grove Views
- Private Outdoor Terraces
- Italian Terrazzo & Quartz Countertops
- Italian Cabinetry
- European Porcelain Tile Floors
- Custom Kitchen Island

- Premium Appliances Subzero Wolf
- Solid Core Interior Wood Doors
- Pre-Wired for High-Speed Internet

Body & Mind Wellness Center

- Whole-Body Fitness Zones
- Stretch, Cardio, Weights & Fitness
- Personal Trainers & Specialty Classes Available
- Wellness Lounge w/Juice Bar
- Indoor Yoga Studio
- Peloton Studio
- Men's and Women's Locker Rooms
- Signature Spa with Treatment Rooms
- Steam & Sauna

Bayshore Owners' Club

- Bayshore Club Pool w/Sundeck
- Poolside Food & Beverage Service
- Cabanas w/Towel Service
- Pool Bar & Event Lounge
- Garden-Level Lap Pool
- Billiards Room
- Library & Screen Lounge
- Little C's Learning & Adventure Lab
- Teen Game Lounge
- Business Lounge w/Meeting Rooms

Mr. C Sales Gallery
2640 S. Bayshore Drive
Coconut Grove, FL 33133

MRCGrove.com

COME HOME TO MR. C

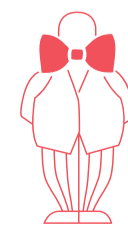

RESIDENCE
06

Exclusive Sales and Marketing by
Douglas Elliman Development Marketing

Terra

This project is being developed by CG Summer Investments, LLP, a Florida limited liability partnership ("Developer"), which has a limited right to use the trademarked names and logos of Terra and Mr. C. Any and all statements, disclosures and/or representations shall be deemed made by Developer and not by Terra and/or Mr. C, and you agree to look solely to Developer (and not to Terra, Mr. C and/or any of their affiliates) with respect to any and all matters relating to the sales and marketing and/or development of the project. ORAL REPRESENTATIONS CANNOT BE RELIED UPON AS CORRECTLY STATING THE REPRESENTATIONS OF THE DEVELOPER. FOR CORRECT REPRESENTATIONS, MAKE REFERENCE TO THIS BROCHURE AND TO THE DOCUMENTS REQUIRED BY SECTION 718.503, FLORIDA STATUTES, TO BE FURNISHED BY A DEVELOPER TO A BUYER OR LESSEE. These materials are not intended to be an offer to sell, or solicitation to buy a unit in the condominium. Such an offering shall only be made pursuant to the prospectus (offering circular) for the condominium and no statements should be relied upon unless made in the prospectus or in the applicable purchase agreement. In no event shall any solicitation, offer or sale of a unit in the condominium be made in, or to residents of, any state or country in which such activity would be unlawful.

Mr. C
RESIDENCES
COCONUT GROVE, FL

BY
IGNAZIO
AND
MAGGIO
CIPRIANI

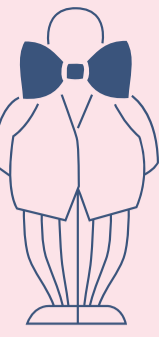

FEATURES

- 2 Bedrooms**
- 2 Bathrooms**
- Powder Room**

INDOOR AREA

964 ft²
90 m²

OUTDOOR LIVING

170 ft²
16 m²

TOTAL AREA

1134 ft²
105 m²

Exclusive Sales and Marketing by Douglas Elliman Development Marketing

Stated square footages and dimensions are measured to the exterior boundaries of the exterior walls and the centerline of interior demising walls and in fact vary from the square footage and dimensions that would be determined by using the description and definition of the "Unit" set forth in the Declaration (which generally only includes the interior airspace between the perimeter walls and excludes all interior structural components and other common elements). This method is generally used in sales materials and is provided to allow a prospective buyer to compare the Units with units in other condominium projects that utilize the same method. Measurements of rooms set forth on this floor plan are generally taken at the farthest points of each given room (as if the room were a perfect rectangle), without regard for any cutouts or variations. Accordingly, the area of the actual room will typically be smaller than the product obtained by multiplying the stated length and width. All dimensions are estimates which will vary with actual construction, and all floor plans, specifications and other development plans are subject to change and will not necessarily accurately reflect the final plans and specifications for the development.

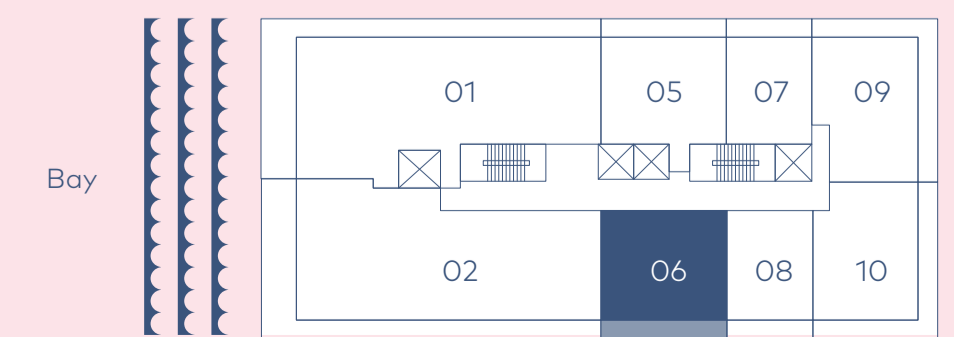
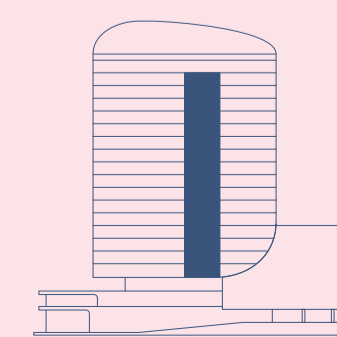



FEATURES & AMENITIES

DETAILS OF A LIFE WELL LIVED

Personalized services, including a 24-hour concierge, are complemented by a host of amenities at Mr. C Residences Coconut Grove.

Arrival Experience

- Covered Valet Drop-Off
- Reception and Concierge Desk
- Lobby Lounge
- Mail & Package Rooms
- Curated Art Pieces in Lobby
- Lush Landscaping

Dining & Retail

- Signature Café
- Specialty Gourmet Market
- Wellness Lounge and Juice Bar
- Private Bellini Bar on Pool Deck
- Poolside Food and Beverage Service
- In-Home Delivery from Café

Services

- Concierge Reception
- Butler Service
- Lifestyle and Nautical Concierge
- 24-Hour Doorman & Security
- 24-Hour Valet
- Mr. C Property Management Team
- Housekeeping Service Available

Residence Features

- Open Floor Plan Layouts
- 11-Foot Ceilings
- Floor-to-Ceiling Glass
- Bayshore, City and Grove Views
- Private Outdoor Terraces
- Italian Terrazzo & Quartz Countertops
- Italian Cabinetry
- European Porcelain Tile Floors
- Custom Kitchen Island

- Premium Appliances Subzero Wolf
- Solid Core Interior Wood Doors
- Pre-Wired for High-Speed Internet

Body & Mind Wellness Center

- Whole-Body Fitness Zones
- Stretch, Cardio, Weights & Fitness
- Personal Trainers & Specialty Classes Available
- Wellness Lounge w/Juice Bar
- Indoor Yoga Studio
- Peloton Studio
- Men's and Women's Locker Rooms
- Signature Spa with Treatment Rooms
- Steam & Sauna

Bayshore Owners' Club

- Bayshore Club Pool w/Sundeck
- Poolside Food & Beverage Service
- Cabanas w/Towel Service
- Pool Bar & Event Lounge
- Garden-Level Lap Pool
- Billiards Room
- Library & Screen Lounge
- Little C's Learning & Adventure Lab
- Teen Game Lounge
- Business Lounge w/Meeting Rooms

Mr. C Sales Gallery
2640 S. Bayshore Drive
Coconut Grove, FL 33133

MRCGrove.com

COME HOME TO MR. C

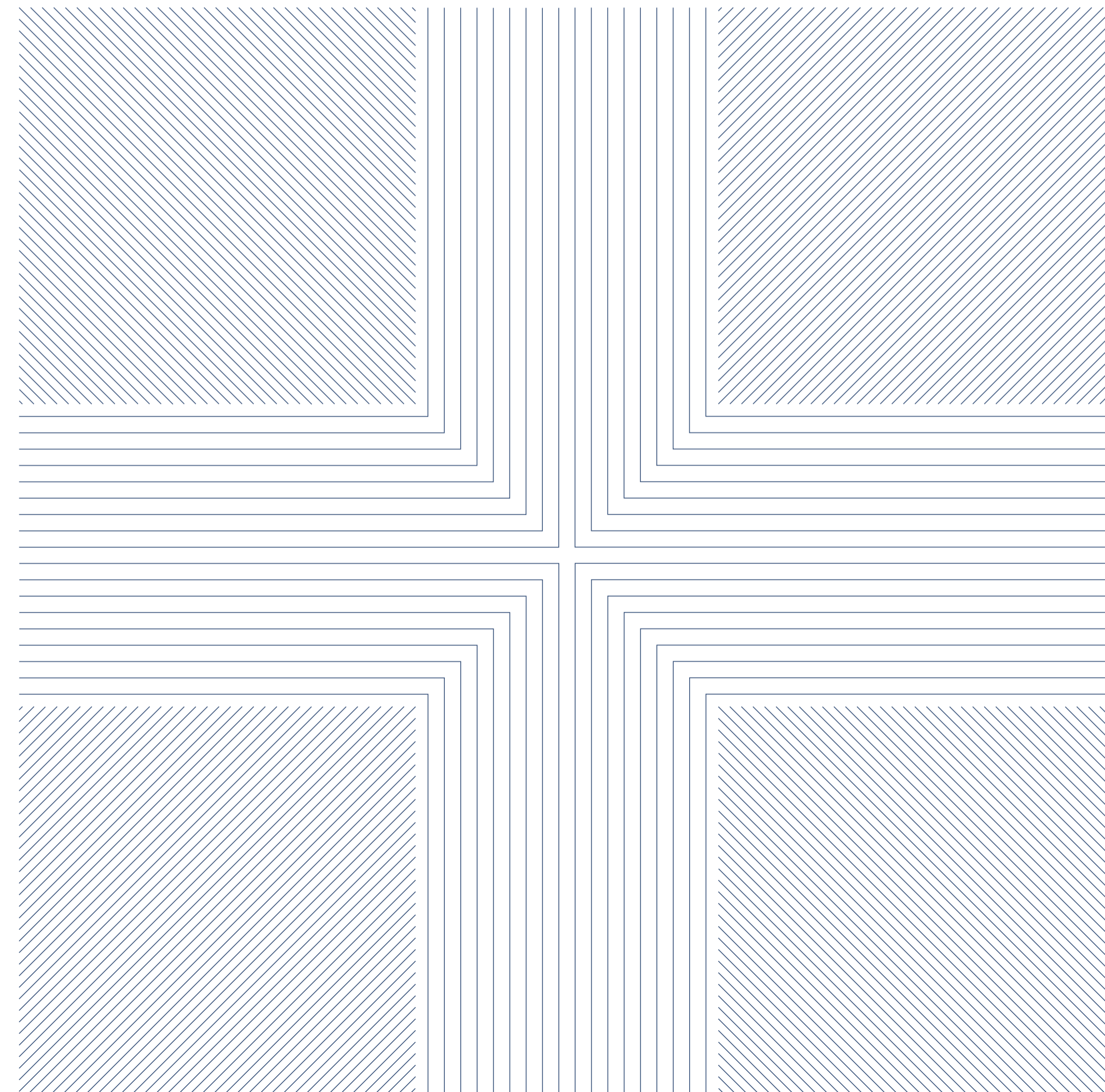

RESIDENCE
07

Exclusive Sales and Marketing by
Douglas Elliman Development Marketing

Terra

This project is being developed by CG Summer Investments, LLP, a Florida limited liability partnership ("Developer"), which has a limited right to use the trademarked names and logos of Terra and Mr. C. Any and all statements, disclosures and/or representations shall be deemed made by Developer and not by Terra and/or Mr. C, and you agree to look solely to Developer (and not to Terra, Mr. C and/or any of their affiliates) with respect to any and all matters relating to the sales and marketing and/or development of the project. ORAL REPRESENTATIONS CANNOT BE RELIED UPON AS CORRECTLY STATING THE REPRESENTATIONS OF THE DEVELOPER. FOR CORRECT REPRESENTATIONS, MAKE REFERENCE TO THIS BROCHURE AND TO THE DOCUMENTS REQUIRED BY SECTION 718.503, FLORIDA STATUTES, TO BE FURNISHED BY A DEVELOPER TO A BUYER OR LESSEE. These materials are not intended to be an offer to sell, or solicitation to buy a unit in the condominium. Such an offering shall only be made pursuant to the prospectus (offering circular) for the condominium and no statements should be relied upon unless made in the prospectus or in the applicable purchase agreement. In no event shall any solicitation, offer or sale of a unit in the condominium be made in, or to residents of, any state or country in which such activity would be unlawful.

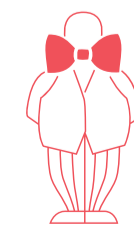

Mr. C
RESIDENCES
COCONUT GROVE, FL

BY
IGNAZIO
AND
MAGGIO
CIPRIANI

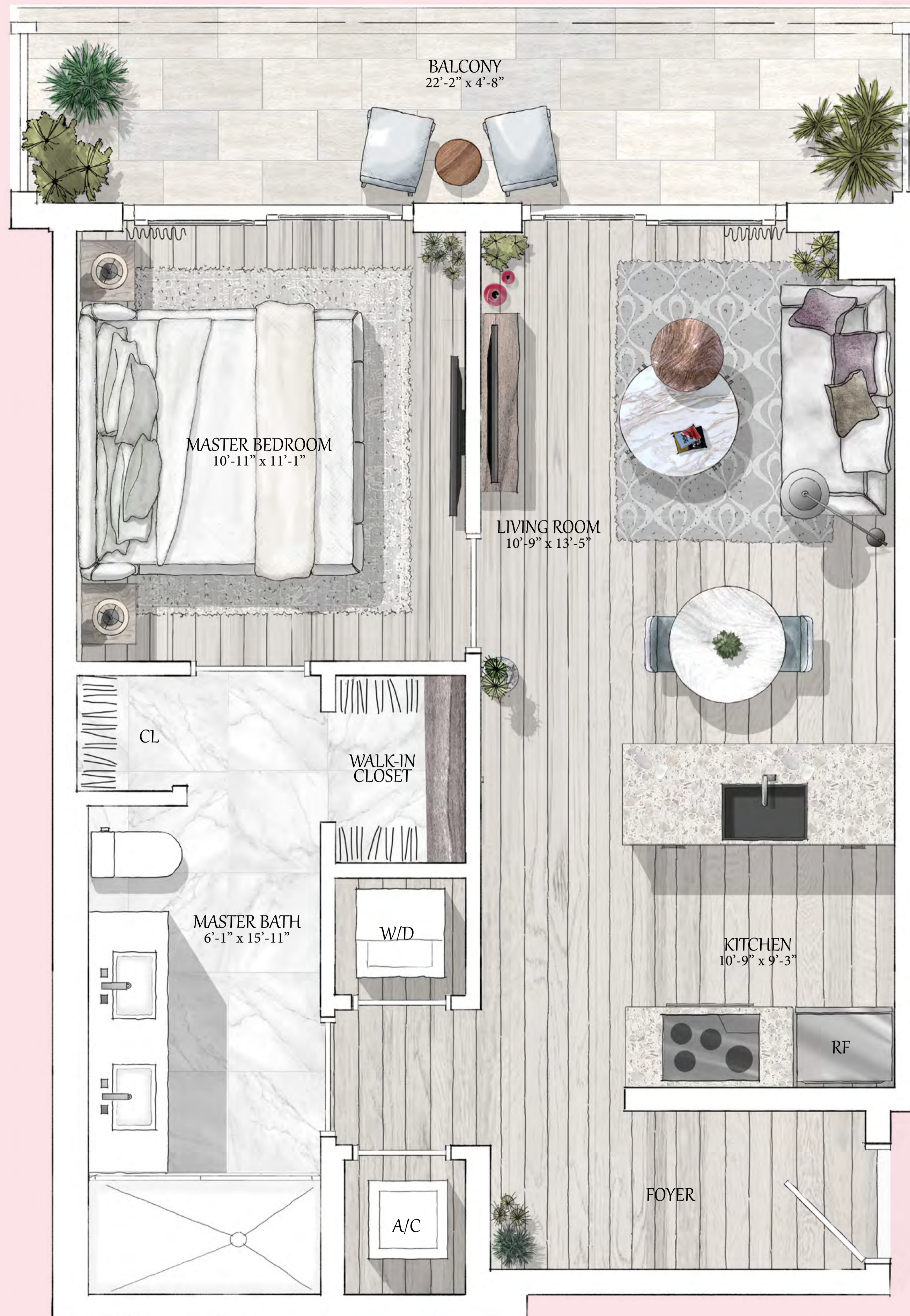
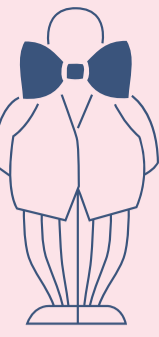

FEATURES

1 Bedrooms
1 Bathrooms

INDOOR AREA

650 ft²
60 m²

OUTDOOR LIVING

114 ft²
11 m²

TOTAL AREA

764 ft²
71 m²

Exclusive Sales and Marketing by Douglas Elliman Development Marketing

Stated square footages and dimensions are measured to the exterior boundaries of the exterior walls and the centerline of interior demising walls and in fact vary from the square footage and dimensions that would be determined by using the description and definition of the "Unit" set forth in the Declaration (which generally only includes the interior airspace between the perimeter walls and excludes all interior structural components and other common elements). This method is generally used in sales materials and is provided to allow a prospective buyer to compare the Units with units in other condominium projects that utilize the same method. Measurements of rooms set forth on this floor plan are generally taken at the farthest points of each given room (as if the room were a perfect rectangle), without regard for any cutouts or variations. Accordingly, the area of the actual room will typically be smaller than the product obtained by multiplying the stated length and width. All dimensions are estimates which will vary with actual construction, and all floor plans, specifications and other development plans are subject to change and will not necessarily accurately reflect the final plans and specifications for the development.

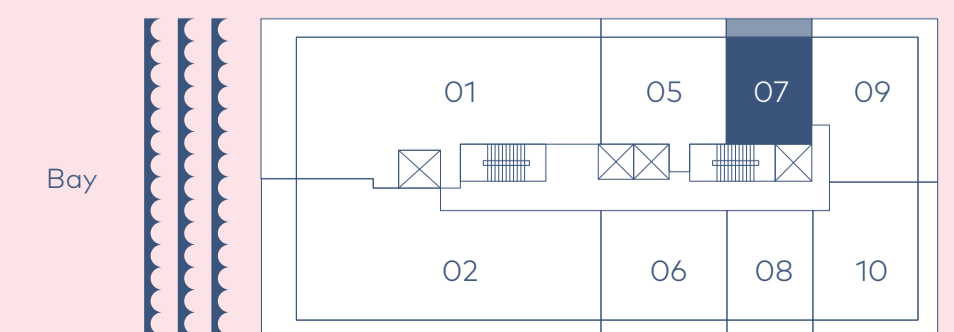
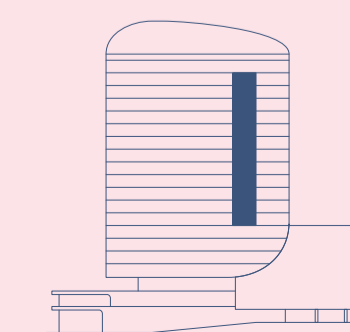



FEATURES & AMENITIES

DETAILS OF A LIFE WELL LIVED

Personalized services, including a 24-hour concierge, are complemented by a host of amenities at Mr. C Residences Coconut Grove.

Arrival Experience

- Covered Valet Drop-Off
- Reception and Concierge Desk
- Lobby Lounge
- Mail & Package Rooms
- Curated Art Pieces in Lobby
- Lush Landscaping

Dining & Retail

- Signature Café
- Specialty Gourmet Market
- Wellness Lounge and Juice Bar
- Private Bellini Bar on Pool Deck
- Poolside Food and Beverage Service
- In-Home Delivery from Café

Services

- Concierge Reception
- Butler Service
- Lifestyle and Nautical Concierge
- 24-Hour Doorman & Security
- 24-Hour Valet
- Mr. C Property Management Team
- Housekeeping Service Available

Residence Features

- Open Floor Plan Layouts
- 11-Foot Ceilings
- Floor-to-Ceiling Glass
- Bayshore, City and Grove Views
- Private Outdoor Terraces
- Italian Terrazzo & Quartz Countertops
- Italian Cabinetry
- European Porcelain Tile Floors
- Custom Kitchen Island

- Premium Appliances Subzero Wolf
- Solid Core Interior Wood Doors
- Pre-Wired for High-Speed Internet

Body & Mind Wellness Center

- Whole-Body Fitness Zones
- Stretch, Cardio, Weights & Fitness
- Personal Trainers & Specialty Classes Available
- Wellness Lounge w/Juice Bar
- Indoor Yoga Studio
- Peloton Studio
- Men's and Women's Locker Rooms
- Signature Spa with Treatment Rooms
- Steam & Sauna

Bayshore Owners' Club

- Bayshore Club Pool w/Sundeck
- Poolside Food & Beverage Service
- Cabanas w/Towel Service
- Pool Bar & Event Lounge
- Garden-Level Lap Pool
- Billiards Room
- Library & Screen Lounge
- Little C's Learning & Adventure Lab
- Teen Game Lounge
- Business Lounge w/Meeting Rooms

Mr. C Sales Gallery
2640 S. Bayshore Drive
Coconut Grove, FL 33133

MRCGrove.com

COME HOME TO MR. C

RESIDENCE
08

Exclusive Sales and Marketing by
Douglas Elliman Development Marketing



This project is being developed by CG Summer Investments, LLP, a Florida limited liability partnership ("Developer"), which has a limited right to use the trademarked names and logos of Terra and Mr. C. Any and all statements, disclosures and/or representations shall be deemed made by Developer and not by Terra and/or Mr. C, and you agree to look solely to Developer (and not to Terra, Mr. C and/or any of their affiliates) with respect to any and all matters relating to the sales and marketing and/or development of the project. ORAL REPRESENTATIONS CANNOT BE RELIED UPON AS CORRECTLY STATING THE REPRESENTATIONS OF THE DEVELOPER. FOR CORRECT REPRESENTATIONS, MAKE REFERENCE TO THIS BROCHURE AND TO THE DOCUMENTS REQUIRED BY SECTION 718.503, FLORIDA STATUTES, TO BE FURNISHED BY A DEVELOPER TO A BUYER OR LESSEE. These materials are not intended to be an offer to sell, or solicitation to buy a unit in the condominium. Such an offering shall only be made pursuant to the prospectus (offering circular) for the condominium and no statements should be relied upon unless made in the prospectus or in the applicable purchase agreement. In no event shall any solicitation, offer or sale of a unit in the condominium be made in, or to residents of, any state or country in which such activity would be unlawful.

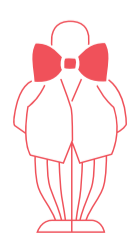

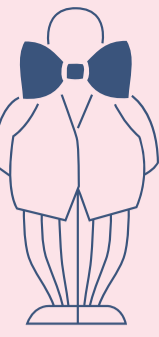

FEATURES

1 Bedrooms
1 Bathrooms

INDOOR AREA

651 ft²
60 m²

OUTDOOR LIVING

112 ft²
10 m²

TOTAL AREA

763 ft²
71 m²

Exclusive Sales and Marketing by Douglas Elliman Development Marketing

Stated square footages and dimensions are measured to the exterior boundaries of the exterior walls and the centerline of interior demising walls and in fact vary from the square footage and dimensions that would be determined by using the description and definition of the "Unit" set forth in the Declaration (which generally only includes the interior airspace between the perimeter walls and excludes all interior structural components and other common elements). This method is generally used in sales materials and is provided to allow a prospective buyer to compare the Units with units in other condominium projects that utilize the same method. Measurements of rooms set forth on this floor plan are generally taken at the farthest points of each given room (as if the room were a perfect rectangle), without regard for any cutouts or variations. Accordingly, the area of the actual room will typically be smaller than the product obtained by multiplying the stated length and width. All dimensions are estimates which will vary with actual construction, and all floor plans, specifications and other development plans are subject to change and will not necessarily accurately reflect the final plans and specifications for the development.

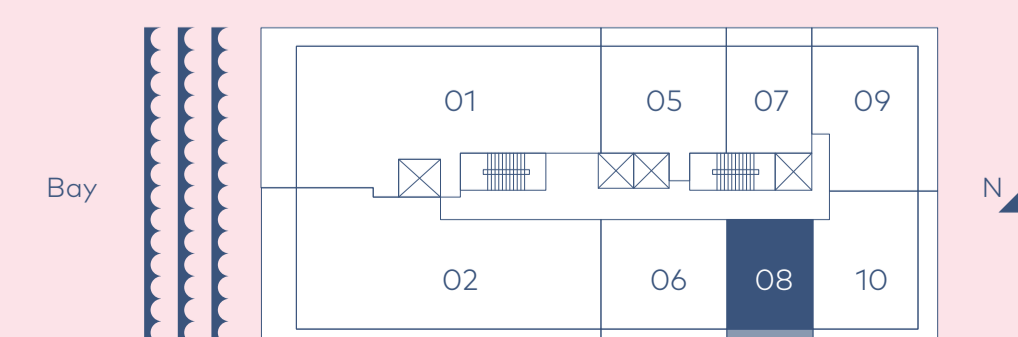
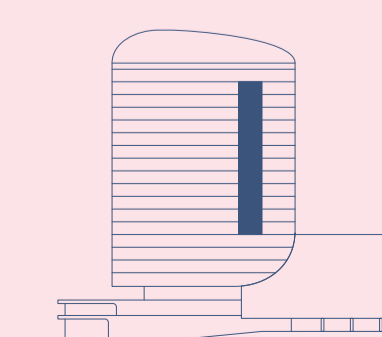



FEATURES & AMENITIES

DETAILS OF A LIFE WELL LIVED

Personalized services, including a 24-hour concierge, are complemented by a host of amenities at Mr. C Residences Coconut Grove.

Arrival Experience

- Covered Valet Drop-Off
- Reception and Concierge Desk
- Lobby Lounge
- Mail & Package Rooms
- Curated Art Pieces in Lobby
- Lush Landscaping

Dining & Retail

- Signature Café
- Specialty Gourmet Market
- Wellness Lounge and Juice Bar
- Private Bellini Bar on Pool Deck
- Poolside Food and Beverage Service
- In-Home Delivery from Café

Services

- Concierge Reception
- Butler Service
- Lifestyle and Nautical Concierge
- 24-Hour Doorman & Security
- 24-Hour Valet
- Mr. C Property Management Team
- Housekeeping Service Available

Residence Features

- Open Floor Plan Layouts
- 11-Foot Ceilings
- Floor-to-Ceiling Glass
- Bayshore, City and Grove Views
- Private Outdoor Terraces
- Italian Terrazzo & Quartz Countertops
- Italian Cabinetry
- European Porcelain Tile Floors
- Custom Kitchen Island

- Premium Appliances Subzero Wolf
- Solid Core Interior Wood Doors
- Pre-Wired for High-Speed Internet

Body & Mind Wellness Center

- Whole-Body Fitness Zones
- Stretch, Cardio, Weights & Fitness
- Personal Trainers & Specialty Classes Available
- Wellness Lounge w/Juice Bar
- Indoor Yoga Studio
- Peloton Studio
- Men's and Women's Locker Rooms
- Signature Spa with Treatment Rooms
- Steam & Sauna

Bayshore Owners' Club

- Bayshore Club Pool w/Sundeck
- Poolside Food & Beverage Service
- Cabanas w/Towel Service
- Pool Bar & Event Lounge
- Garden-Level Lap Pool
- Billiards Room
- Library & Screen Lounge
- Little C's Learning & Adventure Lab
- Teen Game Lounge
- Business Lounge w/Meeting Rooms

Mr. C Sales Gallery
2640 S. Bayshore Drive
Coconut Grove, FL 33133

MRCGrove.com

COME HOME TO MR. C

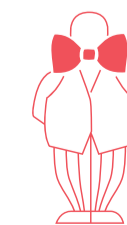

RESIDENCE
09

Exclusive Sales and Marketing by
Douglas Elliman Development Marketing

 Terra

This project is being developed by CG Summer Investments, LLP, a Florida limited liability partnership ("Developer"), which has a limited right to use the trademarked names and logos of Terra and Mr. C. Any and all statements, disclosures and/or representations shall be deemed made by Developer and not by Terra and/or Mr. C, and you agree to look solely to Developer (and not to Terra, Mr. C and/or any of their affiliates) with respect to any and all matters relating to the sales and marketing and/or development of the project. ORAL REPRESENTATIONS CANNOT BE RELIED UPON AS CORRECTLY STATING THE REPRESENTATIONS OF THE DEVELOPER. FOR CORRECT REPRESENTATIONS, MAKE REFERENCE TO THIS BROCHURE AND TO THE DOCUMENTS REQUIRED BY SECTION 718.503, FLORIDA STATUTES, TO BE FURNISHED BY A DEVELOPER TO A BUYER OR LESSEE. These materials are not intended to be an offer to sell, or solicitation to buy a unit in the condominium. Such an offering shall only be made pursuant to the prospectus (offering circular) for the condominium and no statements should be relied upon unless made in the prospectus or in the applicable purchase agreement. In no event shall any solicitation, offer or sale of a unit in the condominium be made in, or to residents of, any state or country in which such activity would be unlawful.

Mr. C
RESIDENCES
COCONUT GROVE, FL

BY
IGNAZIO
AND
MAGGIO
CIPRIANI

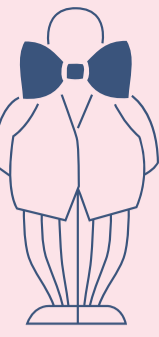

FEATURES
2 Bedrooms
2 Bathrooms
Powder Room

INDOOR AREA
995 ft²
92 m²

OUTDOOR LIVING
360 ft²
33 m²

TOTAL AREA
1355 ft²
126 m²

Exclusive Sales and Marketing by Douglas Elliman Development Marketing

Stated square footages and dimensions are measured to the exterior boundaries of the exterior walls and the centerline of interior demising walls and in fact vary from the square footage and dimensions that would be determined by using the description and definition of the "Unit" set forth in the Declaration (which generally only includes the interior airspace between the perimeter walls and excludes all interior structural components and other common elements). This method is generally used in sales materials and is provided to allow a prospective buyer to compare the Units with units in other condominium projects that utilize the same method. Measurements of rooms set forth on this floor plan are generally taken at the farthest points of each given room (as if the room were a perfect rectangle), without regard for any cutouts or variations. Accordingly, the area of the actual room will typically be smaller than the product obtained by multiplying the stated length and width. All dimensions are estimates which will vary with actual construction, and all floor plans, specifications and other development plans are subject to change and will not necessarily accurately reflect the final plans and specifications for the development.

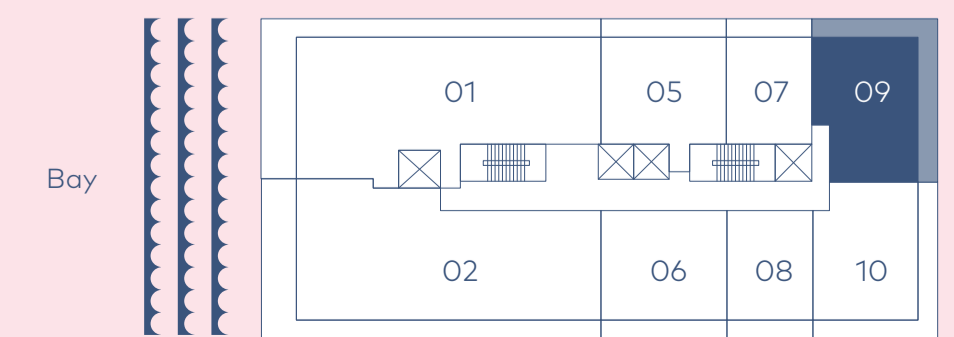
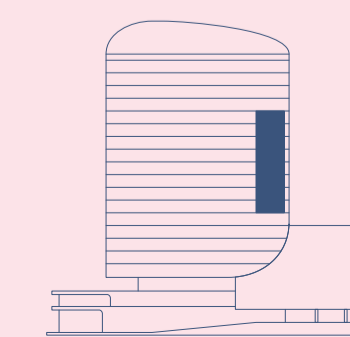



FEATURES & AMENITIES

DETAILS OF A LIFE WELL LIVED

Personalized services, including a 24-hour concierge, are complemented by a host of amenities at Mr. C Residences Coconut Grove.

Arrival Experience

- Covered Valet Drop-Off
- Reception and Concierge Desk
- Lobby Lounge
- Mail & Package Rooms
- Curated Art Pieces in Lobby
- Lush Landscaping

Dining & Retail

- Signature Café
- Specialty Gourmet Market
- Wellness Lounge and Juice Bar
- Private Bellini Bar on Pool Deck
- Poolside Food and Beverage Service
- In-Home Delivery from Café

Services

- Concierge Reception
- Butler Service
- Lifestyle and Nautical Concierge
- 24-Hour Doorman & Security
- 24-Hour Valet
- Mr. C Property Management Team
- Housekeeping Service Available

Residence Features

- Open Floor Plan Layouts
- 11-Foot Ceilings
- Floor-to-Ceiling Glass
- Bayshore, City and Grove Views
- Private Outdoor Terraces
- Italian Terrazzo & Quartz Countertops
- Italian Cabinetry
- European Porcelain Tile Floors
- Custom Kitchen Island

- Premium Appliances Subzero Wolf
- Solid Core Interior Wood Doors
- Pre-Wired for High-Speed Internet

Body & Mind Wellness Center

- Whole-Body Fitness Zones
- Stretch, Cardio, Weights & Fitness
- Personal Trainers & Specialty Classes Available
- Wellness Lounge w/Juice Bar
- Indoor Yoga Studio
- Peloton Studio
- Men's and Women's Locker Rooms
- Signature Spa with Treatment Rooms
- Steam & Sauna

Bayshore Owners' Club

- Bayshore Club Pool w/Sundeck
- Poolside Food & Beverage Service
- Cabanas w/Towel Service
- Pool Bar & Event Lounge
- Garden-Level Lap Pool
- Billiards Room
- Library & Screen Lounge
- Little C's Learning & Adventure Lab
- Teen Game Lounge
- Business Lounge w/Meeting Rooms

Mr. C Sales Gallery
2640 S. Bayshore Drive
Coconut Grove, FL 33133

MRCGrove.com

COME HOME TO MR. C

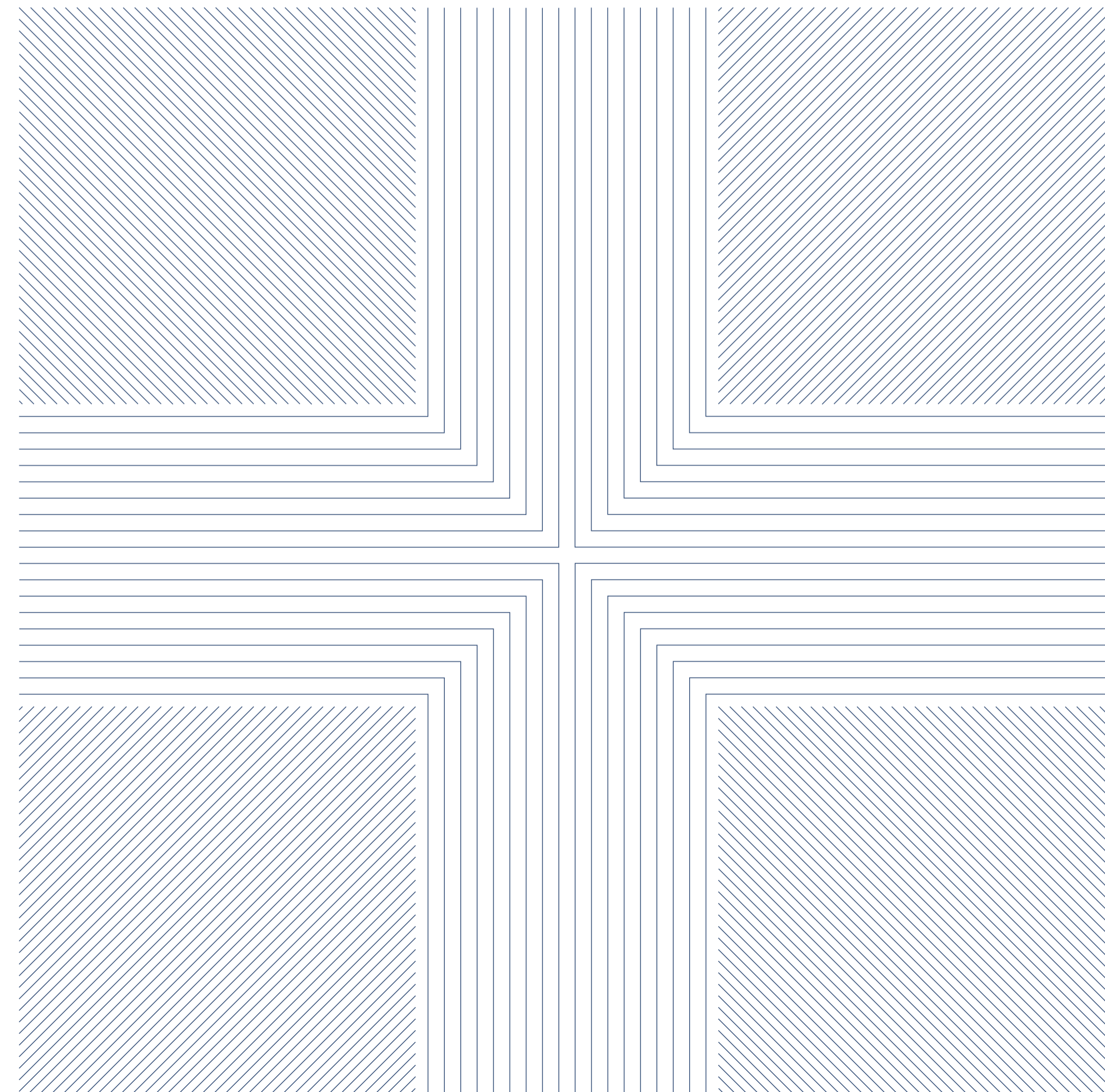

RESIDENCE
10

Exclusive Sales and Marketing by
Douglas Elliman Development Marketing

Terra

This project is being developed by CG Summer Investments, LLP, a Florida limited liability partnership ("Developer"), which has a limited right to use the trademarked names and logos of Terra and Mr. C. Any and all statements, disclosures and/or representations shall be deemed made by Developer and not by Terra and/or Mr. C, and you agree to look solely to Developer (and not to Terra, Mr. C and/or any of their affiliates) with respect to any and all matters relating to the sales and marketing and/or development of the project. ORAL REPRESENTATIONS CANNOT BE RELIED UPON AS CORRECTLY STATING THE REPRESENTATIONS OF THE DEVELOPER. FOR CORRECT REPRESENTATIONS, MAKE REFERENCE TO THIS BROCHURE AND TO THE DOCUMENTS REQUIRED BY SECTION 718.503, FLORIDA STATUTES, TO BE FURNISHED BY A DEVELOPER TO A BUYER OR LESSEE. These materials are not intended to be an offer to sell, or solicitation to buy a unit in the condominium. Such an offering shall only be made pursuant to the prospectus (offering circular) for the condominium and no statements should be relied upon unless made in the prospectus or in the applicable purchase agreement. In no event shall any solicitation, offer or sale of a unit in the condominium be made in, or to residents of, any state or country in which such activity would be unlawful.

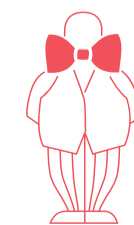

Mr. C
RESIDENCES
COCONUT GROVE, FL

BY
IGNAZIO
AND
MAGGIO
CIPRIANI

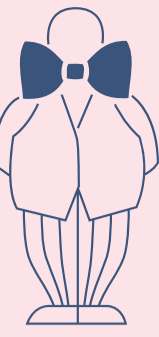

FEATURES

2 Bedrooms
2 Bathrooms

INDOOR AREA

1023 ft²
95 m²

OUTDOOR LIVING

360 ft²
33 m²

TOTAL AREA

1383 ft²
128 m²

Exclusive Sales and Marketing by Douglas Elliman Development Marketing

Stated square footages and dimensions are measured to the exterior boundaries of the exterior walls and the centerline of interior demising walls and in fact vary from the square footage and dimensions that would be determined by using the description and definition of the "Unit" set forth in the Declaration (which generally only includes the interior airspace between the perimeter walls and excludes all interior structural components and other common elements). This method is generally used in sales materials and is provided to allow a prospective buyer to compare the Units with units in other condominium projects that utilize the same method. Measurements of rooms set forth on this floor plan are generally taken at the farthest points of each given room (as if the room were a perfect rectangle), without regard for any cutouts or variations. Accordingly, the area of the actual room will typically be smaller than the product obtained by multiplying the stated length and width. All dimensions are estimates which will vary with actual construction, and all floor plans, specifications and other development plans are subject to change and will not necessarily accurately reflect the final plans and specifications for the development.

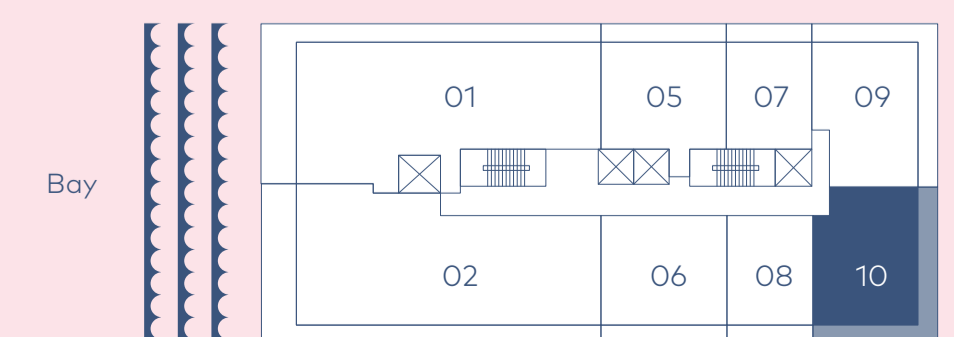
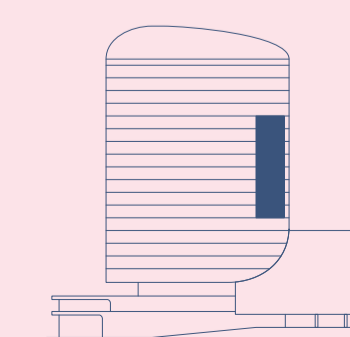



FEATURES & AMENITIES

DETAILS OF A LIFE WELL LIVED

Personalized services, including a 24-hour concierge, are complemented by a host of amenities at Mr. C Residences Coconut Grove.

Arrival Experience

- Covered Valet Drop-Off
- Reception and Concierge Desk
- Lobby Lounge
- Mail & Package Rooms
- Curated Art Pieces in Lobby
- Lush Landscaping

Dining & Retail

- Signature Café
- Specialty Gourmet Market
- Wellness Lounge and Juice Bar
- Private Bellini Bar on Pool Deck
- Poolside Food and Beverage Service
- In-Home Delivery from Café

Services

- Concierge Reception
- Butler Service
- Lifestyle and Nautical Concierge
- 24-Hour Doorman & Security
- 24-Hour Valet
- Mr. C Property Management Team
- Housekeeping Service Available

Residence Features

- Open Floor Plan Layouts
- 11-Foot Ceilings
- Floor-to-Ceiling Glass
- Bayshore, City and Grove Views
- Private Outdoor Terraces
- Italian Terrazzo & Quartz Countertops
- Italian Cabinetry
- European Porcelain Tile Floors
- Custom Kitchen Island

- Premium Appliances Subzero Wolf
- Solid Core Interior Wood Doors
- Pre-Wired for High-Speed Internet

Body & Mind Wellness Center

- Whole-Body Fitness Zones
- Stretch, Cardio, Weights & Fitness
- Personal Trainers & Specialty Classes Available
- Wellness Lounge w/Juice Bar
- Indoor Yoga Studio
- Peloton Studio
- Men's and Women's Locker Rooms
- Signature Spa with Treatment Rooms
- Steam & Sauna

Bayshore Owners' Club

- Bayshore Club Pool w/Sundeck
- Poolside Food & Beverage Service
- Cabanas w/Towel Service
- Pool Bar & Event Lounge
- Garden-Level Lap Pool
- Billiards Room
- Library & Screen Lounge
- Little C's Learning & Adventure Lab
- Teen Game Lounge
- Business Lounge w/Meeting Rooms

Mr. C Sales Gallery
2640 S. Bayshore Drive
Coconut Grove, FL 33133

MRCGrove.com

COME HOME TO MR. C

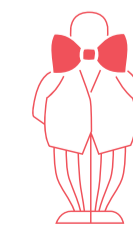

Exclusive Sales and Marketing by
Douglas Elliman Development Marketing

Terra

This project is being developed by CG Summer Investments, LLP, a Florida limited liability partnership ("Developer"), which has a limited right to use the trademarked names and logos of Terra and Mr. C. Any and all statements, disclosures and/or representations shall be deemed made by Developer and not by Terra and/or Mr. C, and you agree to look solely to Developer (and not to Terra, Mr. C and/or any of their affiliates) with respect to any and all matters relating to the sales and marketing and/or development of the project. ORAL REPRESENTATIONS CANNOT BE RELIED UPON AS CORRECTLY STATING THE REPRESENTATIONS OF THE DEVELOPER. FOR CORRECT REPRESENTATIONS, MAKE REFERENCE TO THIS BROCHURE AND TO THE DOCUMENTS REQUIRED BY SECTION 718.503, FLORIDA STATUTES, TO BE FURNISHED BY A DEVELOPER TO A BUYER OR LESSEE. These materials are not intended to be an offer to sell, or solicitation to buy a unit in the condominium. Such an offering shall only be made pursuant to the prospectus (offering circular) for the condominium and no statements should be relied upon unless made in the prospectus or in the applicable purchase agreement. In no event shall any solicitation, offer or sale of a unit in the condominium be made in, or to residents of, any state or country in which such activity would be unlawful.

RESIDENCE
11

Mr. C
RESIDENCES
COCONUT GROVE, FL

BY
IGNAZIO
AND
MAGGIO
CIPRIANI

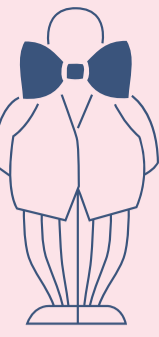

FEATURES

- 3 Bedrooms
- 3 Bathrooms
- Powder Room

INDOOR AREA
1746 ft²
162 m²

OUTDOOR LIVING
475 ft²
44 m²

TOTAL AREA
2221 ft²
206 m²

Exclusive Sales and Marketing by Douglas Elliman Development Marketing

Stated square footages and dimensions are measured to the exterior boundaries of the exterior walls and the centerline of interior demising walls and in fact vary from the square footage and dimensions that would be determined by using the description and definition of the "Unit" set forth in the Declaration (which generally only includes the interior airspace between the perimeter walls and excludes all interior structural components and other common elements). This method is generally used in sales materials and is provided to allow a prospective buyer to compare the Units with units in other condominium projects that utilize the same method. Measurements of rooms set forth on this floor plan are generally taken at the farthest points of each given room (as if the room were a perfect rectangle), without regard for any cutouts or variations. Accordingly, the area of the actual room will typically be smaller than the product obtained by multiplying the stated length and width. All dimensions are estimates which will vary with actual construction, and all floor plans, specifications and other development plans are subject to change and will not necessarily accurately reflect the final plans and specifications for the development.

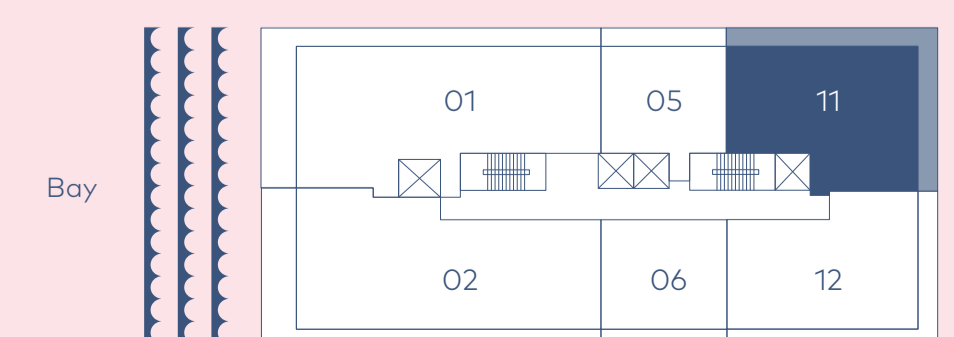
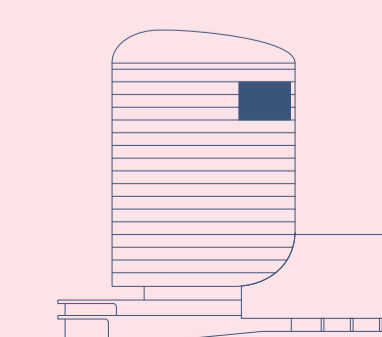



FEATURES & AMENITIES

DETAILS OF A LIFE WELL LIVED

Personalized services, including a 24-hour concierge, are complemented by a host of amenities at Mr. C Residences Coconut Grove.

Arrival Experience

- Covered Valet Drop-Off
- Reception and Concierge Desk
- Lobby Lounge
- Mail & Package Rooms
- Curated Art Pieces in Lobby
- Lush Landscaping

Dining & Retail

- Signature Café
- Specialty Gourmet Market
- Wellness Lounge and Juice Bar
- Private Bellini Bar on Pool Deck
- Poolside Food and Beverage Service
- In-Home Delivery from Café

Services

- Concierge Reception
- Butler Service
- Lifestyle and Nautical Concierge
- 24-Hour Doorman & Security
- 24-Hour Valet
- Mr. C Property Management Team
- Housekeeping Service Available

Residence Features

- Open Floor Plan Layouts
- 11-Foot Ceilings
- Floor-to-Ceiling Glass
- Bayshore, City and Grove Views
- Private Outdoor Terraces
- Italian Terrazzo & Quartz Countertops
- Italian Cabinetry
- European Porcelain Tile Floors
- Custom Kitchen Island

- Premium Appliances Subzero Wolf
- Solid Core Interior Wood Doors
- Pre-Wired for High-Speed Internet

Body & Mind Wellness Center

- Whole-Body Fitness Zones
- Stretch, Cardio, Weights & Fitness
- Personal Trainers & Specialty Classes Available
- Wellness Lounge w/Juice Bar
- Indoor Yoga Studio
- Peloton Studio
- Men's and Women's Locker Rooms
- Signature Spa with Treatment Rooms
- Steam & Sauna

Bayshore Owners' Club

- Bayshore Club Pool w/Sundeck
- Poolside Food & Beverage Service
- Cabanas w/Towel Service
- Pool Bar & Event Lounge
- Garden-Level Lap Pool
- Billiards Room
- Library & Screen Lounge
- Little C's Learning & Adventure Lab
- Teen Game Lounge
- Business Lounge w/Meeting Rooms

Mr. C Sales Gallery
2640 S. Bayshore Drive
Coconut Grove, FL 33133

MRCGrove.com

COME HOME TO MR. C

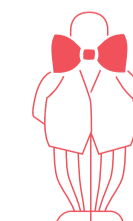

Exclusive Sales and Marketing by
Douglas Elliman Development Marketing

Terra

This project is being developed by CG Summer Investments, LLP, a Florida limited liability partnership ("Developer"), which has a limited right to use the trademarked names and logos of Terra and Mr. C. Any and all statements, disclosures and/or representations shall be deemed made by Developer and not by Terra and/or Mr. C, and you agree to look solely to Developer (and not to Terra, Mr. C and/or any of their affiliates) with respect to any and all matters relating to the sales and marketing and/or development of the project. ORAL REPRESENTATIONS CANNOT BE RELIED UPON AS CORRECTLY STATING THE REPRESENTATIONS OF THE DEVELOPER. FOR CORRECT REPRESENTATIONS, MAKE REFERENCE TO THIS BROCHURE AND TO THE DOCUMENTS REQUIRED BY SECTION 718.503, FLORIDA STATUTES, TO BE FURNISHED BY A DEVELOPER TO A BUYER OR LESSEE. These materials are not intended to be an offer to sell, or solicitation to buy a unit in the condominium. Such an offering shall only be made pursuant to the prospectus (offering circular) for the condominium and no statements should be relied upon unless made in the prospectus or in the applicable purchase agreement. In no event shall any solicitation, offer or sale of a unit in the condominium be made in, or to residents of, any state or country in which such activity would be unlawful.

RESIDENCE
12

Mr. C
RESIDENCES
COCONUT GROVE, FL

BY
IGNAZIO
AND
MAGGIO
CIPRIANI

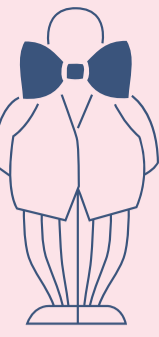

FEATURES

- 3 Bedrooms**
- 3 Bathrooms**
- Powder Room**

INDOOR AREA
1662 ft²
154 m²

OUTDOOR LIVING
470 ft²
44 m²

TOTAL AREA
2132 ft²
198 m²

Exclusive Sales and Marketing by Douglas Elliman Development Marketing

Stated square footages and dimensions are measured to the exterior boundaries of the exterior walls and the centerline of interior demising walls and in fact vary from the square footage and dimensions that would be determined by using the description and definition of the "Unit" set forth in the Declaration (which generally only includes the interior airspace between the perimeter walls and excludes all interior structural components and other common elements). This method is generally used in sales materials and is provided to allow a prospective buyer to compare the Units with units in other condominium projects that utilize the same method. Measurements of rooms set forth on this floor plan are generally taken at the farthest points of each given room (as if the room were a perfect rectangle), without regard for any cutouts or variations. Accordingly, the area of the actual room will typically be smaller than the product obtained by multiplying the stated length and width. All dimensions are estimates which will vary with actual construction, and all floor plans, specifications and other development plans are subject to change and will not necessarily accurately reflect the final plans and specifications for the development.

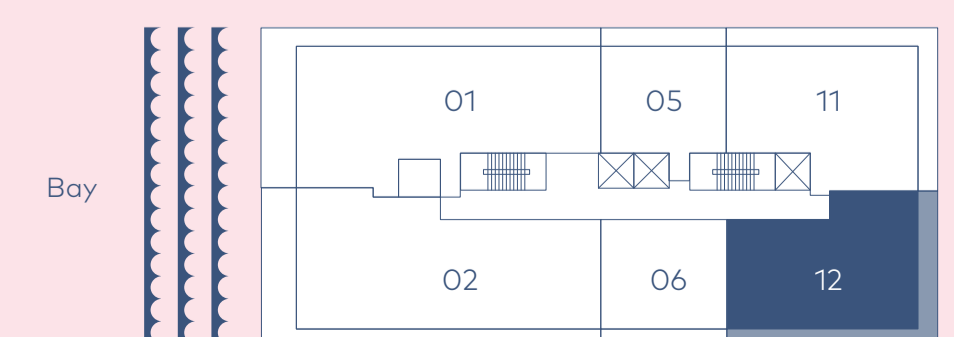
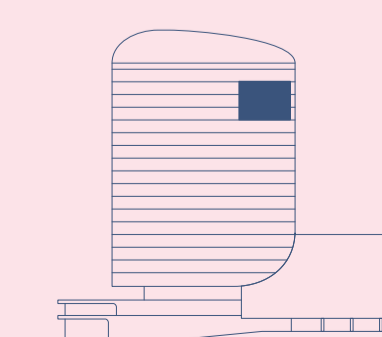



FEATURES & AMENITIES

DETAILS OF A LIFE WELL LIVED

Personalized services, including a 24-hour concierge, are complemented by a host of amenities at Mr. C Residences Coconut Grove.

Arrival Experience

- Covered Valet Drop-Off
- Reception and Concierge Desk
- Lobby Lounge
- Mail & Package Rooms
- Curated Art Pieces in Lobby
- Lush Landscaping

Dining & Retail

- Signature Café
- Specialty Gourmet Market
- Wellness Lounge and Juice Bar
- Private Bellini Bar on Pool Deck
- Poolside Food and Beverage Service
- In-Home Delivery from Café

Services

- Concierge Reception
- Butler Service
- Lifestyle and Nautical Concierge
- 24-Hour Doorman & Security
- 24-Hour Valet
- Mr. C Property Management Team
- Housekeeping Service Available

Residence Features

- Open Floor Plan Layouts
- 11-Foot Ceilings
- Floor-to-Ceiling Glass
- Bayshore, City and Grove Views
- Private Outdoor Terraces
- Italian Terrazzo & Quartz Countertops
- Italian Cabinetry
- European Porcelain Tile Floors
- Custom Kitchen Island

- Premium Appliances Subzero Wolf
- Solid Core Interior Wood Doors
- Pre-Wired for High-Speed Internet

Body & Mind Wellness Center

- Whole-Body Fitness Zones
- Stretch, Cardio, Weights & Fitness
- Personal Trainers & Specialty Classes Available
- Wellness Lounge w/Juice Bar
- Indoor Yoga Studio
- Peloton Studio
- Men's and Women's Locker Rooms
- Signature Spa with Treatment Rooms
- Steam & Sauna

Bayshore Owners' Club

- Bayshore Club Pool w/Sundeck
- Poolside Food & Beverage Service
- Cabanas w/Towel Service
- Pool Bar & Event Lounge
- Garden-Level Lap Pool
- Billiards Room
- Library & Screen Lounge
- Little C's Learning & Adventure Lab
- Teen Game Lounge
- Business Lounge w/Meeting Rooms

Mr. C Sales Gallery
2640 S. Bayshore Drive
Coconut Grove, FL 33133

MRCGrove.com

COME HOME TO MR. C

RESIDENCE
10 LANAI

Exclusive Sales and Marketing by
Douglas Elliman Development Marketing

Terra

This project is being developed by CG Summer Investments, LLP, a Florida limited liability partnership ("Developer"), which has a limited right to use the trademarked names and logos of Terra and Mr. C. Any and all statements, disclosures and/or representations shall be deemed made by Developer and not by Terra and/or Mr. C, and you agree to look solely to Developer (and not to Terra, Mr. C and/or any of their affiliates) with respect to any and all matters relating to the sales and marketing and/or development of the project. ORAL REPRESENTATIONS CANNOT BE RELIED UPON AS CORRECTLY STATING THE REPRESENTATIONS OF THE DEVELOPER. FOR CORRECT REPRESENTATIONS, MAKE REFERENCE TO THIS BROCHURE AND TO THE DOCUMENTS REQUIRED BY SECTION 718.503, FLORIDA STATUTES, TO BE FURNISHED BY A DEVELOPER TO A BUYER OR LESSEE. These materials are not intended to be an offer to sell, or solicitation to buy a unit in the condominium. Such an offering shall only be made pursuant to the prospectus (offering circular) for the condominium and no statements should be relied upon unless made in the prospectus or in the applicable purchase agreement. In no event shall any solicitation, offer or sale of a unit in the condominium be made in, or to residents of, any state or country in which such activity would be unlawful.

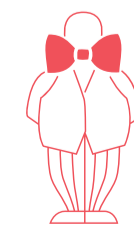

Mr. C
RESIDENCES
COCONUT GROVE, FL

BY
IGNAZIO
AND
MAGGIO
CIPRIANI

RESIDENCE

10 LANAI

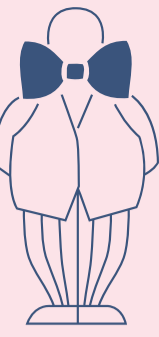

FEATURES

1 Bedrooms
1 Bathrooms

INDOOR AREA

815 ft²
76 m²

OUTDOOR LIVING

460 ft²
43 m²

TOTAL AREA

1275 ft²
118 m²

Exclusive Sales and Marketing by Douglas Elliman Development Marketing

Stated square footages and dimensions are measured to the exterior boundaries of the exterior walls and the centerline of interior demising walls and in fact vary from the square footage and dimensions that would be determined by using the description and definition of the "Unit" set forth in the Declaration (which generally only includes the interior airspace between the perimeter walls and excludes all interior structural components and other common elements). This method is generally used in sales materials and is provided to allow a prospective buyer to compare the Units with units in other condominium projects that utilize the same method. Measurements of rooms set forth on this floor plan are generally taken at the farthest points of each given room (as if the room were a perfect rectangle), without regard for any cutouts or variations. Accordingly, the area of the actual room will typically be smaller than the product obtained by multiplying the stated length and width. All dimensions are estimates which will vary with actual construction, and all floor plans, specifications and other development plans are subject to change and will not necessarily accurately reflect the final plans and specifications for the development.

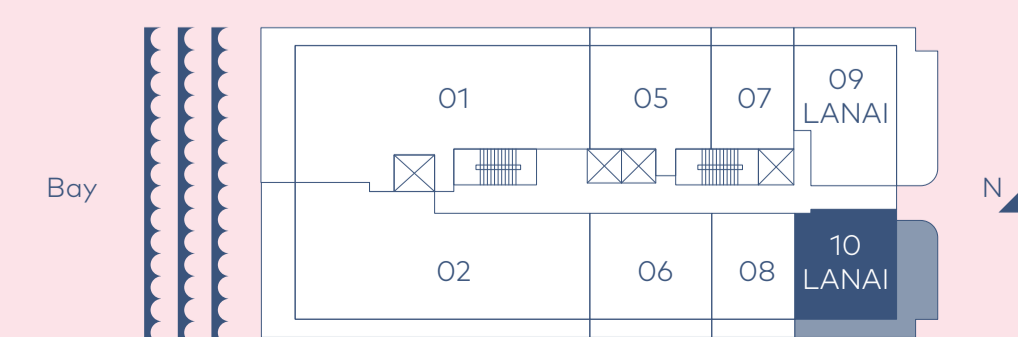
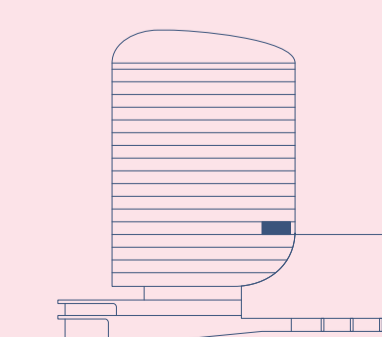



FEATURES & AMENITIES

DETAILS OF A LIFE WELL LIVED

Personalized services, including a 24-hour concierge, are complemented by a host of amenities at Mr. C Residences Coconut Grove.

Arrival Experience

- Covered Valet Drop-Off
- Reception and Concierge Desk
- Lobby Lounge
- Mail & Package Rooms
- Curated Art Pieces in Lobby
- Lush Landscaping

Dining & Retail

- Signature Café
- Specialty Gourmet Market
- Wellness Lounge and Juice Bar
- Private Bellini Bar on Pool Deck
- Poolside Food and Beverage Service
- In-Home Delivery from Café

Services

- Concierge Reception
- Butler Service
- Lifestyle and Nautical Concierge
- 24-Hour Doorman & Security
- 24-Hour Valet
- Mr. C Property Management Team
- Housekeeping Service Available

Residence Features

- Open Floor Plan Layouts
- 11-Foot Ceilings
- Floor-to-Ceiling Glass
- Bayshore, City and Grove Views
- Private Outdoor Terraces
- Italian Terrazzo & Quartz Countertops
- Italian Cabinetry
- European Porcelain Tile Floors
- Custom Kitchen Island

- Premium Appliances Subzero Wolf
- Solid Core Interior Wood Doors
- Pre-Wired for High-Speed Internet

Body & Mind Wellness Center

- Whole-Body Fitness Zones
- Stretch, Cardio, Weights & Fitness
- Personal Trainers & Specialty Classes Available
- Wellness Lounge w/Juice Bar
- Indoor Yoga Studio
- Peloton Studio
- Men's and Women's Locker Rooms
- Signature Spa with Treatment Rooms
- Steam & Sauna

Bayshore Owners' Club

- Bayshore Club Pool w/Sundeck
- Poolside Food & Beverage Service
- Cabanas w/Towel Service
- Pool Bar & Event Lounge
- Garden-Level Lap Pool
- Billiards Room
- Library & Screen Lounge
- Little C's Learning & Adventure Lab
- Teen Game Lounge
- Business Lounge w/Meeting Rooms

Mr. C Sales Gallery
2640 S. Bayshore Drive
Coconut Grove, FL 33133

MRCGrove.com

COME HOME TO MR. C

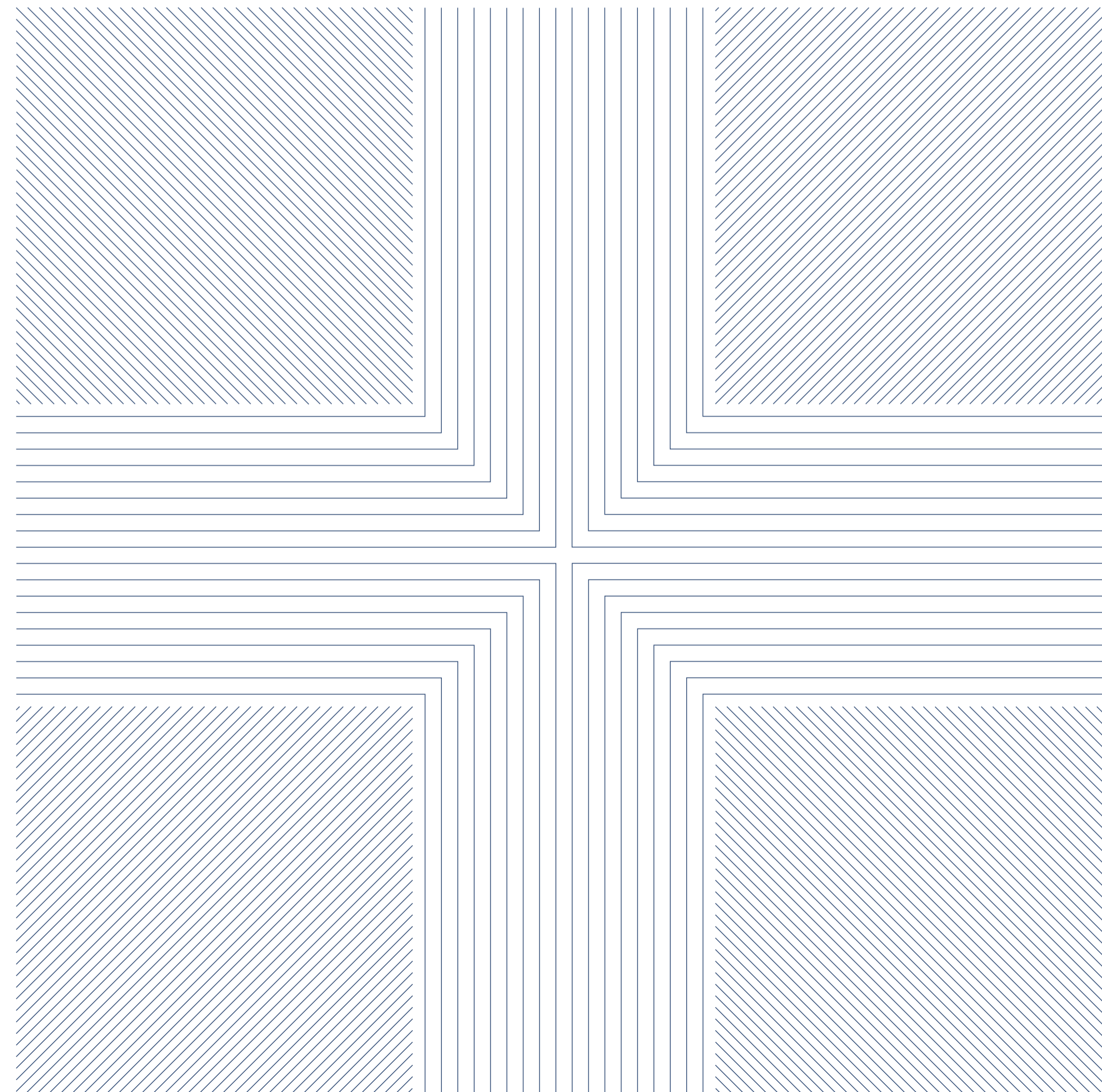

RESIDENCE
PH1

Exclusive Sales and Marketing by
Douglas Elliman Development Marketing

 Terra

This project is being developed by CG Summer Investments, LLP, a Florida limited liability partnership ("Developer"), which has a limited right to use the trademarked names and logos of Terra and Mr. C. Any and all statements, disclosures and/or representations shall be deemed made by Developer and not by Terra and/or Mr. C, and you agree to look solely to Developer (and not to Terra, Mr. C and/or any of their affiliates) with respect to any and all matters relating to the sales and marketing and/or development of the project. ORAL REPRESENTATIONS CANNOT BE RELIED UPON AS CORRECTLY STATING THE REPRESENTATIONS OF THE DEVELOPER. FOR CORRECT REPRESENTATIONS, MAKE REFERENCE TO THIS BROCHURE AND TO THE DOCUMENTS REQUIRED BY SECTION 718.503, FLORIDA STATUTES, TO BE FURNISHED BY A DEVELOPER TO A BUYER OR LESSEE. These materials are not intended to be an offer to sell, or solicitation to buy a unit in the condominium. Such an offering shall only be made pursuant to the prospectus (offering circular) for the condominium and no statements should be relied upon unless made in the prospectus or in the applicable purchase agreement. In no event shall any solicitation, offer or sale of a unit in the condominium be made in, or to residents of, any state or country in which such activity would be unlawful.

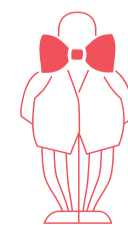

Mr. C
RESIDENCES
COCONUT GROVE, FL

BY
IGNAZIO
AND
MAGGIO
CIPRIANI

RESIDENCE
PH1

FEATURES
5 Bedrooms
4 Bathrooms
Powder Room

INDOOR AREA
3645 ft²
339 m²

OUTDOOR LIVING
985 ft²
92 m²

TOTAL AREA
4630 ft²
430 m²

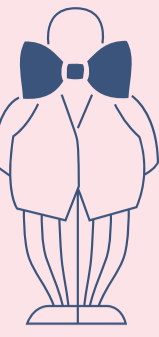

Exclusive Sales and Marketing by Douglas Elliman Development Marketing

Stated square footages and dimensions are measured to the exterior boundaries of the exterior walls and the centerline of interior demising walls and in fact vary from the square footage and dimensions that would be determined by using the description and definition of the "Unit" set forth in the Declaration (which generally only includes the interior airspace between the perimeter walls and excludes all interior structural components and other common elements). This method is generally used in sales materials and is provided to allow a prospective buyer to compare the Units with units in other condominium projects that utilize the same method. Measurements of rooms set forth on this floor plan are generally taken at the farthest points of each given room (as if the room were a perfect rectangle), without regard for any cutouts or variations. Accordingly, the area of the actual room will typically be smaller than the product obtained by multiplying the stated length and width. All dimensions are estimates which will vary with actual construction, and all floor plans, specifications and other development plans are subject to change and will not necessarily accurately reflect the final plans and specifications for the development.

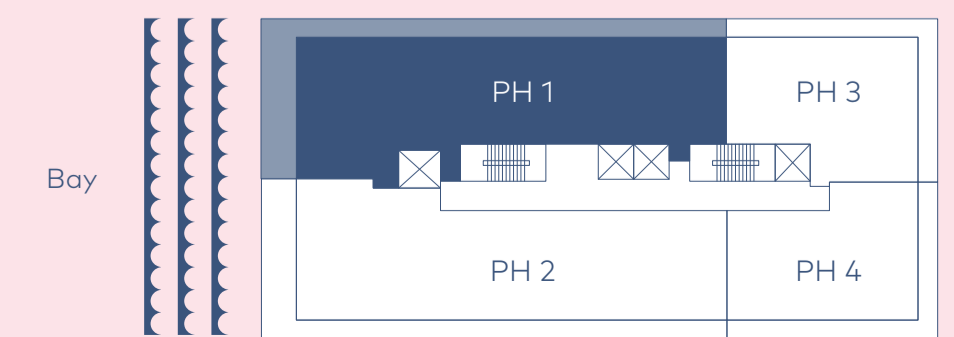
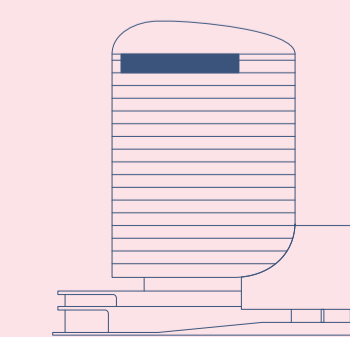



FEATURES & AMENITIES

DETAILS OF A LIFE WELL LIVED

Personalized services, including a 24-hour concierge, are complemented by a host of amenities at Mr. C Residences Coconut Grove.

Arrival Experience

- Covered Valet Drop-Off
- Reception and Concierge Desk
- Lobby Lounge
- Mail & Package Rooms
- Curated Art Pieces in Lobby
- Lush Landscaping

Dining & Retail

- Signature Café
- Specialty Gourmet Market
- Wellness Lounge and Juice Bar
- Private Bellini Bar on Pool Deck
- Poolside Food and Beverage Service
- In-Home Delivery from Café

Services

- Concierge Reception
- Butler Service
- Lifestyle and Nautical Concierge
- 24-Hour Doorman & Security
- 24-Hour Valet
- Mr. C Property Management Team
- Housekeeping Service Available

Residence Features

- Open Floor Plan Layouts
- 11-Foot Ceilings
- Floor-to-Ceiling Glass
- Bayshore, City and Grove Views
- Private Outdoor Terraces
- Italian Terrazzo & Quartz Countertops
- Italian Cabinetry
- European Porcelain Tile Floors
- Custom Kitchen Island

- Premium Appliances Subzero Wolf
- Solid Core Interior Wood Doors
- Pre-Wired for High-Speed Internet

Body & Mind Wellness Center

- Whole-Body Fitness Zones
- Stretch, Cardio, Weights & Fitness
- Personal Trainers & Specialty Classes Available
- Wellness Lounge w/Juice Bar
- Indoor Yoga Studio
- Peloton Studio
- Men's and Women's Locker Rooms
- Signature Spa with Treatment Rooms
- Steam & Sauna

Bayshore Owners' Club

- Bayshore Club Pool w/Sundeck
- Poolside Food & Beverage Service
- Cabanas w/Towel Service
- Pool Bar & Event Lounge
- Garden-Level Lap Pool
- Billiards Room
- Library & Screen Lounge
- Little C's Learning & Adventure Lab
- Teen Game Lounge
- Business Lounge w/Meeting Rooms

Mr. C Sales Gallery
2640 S. Bayshore Drive
Coconut Grove, FL 33133

MRCGrove.com

COME HOME TO MR. C

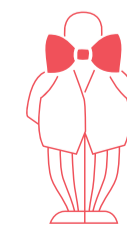

RESIDENCE
PH2

Exclusive Sales and Marketing by
Douglas Elliman Development Marketing

Terra

This project is being developed by CG Summer Investments, LLP, a Florida limited liability partnership ("Developer"), which has a limited right to use the trademarked names and logos of Terra and Mr. C. Any and all statements, disclosures and/or representations shall be deemed made by Developer and not by Terra and/or Mr. C, and you agree to look solely to Developer (and not to Terra, Mr. C and/or any of their affiliates) with respect to any and all matters relating to the sales and marketing and/or development of the project. ORAL REPRESENTATIONS CANNOT BE RELIED UPON AS CORRECTLY STATING THE REPRESENTATIONS OF THE DEVELOPER. FOR CORRECT REPRESENTATIONS, MAKE REFERENCE TO THIS BROCHURE AND TO THE DOCUMENTS REQUIRED BY SECTION 718.503, FLORIDA STATUTES, TO BE FURNISHED BY A DEVELOPER TO A BUYER OR LESSEE. These materials are not intended to be an offer to sell, or solicitation to buy a unit in the condominium. Such an offering shall only be made pursuant to the prospectus (offering circular) for the condominium and no statements should be relied upon unless made in the prospectus or in the applicable purchase agreement. In no event shall any solicitation, offer or sale of a unit in the condominium be made in, or to residents of, any state or country in which such activity would be unlawful.

Mr. C
RESIDENCES
COCONUT GROVE, FL

BY
IGNAZIO
AND
MAGGIO
CIPRIANI

RESIDENCE
PH2

FEATURES
5 Bedrooms
4 Bathrooms
Powder Room

INDOOR AREA
3590 ft²
334 m²

OUTDOOR LIVING
985 ft²
92 m²

TOTAL AREA
4575 ft²
425 m²



Exclusive Sales and Marketing by Douglas Elliman Development Marketing

Stated square footages and dimensions are measured to the exterior boundaries of the exterior walls and the centerline of interior demising walls and in fact vary from the square footage and dimensions that would be determined by using the description and definition of the "Unit" set forth in the Declaration (which generally only includes the interior airspace between the perimeter walls and excludes all interior structural components and other common elements). This method is generally used in sales materials and is provided to allow a prospective buyer to compare the Units with units in other condominium projects that utilize the same method. Measurements of rooms set forth on this floor plan are generally taken at the farthest points of each given room (as if the room were a perfect rectangle), without regard for any cutouts or variations. Accordingly, the area of the actual room will typically be smaller than the product obtained by multiplying the stated length and width. All dimensions are estimates which will vary with actual construction, and all floor plans, specifications and other development plans are subject to change and will not necessarily accurately reflect the final plans and specifications for the development.

